

# SERVICE MANUAL

N150RD / N151RD

*notebook*





**Notebook Computer**

**N150RD / N151RD**

**Service Manual**

### Notice

The company reserves the right to revise this publication or to change its contents without notice. Information contained herein is for reference only and does not constitute a commitment on the part of the manufacturer or any subsequent vendor. They assume no responsibility or liability for any errors or inaccuracies that may appear in this publication nor are they in anyway responsible for any loss or damage resulting from the use (or misuse) of this publication.

This publication and any accompanying software may not, in whole or in part, be reproduced, translated, transmitted or reduced to any machine readable form without prior consent from the vendor, manufacturer or creators of this publication, except for copies kept by the user for backup purposes.

Brand and product names mentioned in this publication may or may not be copyrights and/or registered trademarks of their respective companies. They are mentioned for identification purposes only and are not intended as an endorsement of that product or its manufacturer.

Version 1.0  
September 2015

### Trademarks

**Intel and Intel Core** are trademarks of Intel Corporation.

**Windows<sup>®</sup>** is a registered trademark of Microsoft Corporation.

Other brand and product names are trademarks and /or registered trademarks of their respective companies.





## About this Manual

This manual is intended for service personnel who have completed sufficient training to undertake the maintenance and inspection of personal computers.

It is organized to allow you to look up basic information for servicing and/or upgrading components of the *NI50RD* / *NI51RD* series notebook PC.

The following information is included:

Chapter 1, Introduction, provides general information about the location of system elements and their specifications.

Chapter 2, Disassembly, provides step-by-step instructions for disassembling parts and subsystems and how to upgrade elements of the system.

Appendix A, Part Lists

Appendix B, Schematic Diagrams

Appendix C, Updating the FLASH ROM BIOS

## IMPORTANT SAFETY INSTRUCTIONS

Follow basic safety precautions, including those listed below, to reduce the risk of fire, electric shock and injury to persons when using any electrical equipment:

1. Do not use this product near water, for example near a bath tub, wash bowl, kitchen sink or laundry tub, in a wet basement or near a swimming pool.
2. Avoid using a telephone (other than a cordless type) during an electrical storm. There may be a remote risk of electrical shock from lightning.
3. Do not use the telephone to report a gas leak in the vicinity of the leak.
4. Use only the power cord and batteries indicated in this manual. Do not dispose of batteries in a fire. They may explode. Check with local codes for possible special disposal instructions.
5. This product is intended to be supplied by a Listed Power Unit as follows:
  - AC Input of 100 - 240V, 50 - 60Hz, DC Output of 19.5V, 6.15A (**120** Watts) minimum AC/DC Adapter.

## CAUTION

**This Computer's Optical Device is a Laser Class 1 Product**

## FCC Statement

This device complies with Part 15 of the FCC Rules. Operation is subject to the following two conditions:

This device may not cause harmful interference.

This device must accept any interference received, including interference that may cause undesired operation.

## Instructions for Care and Operation

The notebook computer is quite rugged, but it can be damaged. To prevent this, follow these suggestions:

1. **Don't drop it, or expose it to shock.** If the computer falls, the case and the components could be damaged.



2. **Keep it dry, and don't overheat it.** Keep the computer and power supply away from any kind of heating element. This is an electrical appliance. If water or any other liquid gets into it, the computer could be badly damaged.

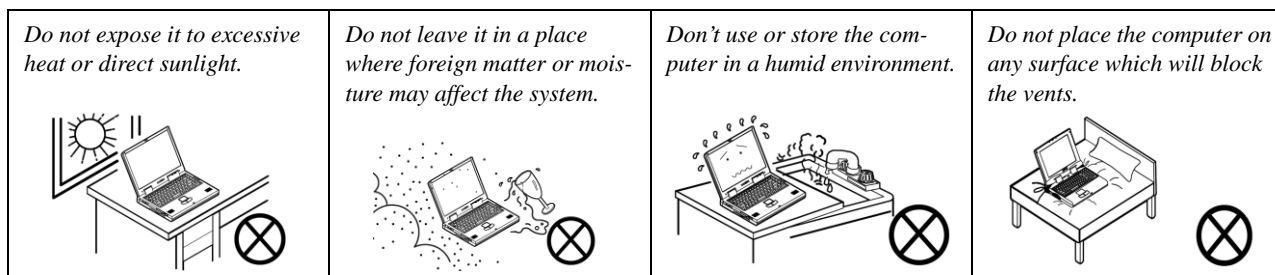

3. **Follow the proper working procedures for the computer.** Shut the computer down properly and don't forget to save your work. Remember to periodically save your data as data may be lost if the battery is depleted.

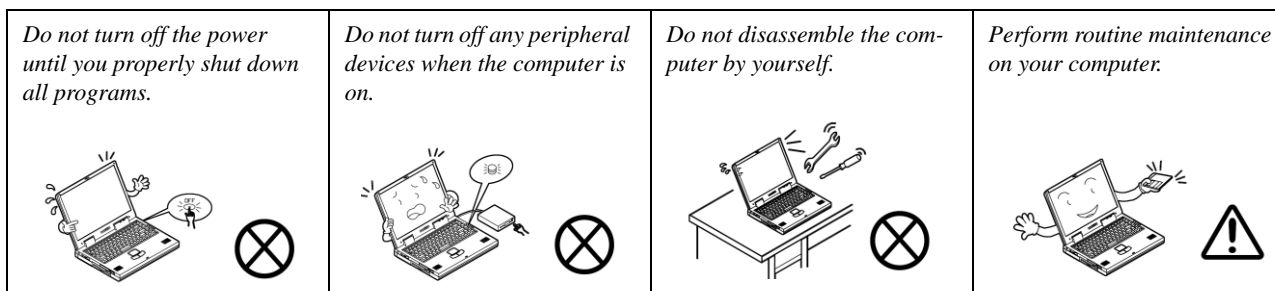

4. **Avoid interference.** Keep the computer away from high capacity transformers, electric motors, and other strong magnetic fields. These can hinder proper performance and damage your data.
5. **Take care when using peripheral devices.**

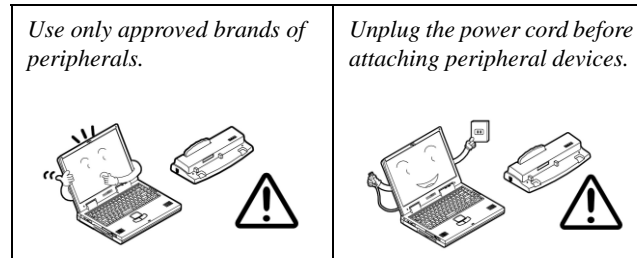

## Power Safety

The computer has specific power requirements:

- Only use a power adapter approved for use with this computer.
- Your AC adapter may be designed for international travel but it still requires a steady, uninterrupted power supply. If you are unsure of your local power specifications, consult your service representative or local power company.
- The power adapter may have either a 2-prong or a 3-prong grounded plug. The third prong is an important safety feature; do not defeat its purpose. If you do not have access to a compatible outlet, have a qualified electrician install one.
- When you want to unplug the power cord, be sure to disconnect it by the plug head, not by its wire.
- Make sure the socket and any extension cord(s) you use can support the total current load of all the connected devices.
- Before cleaning the computer, make sure it is disconnected from any external power supplies.

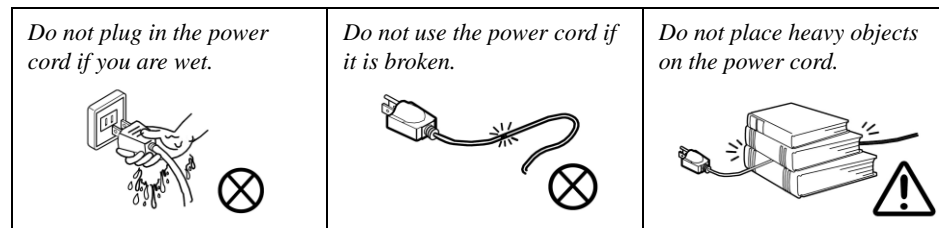

### Power Safety Warning

Before you undertake any upgrade procedures, make sure that you have turned off the power, and disconnected all peripherals and cables (including telephone lines and power cord). It is advisable to also remove your battery in order to prevent accidentally turning the machine on.

## Battery Precautions

- Only use batteries designed for this computer. The wrong battery type may explode, leak or damage the computer.
- Do not continue to use a battery that has been dropped, or that appears damaged (e.g. bent or twisted) in any way. Even if the computer continues to work with a damaged battery in place, it may cause circuit damage, which may possibly result in fire.
- Recharge the batteries using the notebook's system. Incorrect recharging may make the battery explode.
- Do not try to repair a battery pack. Refer any battery pack repair or replacement to your service representative or qualified service personnel.
- Keep children away from, and promptly dispose of a damaged battery. Always dispose of batteries carefully. Batteries may explode or leak if exposed to fire, or improperly handled or discarded.
- Keep the battery away from metal appliances.
- Affix tape to the battery contacts before disposing of the battery.
- Do not touch the battery contacts with your hands or metal objects.

## Battery Guidelines

The following can also apply to any backup batteries you may have.

- If you do not use the battery for an extended period, then remove the battery from the computer for storage.
- Before removing the battery for storage charge it to 60% - 70%.
- Check stored batteries at least every 3 months and charge them to 60% - 70%.



### Battery Disposal

The product that you have purchased contains a rechargeable battery. The battery is recyclable. At the end of its useful life, under various state and local laws, it may be illegal to dispose of this battery into the municipal waste stream. Check with your local solid waste officials for details in your area for recycling options or proper disposal.

### Caution

Danger of explosion if battery is incorrectly replaced. Replace only with the same or equivalent type recommended by the manufacturer. Discard used battery according to the manufacturer's instructions.

### Battery Level

Click the battery icon  in the taskbar to see the current battery level and charge status. A battery that drops below a level of 10% will not allow the computer to boot up. Make sure that any battery that drops below 10% is recharged within one week.

## Related Documents

You may also need to consult the following manual for additional information:

### User's Manual on CD/DVD

This describes the notebook PC's features and the procedures for operating the computer and its ROM-based setup program. It also describes the installation and operation of the utility programs provided with the notebook PC.

## System Startup

1. Remove all packing materials.
2. Place the computer on a stable surface.
3. Insert the battery and make sure it is locked in position.
4. Securely attach any peripherals you want to use with the computer (e.g. keyboard and mouse) to their ports.
5. Attach the AC/DC adapter to the DC-In jack at the rear of the computer, then plug the AC power cord into an outlet, and connect the AC power cord to the AC/DC adapter.
6. Use one hand to raise the lid/LCD to a comfortable viewing angle (do not exceed 135 degrees); use the other hand (as illustrated in Figure 1) to support the base of the computer (**Note: Never** lift the computer by the lid/LCD).
7. Press the power button to turn the computer "on".

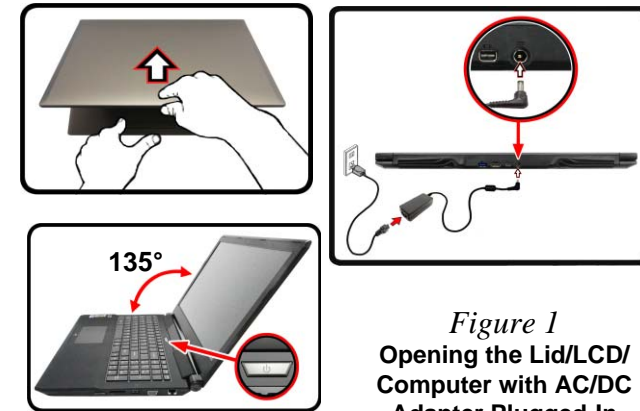

*Figure 1*  
**Opening the Lid/LCD/  
Computer with AC/DC  
Adapter Plugged-In**

### Shut Down

Note that you should always shut your computer down by choosing the **Shut down** command in **Windows** (see below). This will help prevent hard disk or system problems.

Click the icon  in the **Start Screen** and choose **Shut down** from the menu.



**Or**

Right-click the **Start button**  at the bottom of the **Start Screen** or the **Desktop** and choose **Shut down or sign out** > **Shut down** from the context menu.

## Contents

### Introduction .....1-1

Overview .....	1-1
Specifications .....	1-2
External Locator - Top View with LCD Panel Open .....	1-4
External Locator - Front & Right Side Views .....	1-5
External Locator - Left Side & Rear View .....	1-6
External Locator - Bottom View .....	1-7
Mainboard Overview - Top (Key Parts) .....	1-8
Mainboard Overview - Bottom (Key Parts) .....	1-9
Mainboard Overview - Top (Connectors) .....	1-10
Mainboard Overview - Bottom (Connectors) .....	1-11

### Disassembly .....2-1

Overview .....	2-1
Maintenance Tools .....	2-2
Connections .....	2-2
Maintenance Precautions .....	2-3
Disassembly Steps .....	2-4
Removing the Battery .....	2-5
Removing the Hard Disk Drive .....	2-6
Removing the Optical (CD/DVD) Device .....	2-10
Removing the Keyboard .....	2-11
Removing the System Memory (RAM) .....	2-12
Removing the M.2 SSD Module .....	2-13
Removing the Wireless LAN Module .....	2-14
Wireless LAN, Combo, 3G & LTE Module Cables .....	2-15
Removing the 3G/4G Module .....	2-16

### Part Lists .....A-1

Part List Illustration Location .....	A-2
Top .....	A-3

Bottom .....	A-4
Main Board .....	A-5
HDD .....	A-6
2nd HDD .....	A-7
LCD .....	A-8
DVD .....	A-9
Dummy ODD .....	A-10

### Schematic Diagrams.....B-1

System Block Diagram .....	B-2
Processor 1/7 .....	B-3
Processor 2/7 .....	B-4
Processor 3/7 .....	B-5
Processor 4/7 .....	B-6
Processor 5/7 .....	B-7
Processor 6/7 .....	B-8
Processor 7/7 .....	B-9
DDR3 SO-DIMM A_0 .....	B-10
DDR3 SO-DIMM B_0 .....	B-11
PS8625 .....	B-12
Panel, BKL Control .....	B-13
RTD2168 .....	B-14
MIni DP Port .....	B-15
VGA Frame Buffer Interface .....	B-16
VGA Frame Buffer A .....	B-17
VGA Frame Buffer A .....	B-18
VGA PCI-E Interface .....	B-19
VGA Frame Buffer B .....	B-20
VGA Frame Buffer B .....	B-21
VGA I/O .....	B-22
VGA NVVDD Decoupling .....	B-23

## Preface

---

PCH 1/9 .....	B-24	Front LED Board .....	B-56
PCH 2/9 .....	B-25	Click / Finger Con Board .....	B-57
PCH 3/9 .....	B-26	Fingerprint Board .....	B-58
PCH 4/9 .....	B-27	N150 LID, PWR SW Board .....	B-59
PCH 5/9 .....	B-28	N170 LID, PWR SW Board .....	B-60
PCH 6/9 .....	B-29	N170 ODD Ext. Board .....	B-61
PCH 7/9 .....	B-30	Power Sequence .....	B-62
PCH 8/9 .....	B-31	Option BOM .....	B-63
PCH 9/9 .....	B-32	<b>Updating the FLASH ROM BIOS..... C-1</b>	
WLAN, 4G, Fan, Audio Con .....	B-33	Download the BIOS .....	C-1
CCD, M-Key, Click Conn .....	B-34	Unzip the downloaded files to a bootable CD/DVD or	
USB 3.0, USB Charger .....	B-35	USB Flash drive .....	C-1
LAN RTL8411B, Card Reader .....	B-36	Set the computer to boot from the external drive .....	C-1
HDMI, PS8407A .....	B-37	Use the flash tools to update the BIOS .....	C-2
Audio Codec ALC269 .....	B-38	Restart the computer (booting from the HDD) .....	C-2
HDD, TPM, KB LED, PWR Con, T/P .....	B-39		
KBC-ITE IT8587 .....	B-40		
System Power .....	B-41		
VDD3, VDD5 .....	B-42		
DRAM Power .....	B-43		
Power 1.0V, VCCIO .....	B-44		
1.0DX_VCCSTG/VCCSFR_OC .....	B-45		
VCore, VCCSA .....	B-46		
VCore & VCCSA Output Stage .....	B-47		
VCCGT .....	B-48		
VCCGT Output Stage .....	B-49		
NVVDD .....	B-50		
3V3_AON, 3V3_RUN, PEX_VDD .....	B-51		
FBVDDQ .....	B-52		
AC-In, Charger .....	B-53		
N155, N157 KB LED, PWR Board .....	B-54		
Audio Board .....	B-55		



# Chapter 1: Introduction

## Overview

This manual covers the information you need to service or upgrade the *N150RD / N151RD* series notebook computer. Information about operating the computer (e.g. getting started, and the *Setup* utility) is in the *User's Manual*. Information about drivers (e.g. VGA & audio) is also found in the *User's Manual*. The manual is shipped with the computer.

Operating systems (e.g. *Windows 8.1*, etc.) have their own manuals as do application softwares (e.g. word processing and database programs). If you have questions about those programs, you should consult those manuals.

The *N150RD / N151RD* series notebook is designed to be upgradeable. See [Disassembly on page 2 - 1](#) for a detailed description of the upgrade procedures for each specific component. Please take note of the warning and safety information indicated by the “” symbol.

The balance of this chapter reviews the computer's technical specifications and features.

## Specifications



### Latest Specification Information

The specifications listed here are correct at the time of sending them to the press. Certain items (particularly processor types/speeds) may be changed, delayed or updated due to the manufacturer's release schedule. Check with your service center for more details.



### CPU

The CPU is not a user serviceable part. Accessing the CPU in any way may violate your warranty.

### Processor Options

#### Intel® Core™ i7 Processor

**i7-6700HQ (2.60GHz)**

8MB Smart Cache, 14nm, DDR3L-1600MHz, TDP 45W

#### Intel® Core™ i5 Processor

**i5-6300HQ (2.30GHz)**

6MB Smart Cache, 14nm, DDR3L-1600MHz, TDP 45W

### Core Logic

Intel® HM170 Chipset

### BIOS

64Mb SPI Flash ROM

AMI BIOS

### Memory

Two 204 Pin SO-DIMM Sockets Supporting **DDR3L**

**1600MHz** Memory

Memory Expandable up to 16GB

(The real memory operating frequency depends on the FSB of the processor.)

### LCD Options

15.6" (39.62cm), 16:9, QFHD (3840x2160)/FHD (1920x1080)

### Video Adapter

#### Intel® Integrated GPU and NVIDIA® Discrete GPU

Supports Microsoft Hybrid Graphics

#### Intel Integrated GPU

**Intel® HD Graphics 530**

Dynamic Frequency

Intel Dynamic Video Memory Technology

Microsoft DirectX®12 Compatible

#### NVIDIA® Discrete GPU

**NVIDIA® GeForce GTX 960M**

**2GB** GDDR5 Video RAM on board

Microsoft DirectX® 12 Compatibl

### Storage

One Changeable 2.5" 9.5mm/7.0mm (h) SATA HDD/SSD

**(Factory Option)** One 9.5mm(h) Optical Device Type Drive (Super Multi Drive)

**(Factory Option)** 2.5" 7.0mm 2nd HDD/SSD caddy

**(Factory Option)** One M.2 **SATA/PCIe Gen3 x4** Solid State Drive (SSD)

### Audio

High Definition Audio Compliant Interface

2 \* Built-In Speakers

ANSP™ 3D sound technology on headphone output

Built-In Array Microphone

Sound Blaster™ Cinema 2

### Security

Security (Kensington® Type) Lock Slot

BIOS Password

**(Factory Option)** Fingerprint Reader

Intel PTT

**Keyboard**

Full-size Winkey **Illuminated White-LED** Keyboard (with numeric keypad)

**Pointing Device**

Built-in Touchpad

**Interface**

Four USB 3.0 Ports

One Mini DisplayPort (1.2)

One HDMI-Out Port

One External Monitor Port

One Headphone-Out Jack

One Microphone-In Jack

One S/PDIF Out Jack

One RJ-45 LAN Jack

One DC-in Jack

**M.2 Slots**

Slot 1 for **Combo WLAN and Bluetooth**

Slot 2 for **SATA/PCIe Gen3 x4 SSD**

**(Factory Option)** Slot 3 for **3G/4G** Module

**Card Reader**

Embedded Multi-In-1 Card Reader

MMC (MultiMedia Card) / RS MMC

SD (Secure Digital) / Mini SD / SDHC/ SDXC

**Communication**

Built-In Gigabit Ethernet LAN

2.0M FHD PC Camera Module

**(Factory Option)** M.2 **3G** or **4G** Module

**WLAN/ Bluetooth M.2 Modules:**

**(Factory Option)** Intel® Wireless-AC 8260 Wireless LAN **(802.11ac)** + Bluetooth **4.1**

**(Factory Option)** Intel® Wireless-AC 7265 Wireless LAN **(802.11ac)** + Bluetooth **4.0**

**(Factory Option)** Intel® Wireless-AC 3165 Wireless LAN **(802.11ac)** + Bluetooth **4.0**

**(Factory Option)** Intel® Wireless-N 7265 Wireless LAN **(802.11b/g/n)** + Bluetooth **4.0**

**(Factory Option)** Qualcomm® Atheros Killer™ Wireless-AC 1535 Wireless LAN **(802.11ac)** + Bluetooth **4.1**

**(Factory Option)** Third-Party Wireless LAN **(802.11b/g/n)** + Bluetooth **4.0**

**Environmental Spec****Temperature**

Operating: 5°C - 35°C

Non-Operating: -20°C - 60°C

**Relative Humidity**

Operating: 20% - 80%

Non-Operating: 10% - 90%

**Power**

Full Range AC/DC Adapter

AC Input: 100 - 240V, 50 - 60Hz

DC Output: 19.5V, 6.15A (**120W**)

Built-in 6 Cell Smart Lithium-Ion Battery Pack, 62WH

**Dimensions & Weight**

385mm (w) \* 268mm (d) \* 28.5mm (h)

**2.5kg** (Barebone with 62WH Battery)

## Introduction

*Figure 1*  
**Top View**

1. PC Camera
2. \*PC Camera LED  
*\*When the PC camera is in use, the LED will be illuminated.*
3. Microphone
4. LCD
5. Speakers
6. Power Button
7. Keyboard
8. Touchpad & Buttons
9. Fingerprint Reader (Optional)

## External Locator - Top View with LCD Panel Open



## External Locator - Front & Right Side Views

FRONT VIEW



*Figure 2*  
**Front View**  
1. LED Indicators

RIGHT SIDE VIEW



*Figure 3*  
**Right Side View**  
1. USIM Card Reader (for 3G/4G USIM Cards)  
2. Multi-in-1 Card Reader  
3. USB 3.0 Port  
4. External Monitor Port  
5. RJ-45 LAN Jack

## Introduction

### External Locator - Left Side & Rear View

*Figure 4*  
**Left Side View**

1. Security Lock Slot
2. USB 3.0 Ports
3. S/PDIF-Out Jack
4. Microphone-In Jack
5. Headphone-Out Jack
6. Optical Device Drive Bay
7. Emergency Eject Hole

LEFT SIDE VIEW



*Figure 5*  
**Rear View**

1. Vent
2. USB 3.0 Port
3. HDMI-Out Port
4. Mini Display Port
5. DC-In Jack

REAR VIEW



## External Locator - Bottom View

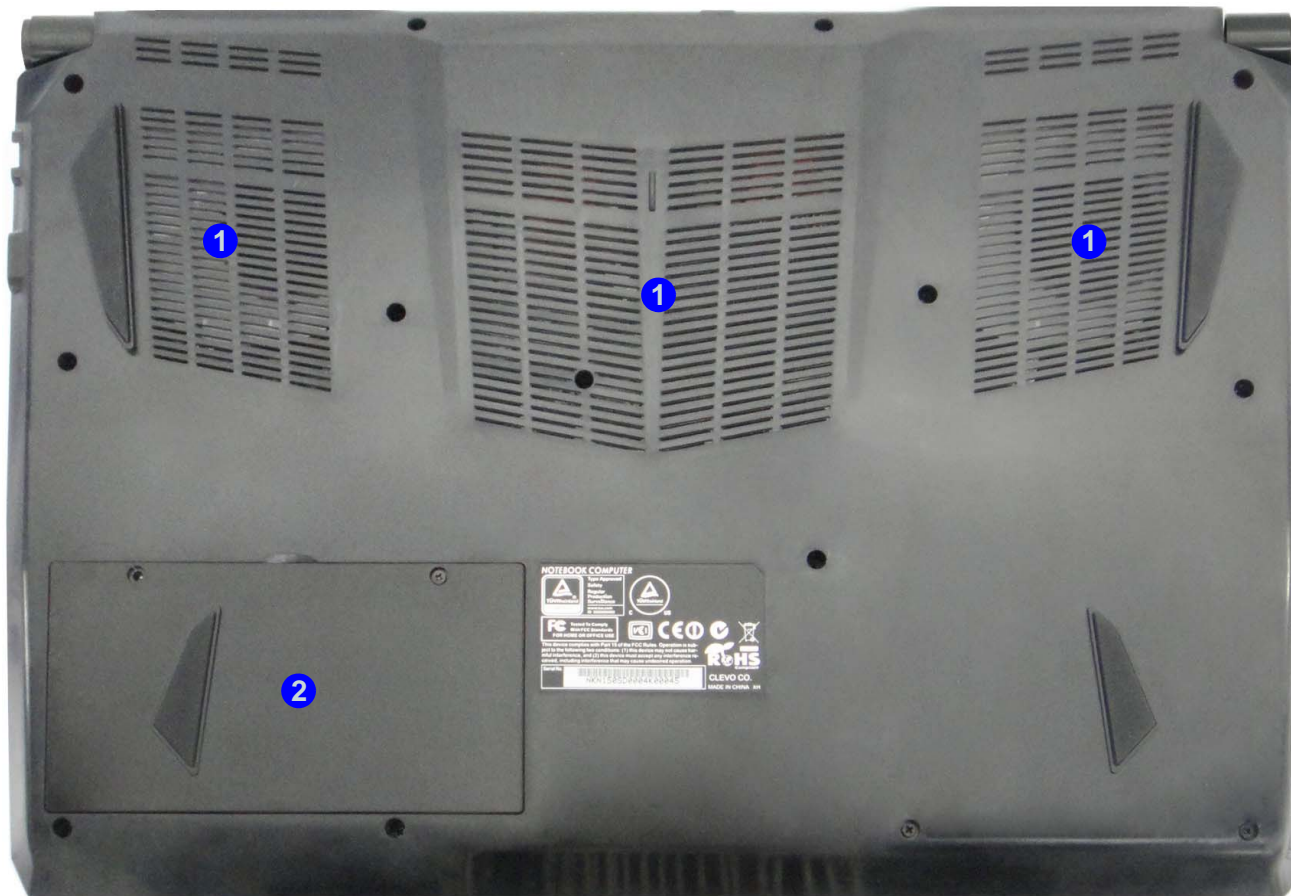

*Figure 6*  
**Bottom View**

1. Vent
2. Battery



### Overheating

To prevent your computer from overheating, make sure nothing blocks any vent while the computer is in use.



## Introduction

*Figure 7*  
Mainboard Top  
Key Parts

## Mainboard Overview - Top (Key Parts)

1. KBC-ITE IT8587

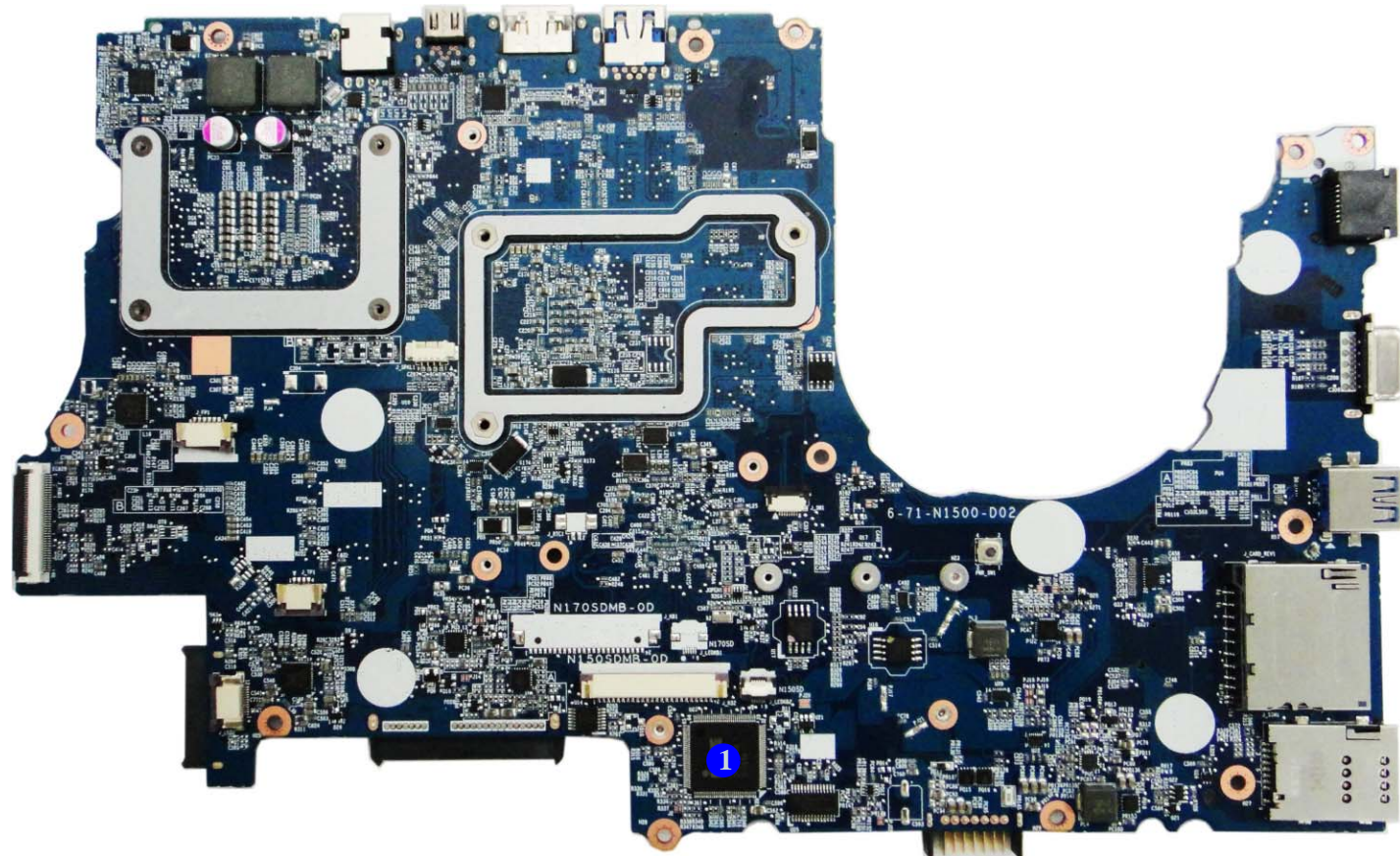



## Mainboard Overview - Bottom (Key Parts)

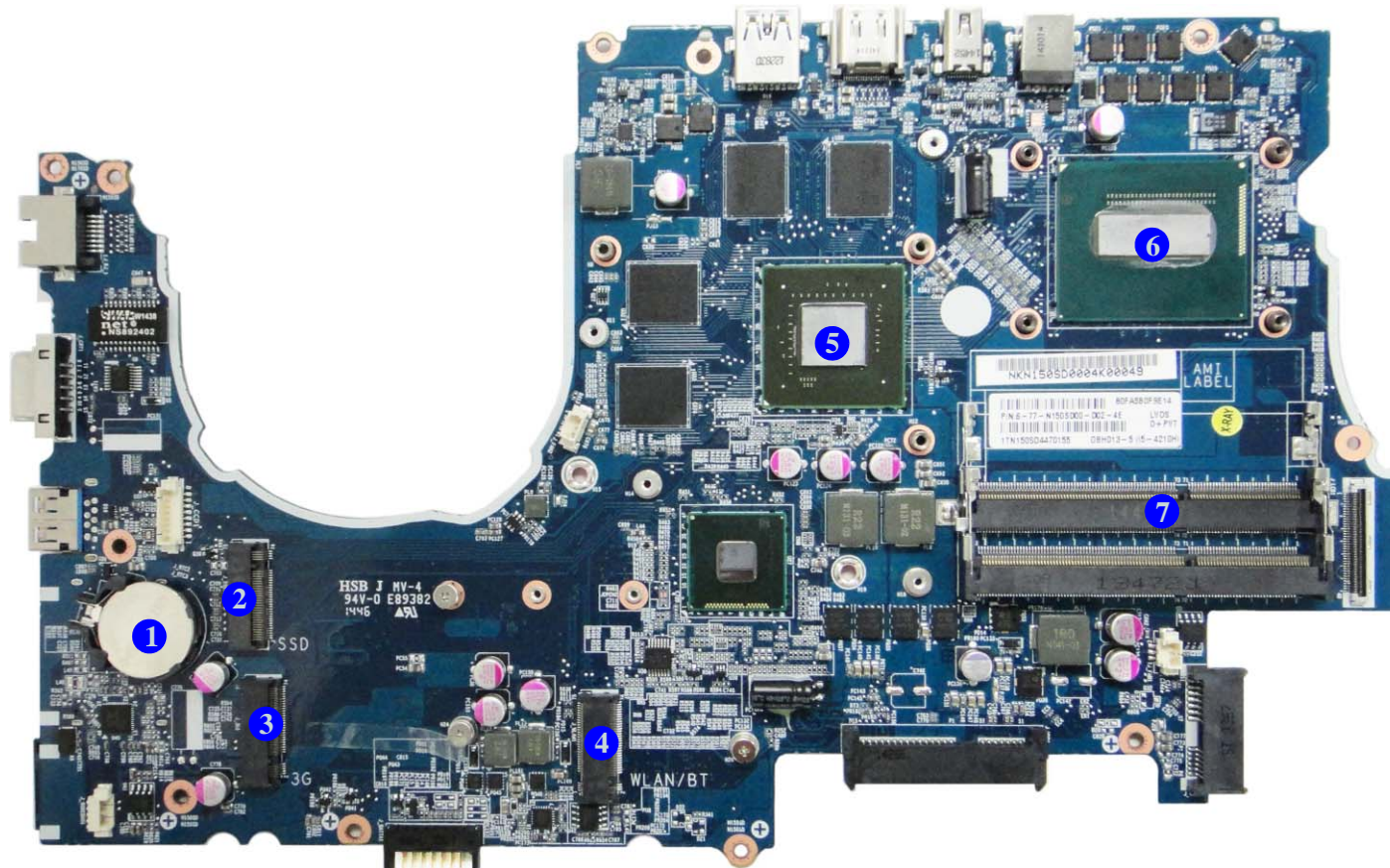

*Figure 8*  
**Mainboard Bottom  
Key Parts**

1. CMOS Battery
2. Mini-Card Connector (M.2 PCIE/SATA SSD Module)
3. Mini-Card Connector (M.2 3G/SATA Module)
4. Mini-Card Connector (WLAN Module)
5. GPU-GTX960M
6. CPU
7. Memory Slots (DDR3L SO-DIMM)

## Introduction

*Figure 9*  
**Mainboard Top  
Connectors**

## Mainboard Overview - Top (Connectors)

1. DC-In Jack
2. Mini Display Port
3. HDMI-Out Port
4. USB Port 3.0 Connector
5. Audio Board Connector
6. Finger Print Connector
7. TP Connector
8. LED Board Connector
9. HDD Connector
10. Keyboard Cable Connector
11. USIM Card Reader
12. Multi-in-1 Card Reader
13. USB Port 3.0 Connector
14. External Monitor Port
15. RJ-45 LAN Jack
16. Power Switch Board Connector
17. Speaker Connector

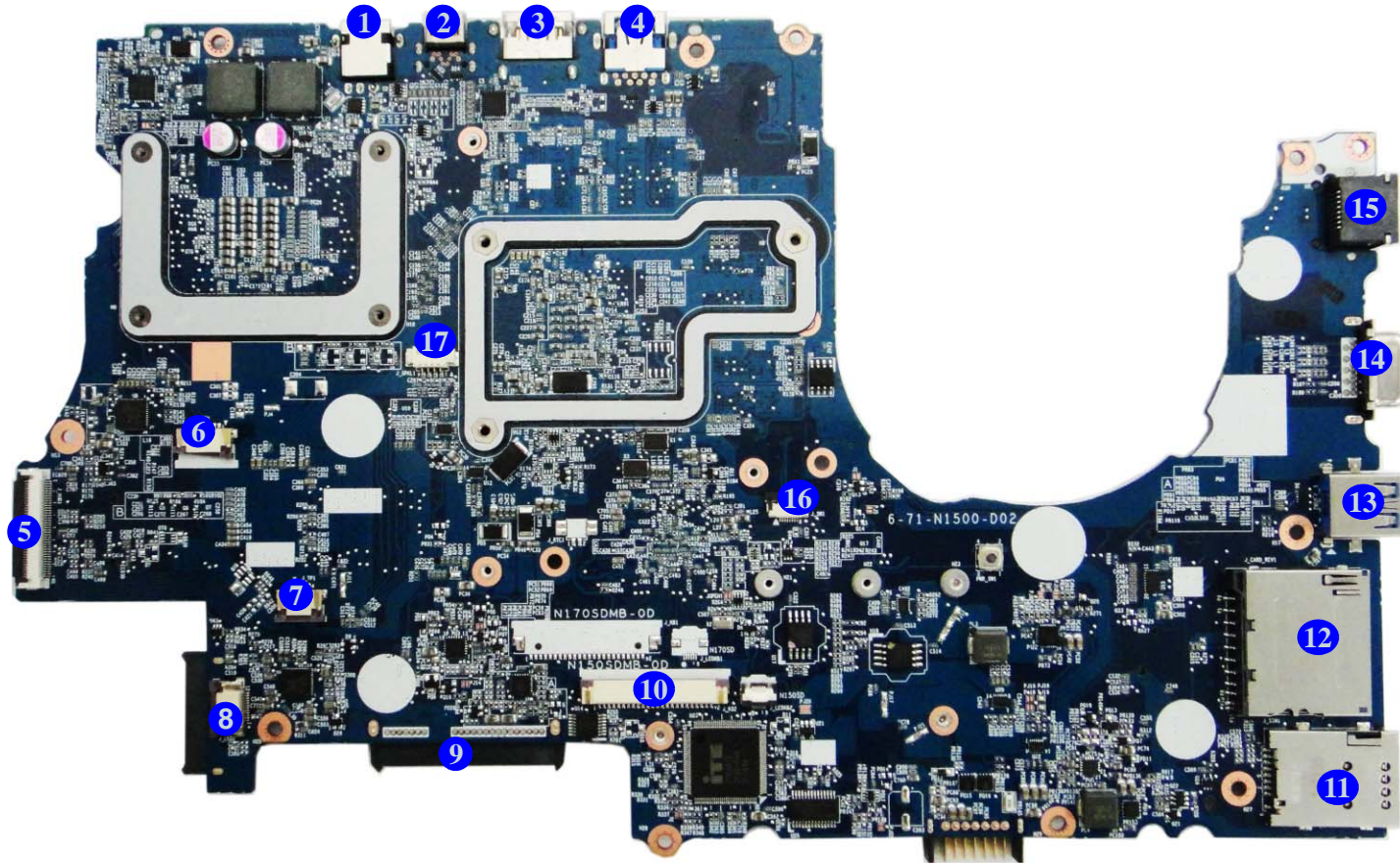



## Mainboard Overview - Bottom (Connectors)

*Figure 10*  
**Mainboard Bottom  
Connectors**

1. CCD Connector
2. Battery Connector
3. Fan Connector

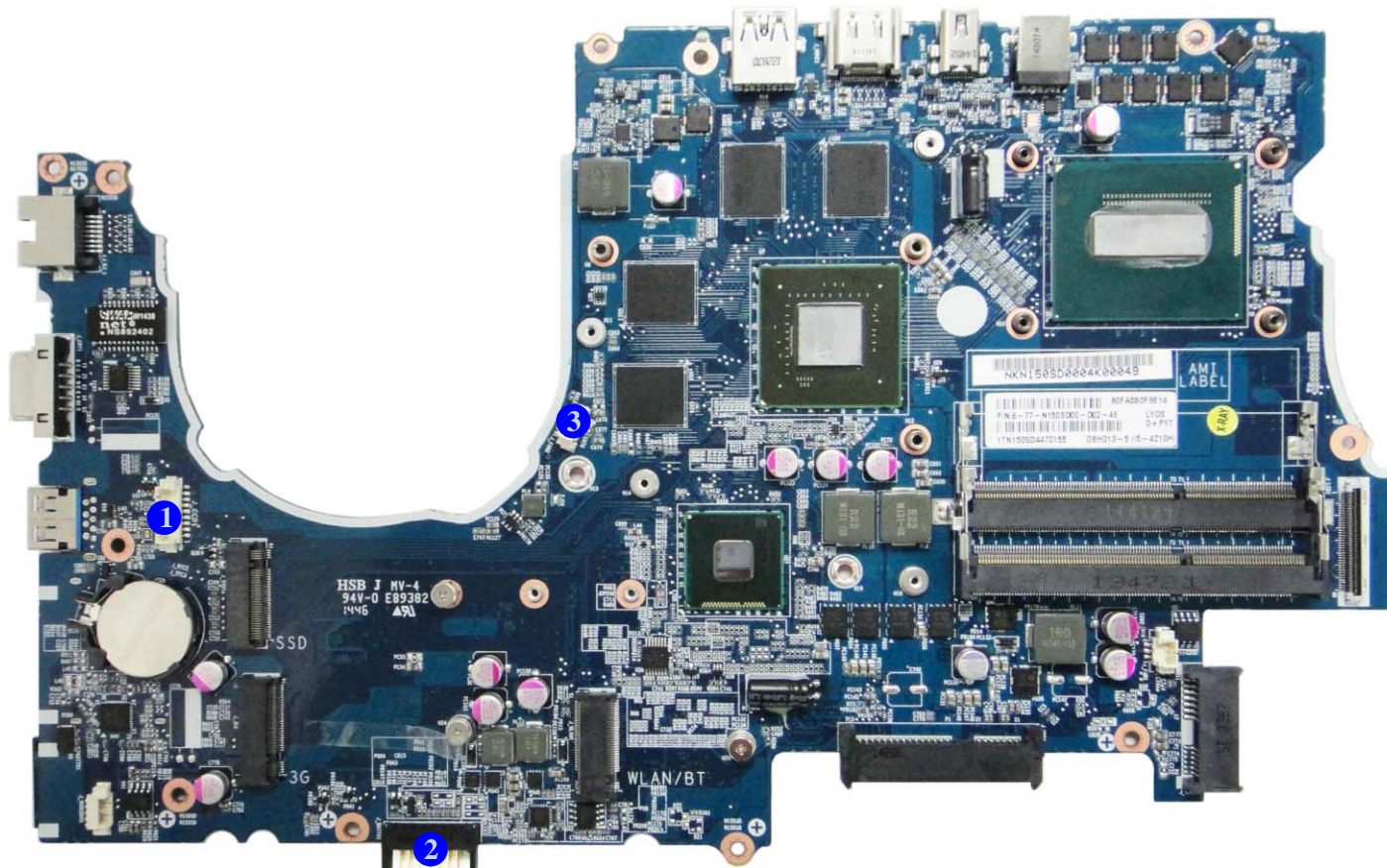



# Chapter 2: Disassembly

## Overview

This chapter provides step-by-step instructions for disassembling the *N150RD* / *N151RD* series notebook's parts and subsystems. When it comes to reassembly, reverse the procedures (unless otherwise indicated).

We suggest you completely review any procedure before you take the computer apart.

Procedures such as upgrading/replacing the RAM, optical device and hard disk are included in the User's Manual but are repeated here for your convenience.

To make the disassembly process easier each section may have a box in the page margin. Information contained under the figure # will give a synopsis of the sequence of procedures involved in the disassembly procedure. A box with a  lists the relevant parts you will have after the disassembly process is complete. **Note:** The parts listed will be for the disassembly procedure listed ONLY, and not any previous disassembly step(s) required. Refer to the part list for the previous disassembly procedure. The amount of screws you should be left with will be listed here also.

A box with a  will also provide any possible helpful information. A box with a  contains warnings.

An example of these types of boxes are shown in the sidebar.

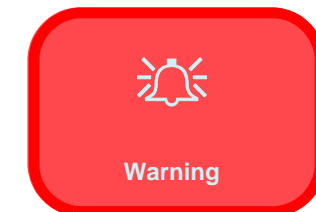
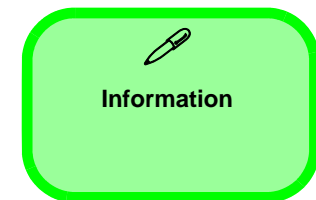

## Disassembly

---

**NOTE:** All disassembly procedures assume that the system is turned **OFF**, and disconnected from any power supply (the battery is removed too).

### Maintenance Tools

The following tools are recommended when working on the notebook PC:

- M3 Philips-head screwdriver
- M2.5 Philips-head screwdriver (magnetized)
- M2 Philips-head screwdriver
- Small flat-head screwdriver
- Pair of needle-nose pliers
- Anti-static wrist-strap

### Connections

Connections within the computer are one of four types:

Locking collar sockets for ribbon connectors	To release these connectors, use a small flat-head screwdriver to gently pry the locking collar away from its base. When replacing the connection, make sure the connector is oriented in the same way. The pin1 side is usually not indicated.
Pressure sockets for multi-wire connectors	To release this connector type, grasp it at its head and gently rock it from side to side as you pull it out. Do not pull on the wires themselves. When replacing the connection, do not try to force it. The socket only fits one way.
Pressure sockets for ribbon connectors	To release these connectors, use a small pair of needle-nose pliers to gently lift the connector away from its socket. When replacing the connection, make sure the connector is oriented in the same way. The pin1 side is usually not indicated.
Board-to-board or multi-pin sockets	To separate the boards, gently rock them from side to side as you pull them apart. If the connection is very tight, use a small flat-head screwdriver - use just enough force to start.

## Maintenance Precautions

The following precautions are a reminder. To avoid personal injury or damage to the computer while performing a removal and/or replacement job, take the following precautions:

1. **Don't drop it.** Perform your repairs and/or upgrades on a stable surface. If the computer falls, the case and other components could be damaged.
2. **Don't overheat it.** Note the proximity of any heating elements. Keep the computer out of direct sunlight.
3. **Avoid interference.** Note the proximity of any high capacity transformers, electric motors, and other strong magnetic fields. These can hinder proper performance and damage components and/or data. You should also monitor the position of magnetized tools (i.e. screwdrivers).
4. **Keep it dry.** This is an electrical appliance. If water or any other liquid gets into it, the computer could be badly damaged.
5. **Be careful with power.** Avoid accidental shocks, discharges or explosions.
  - Before removing or servicing any part from the computer, turn the computer off and detach any power supplies.
  - When you want to unplug the power cord or any cable/wire, be sure to disconnect it by the plug head. Do not pull on the wire.
6. **Peripherals** – Turn off and detach any peripherals.
7. **Beware of static discharge.** ICs, such as the CPU and main support chips, are vulnerable to static electricity. Before handling any part in the computer, discharge any static electricity inside the computer. When handling a printed circuit board, do not use gloves or other materials which allow static electricity buildup. We suggest that you use an anti-static wrist strap instead.
8. **Beware of corrosion.** As you perform your job, avoid touching any connector leads. Even the cleanest hands produce oils which can attract corrosive elements.
9. **Keep your work environment clean.** Tobacco smoke, dust or other air-borne particulate matter is often attracted to charged surfaces, reducing performance.
10. **Keep track of the components.** When removing or replacing any part, be careful not to leave small parts, such as screws, loose inside the computer.

## Cleaning

Do not apply cleaner directly to the computer, use a soft clean cloth.

Do not use volatile (petroleum distillates) or abrasive cleaners on any part of the computer.



### Power Safety Warning

Before you undertake any upgrade procedures, make sure that you have turned off the power, and disconnected all peripherals and cables (including telephone lines and power cord). It is advisable to also remove your battery in order to prevent accidentally turning the machine on.

### Disassembly Steps

The following table lists the disassembly steps, and on which page to find the related information. **PLEASE PERFORM THE DISASSEMBLY STEPS IN THE ORDER INDICATED.**

#### To remove the Battery:

1. Remove the battery *page 2 - 5*

#### To remove the HDD:

1. Remove the battery *page 2 - 5*
2. Remove the HDD *page 2 - 6*

#### To remove the Optical Device:

1. Remove the battery *page 2 - 5*
2. Remove the Optical device *page 2 - 10*

#### To remove the Keyboard:

1. Remove the battery *page 2 - 5*
2. Remove the keyboard *page 2 - 11*

#### To remove the System Memory:

1. Remove the battery *page 2 - 5*
2. Remove the system memory *page 2 - 12*

#### To remove the M.2 SSD:

1. Remove the battery *page 2 - 5*
2. Remove the SSD *page 2 - 13*

#### To remove the Wireless LAN Module:

1. Remove the battery *page 2 - 5*
2. Remove the WLAN *page 2 - 14*

#### To remove the 3G Module:

1. Remove the battery *page 2 - 5*
2. Remove the 3G *page 2 - 16*



## Removing the Battery

1. Turn the computer **off**, and turn it over.
2. Locate the battery and remove screws **1** - **2** (*Figure 1a*).
3. Carefully lift the battery **3** up in the direction of the arrow **4** (*Figure 1b*).
4. Remove the battery off the computer (*Figure 1c*).

*Figure 1*  
**Battery Removal**

- a. Remove the screws.
- b. Lift the battery.
- c. Remove the battery.

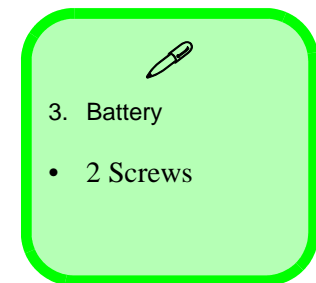
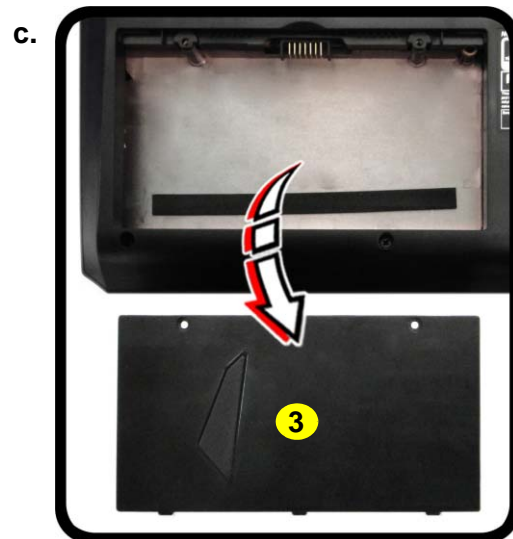
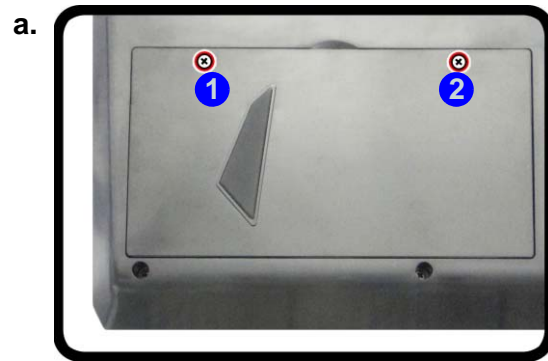

Figure 2  
HDD Assembly  
Removal

- a. Remove the SD cover and screws.
- b. Remove the bottom case.
- c. Locate the HDD.

## Removing the Hard Disk Drive

The hard disk drive can be taken out to accommodate other 2.5" serial (SATA) hard disk drives with a height of 9.5mm or 7mm (h). Follow your operating system's installation instructions, and install all necessary drivers and utilities (as outlined in **Chapter 4 of the User's Manual**) when setting up a new hard disk.

### Hard Disk Disassembly Process

1. Turn **off** the computer, remove the battery ([page 2 - 5](#)) and keyboard ([page 2 - 11](#)).
2. Remove the SD card cover **1** and screws **2 - 15** ([Figure 2a](#)).
3. Carefully lift the bottom case **16** up at point **17** and slide in the direction of the arrow **18** to remove it ([Figure 1b](#)).
4. The HDD will be visible at point **19** on the mainboard ([Figure 2a](#)).

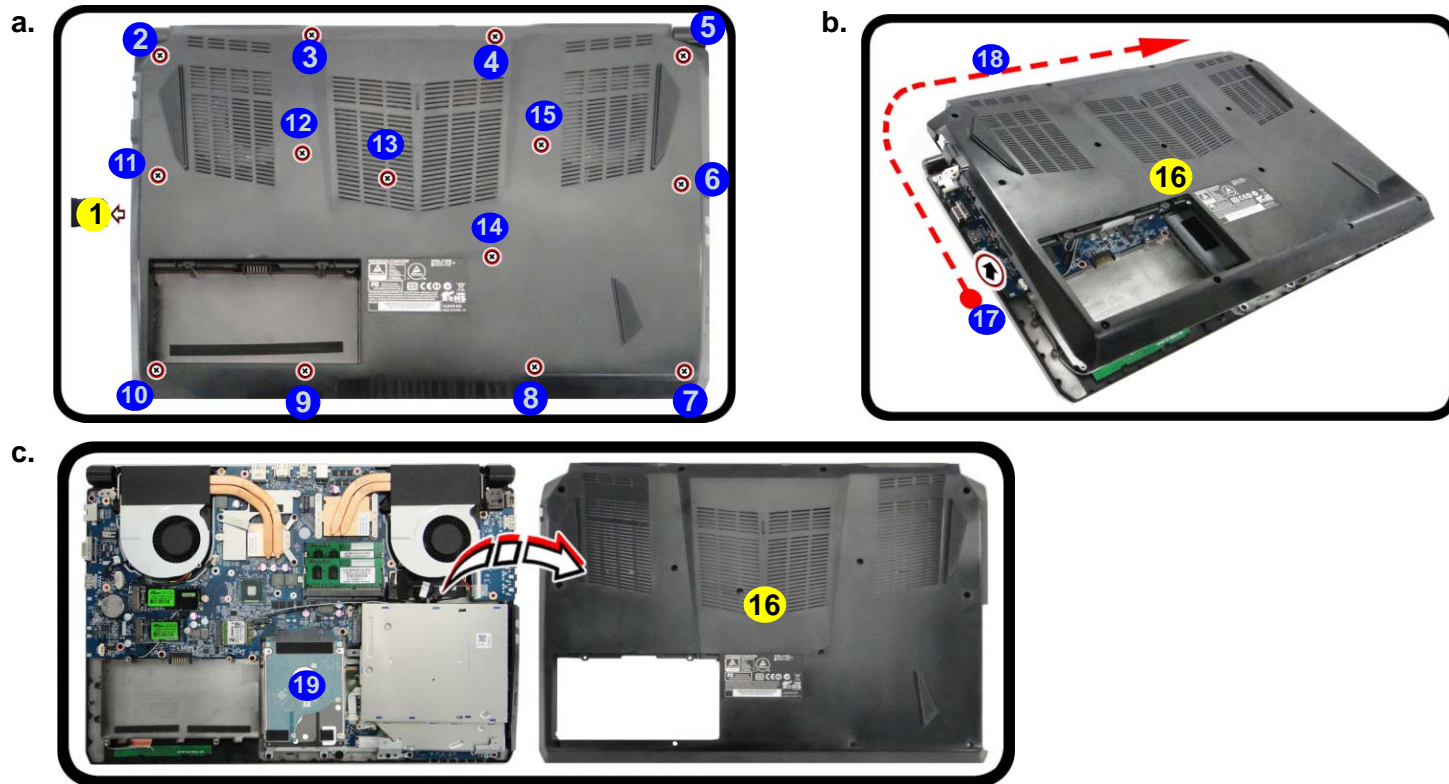



- 1. SD Card Cover
- 16. Bottom Case
- 14 Screws

- Remove screws 20 - 21 from the HDD assembly (Figure 3c).
- Lift the hard disk at a 45 degrees angle and slide it out in the direction of arrow 22 (Figure 4d).
- Remove the hard disk assembly 23 out of the bay 24 (Figure 4e).

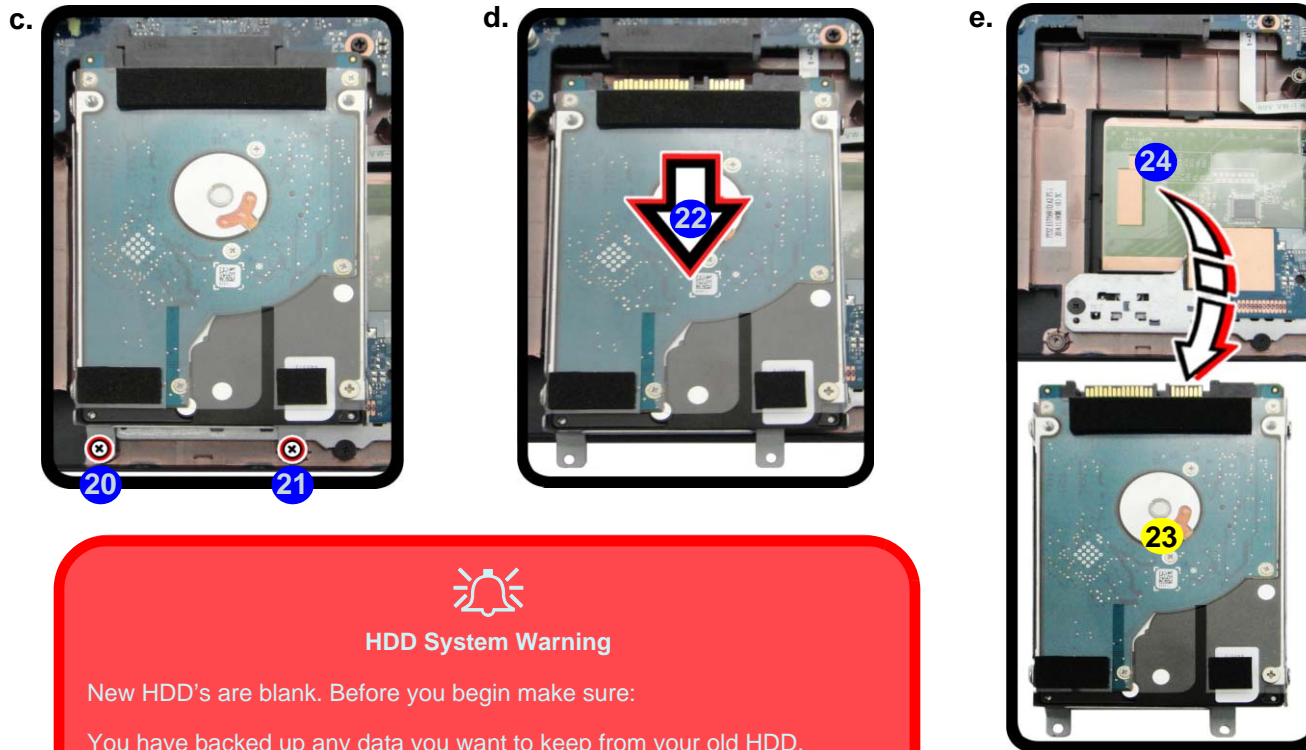

Figure 3  
HDD Assembly  
Removal (cont'd.)

- Remove the screws.
- Slide the HDD in the direction of the arrow.
- Lift the HDD assembly out of the bay.



### HDD System Warning

New HDD's are blank. Before you begin make sure:

You have backed up any data you want to keep from your old HDD.

You have all the CD-ROMs and FDDs required to install your operating system and programs.

If you have access to the internet, download the latest application and hardware driver updates for the operating system you plan to install. Copy these to a removable medium.



23. HDD Assembly

- 2 Screws

## Disassembly

*Figure 4*  
**HDD Assembly**  
**Removal (cont'd.)**

- f. Remove the screws from the HDD assembly.  
 g. Separate the HDD, mylar cover and bracket.

8. Remove screws 25 - 29 from the hard disk assembly (*Figure 4f*).  
 9. Separate the hard disk 30 from the bracket 31 and mylar cover 32 (*Figure 4g*).  
 10. Reverse the process to install a new hard disk (do not forget to insert the mylar cover between the bracket and hard disk as shown before replacing the screws).

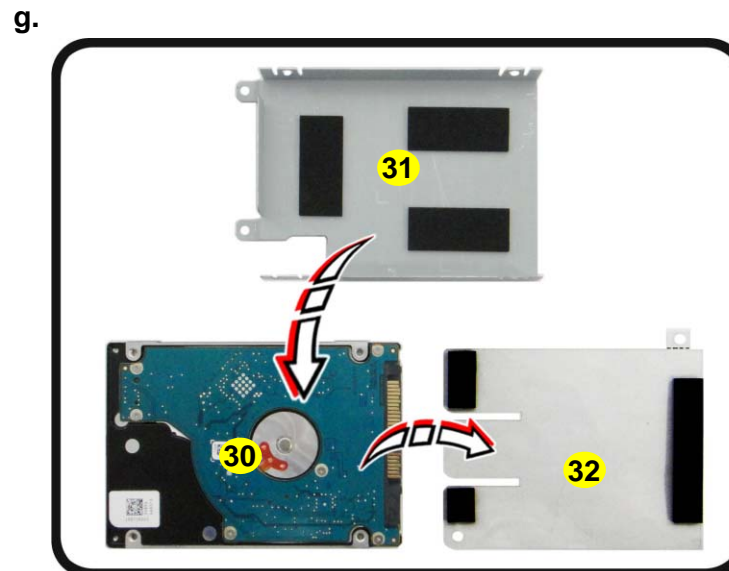
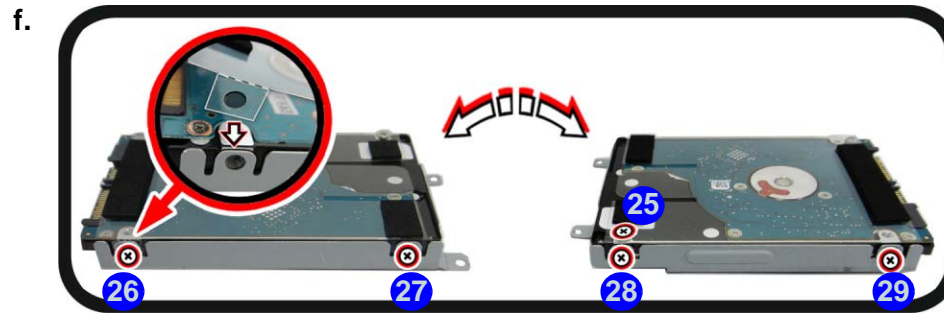

30. HDD  
 31. Bracket  
 32. Mylar Cover
- 5 Screws

### Installing 9.5mm or 7mm HDD

Note that the hard disks pictured on these pages are all 9.5mm(h) hard disk drive.

In some cases, a 7.0mm(h) hard disk drive will be installed. Do pay attention on the alignment of the hard disk and bracket when tightening the screws.

For more information, contact your distributor/supplier, and bear in mind your warranty terms.

### Hard Disk Size Note (Foam Rubber Insert)

Note that the hard disks pictured on these pages are all 9.5mm(H) hard disk drives. In some cases 7mm(H) hard disk drives will be installed. Also pay attention on the alignment of the hard disk and bracket when tightening the screws.

For more information contact your distributor/supplier, and bear in mind your warranty terms.

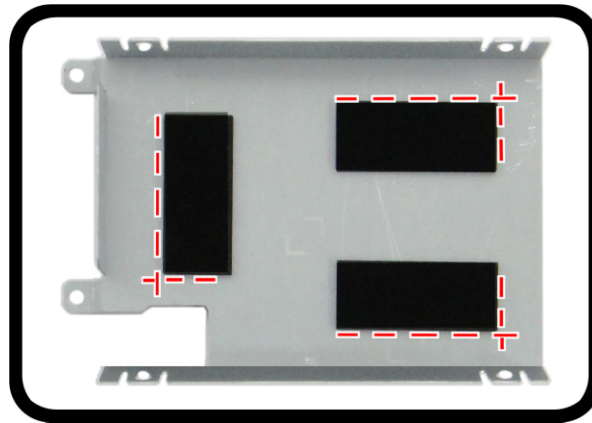

*Figure 5*  
**Foam Rubber  
Insert for 7mm(H)  
HDDs**

- If you are replacing a 9.5mm(H) HDD with a 7mm(H) HDD then insert the foam rubber insert (as shown above).
- If you are replacing a 7mm(H) HDD with a 9.5mm(H) HDD then remove the foam rubber insert.



## Disassembly

*Figure 6*  
Optical Device  
Removal

- Push the optical device out of the computer.
- Pry the bezel off the optical device.
- Separate the bezel and optical device.
- Install the front bezel.

## Removing the Optical (CD/DVD) Device

- Turn **off** the computer, remove the battery ([page 2 - 5](#)), and bottom case ([page 2 - 6](#)).
- Carefully push out the optical device **1** out of the bay in the direction of the arrow **2** ([Figure 6a](#)).
- Carefully pry the bezel **4** off the optical device at point **3** ([Figure 6b](#)).
- Separate the bezel **4** and the optical device ([Figure 6d](#)).
- Reverse the process to attach the front bezel **4** with the new optical device at point **5** ([Figure 6d](#)).
- Insert the new device and carefully slide it into the computer (the device only fits one way. **DO NOT FORCE IT**; The screw holes should line up). Replace the bottom cover and tighten the screws.
- Restart the computer to allow it to automatically detect the new device.

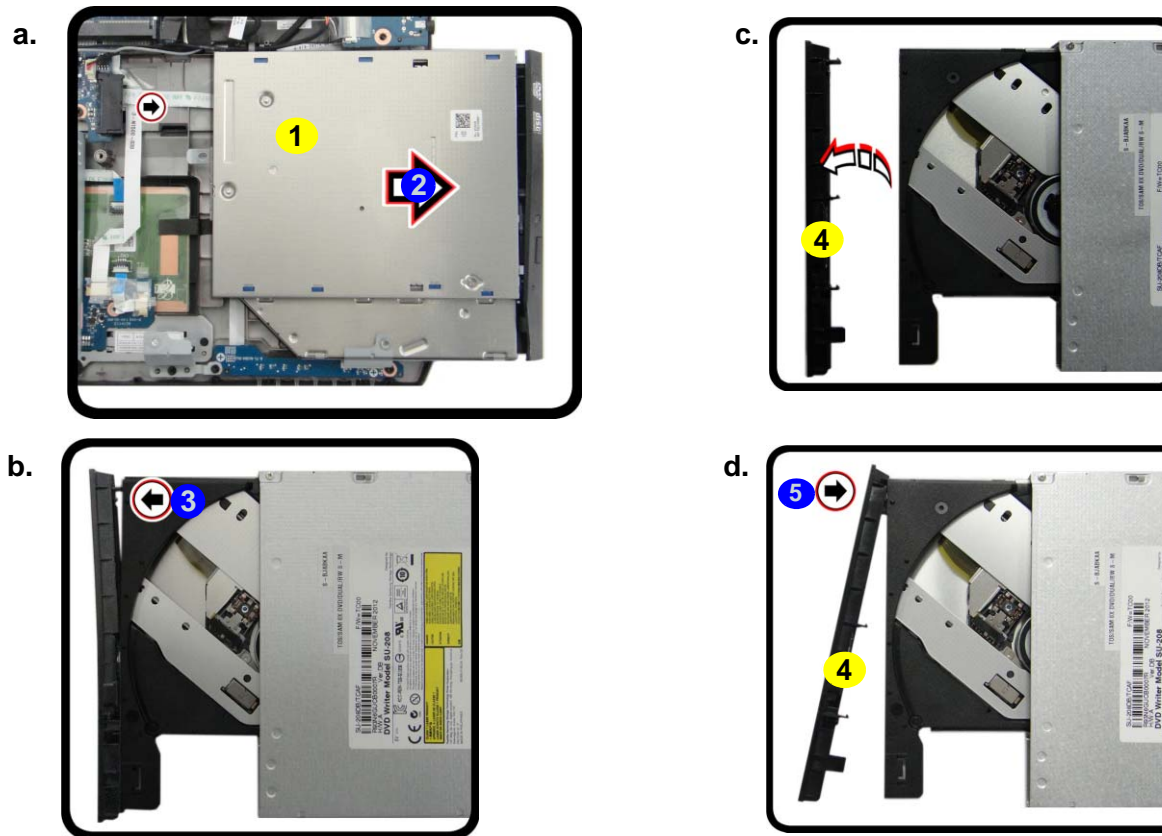

- Optical Device
- Bezel Cover

## Removing the Keyboard

1. Turn **off** the computer, remove the battery ([page 2 - 5](#)), and bottom case ([page 2 - 6](#)).
2. Open it up with the LCD on a flat surface before pressing at points **1** & **2** to release the keyboard module (use the special eject stick to do this) while releasing the keyboard in the direction of the arrow **3** as shown ([Figure 7a](#)).
3. Carefully lift the keyboard **4** up, being careful not to bend the keyboard ribbon cable **5**. Disconnect the keyboard ribbon cable **5** from the locking collar socket by using a flat-head screwdriver to pry the locking collar pins **6** away from the base ([Figure 7b](#)).
4. Carefully lift the keyboard **4** off the computer ([Figure 7c](#)).

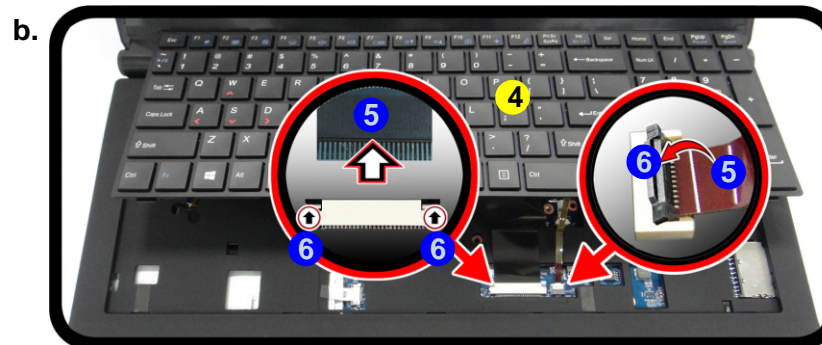
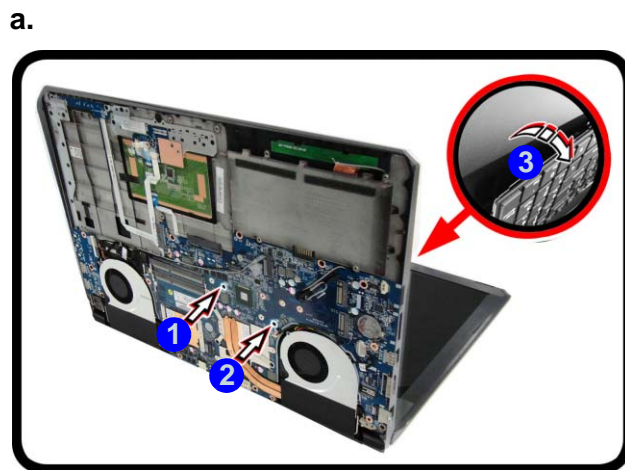

Figure 7

### Keyboard Removal

- a. Eject the keyboard using a special eject stick to push the keyboard out while releasing the keyboard as shown.
- b. Lift the keyboard up and disconnect the keyboard ribbon cable from the locking collar socket.
- c. Remove the keyboard.



#### Re-inserting the Keyboard

When re-inserting the keyboard firstly, align the keyboard tabs at the bottom of the keyboard with the slots in the case.



4. Keyboard

*Figure 8*  
**RAM Module Removal**

- The RAM modules will be visible at point **1** on the mainboard.
- Pull the release latches.
- Remove the module.



### Contact Warning

Be careful not to touch the metal pins on the module's connecting edge. Even the cleanest hands have oils which can attract particles, and degrade the module's performance.



### 4. RAM Module

## Removing the System Memory (RAM)

The computer has two memory sockets for 204 pin Small Outline Dual In-line Memory Modules (SO-DIMM) supporting DDR3L up to 1600 MHz. The main memory can be expanded up to 16GB. The total memory size is automatically detected by the POST routine once you turn on your computer.

### Memory Upgrade Process

- Turn **off** the computer, remove the battery ([page 2 - 5](#)), and bottom case ([page 2 - 6](#)).
- The RAM modules will be visible at point **1** on the mainboard ([Figure 8a](#)).
- Gently pull the two release latches (**2** & **3**) on the sides of the memory socket in the direction indicated by the arrows ([Figure 8b](#)). The RAM module **4** will pop-up ([Figure 8c](#)), and you can then remove it.
- Pull the latches to release the second module if necessary.
- Insert a new module holding it at about a 30° angle and fit the connectors firmly into the memory slot.
- The module will only fit one way as defined by its pin alignment. Make sure the module is seated as far into the slot as it will go. **DO NOT FORCE IT**; it should fit without much pressure.
- Press the module in and down towards the mainboard until the slot levers click into place to secure the module.
- Replace the bottom cover and the screws (see [page 2 - 5](#)).
- Restart the computer to allow the BIOS to register the new memory configuration as it starts up.

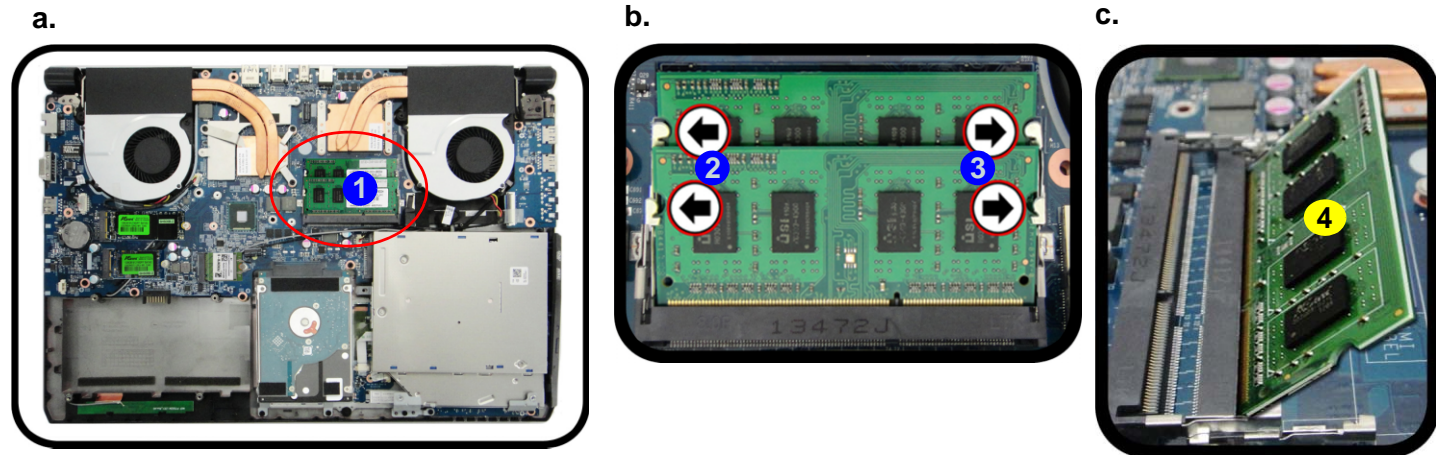





## Removing the M.2 SSD Module

1. Turn **off** the computer, remove the battery ([page 2 - 5](#)), and bottom case ([page 2 - 6](#)).
2. The M.2 SSD module will be visible at point **1** on the mainboard ([Figure 9a](#)).
3. Remove the screw **2** ([Figure 9b](#)).
4. The M.2 SSD module **3** ([Figure 9c](#)) will pop-up, and you can remove it from the computer.
5. Reverse the process to install a new SSD (make sure that the hexagonal screw is in the correct location). Note that a flat-head screw driver can be used to tighten or remove the hexagonal screw as shown ([Figure 9d](#)).

*Figure 9*  
**M.2 SSD Module Removal**

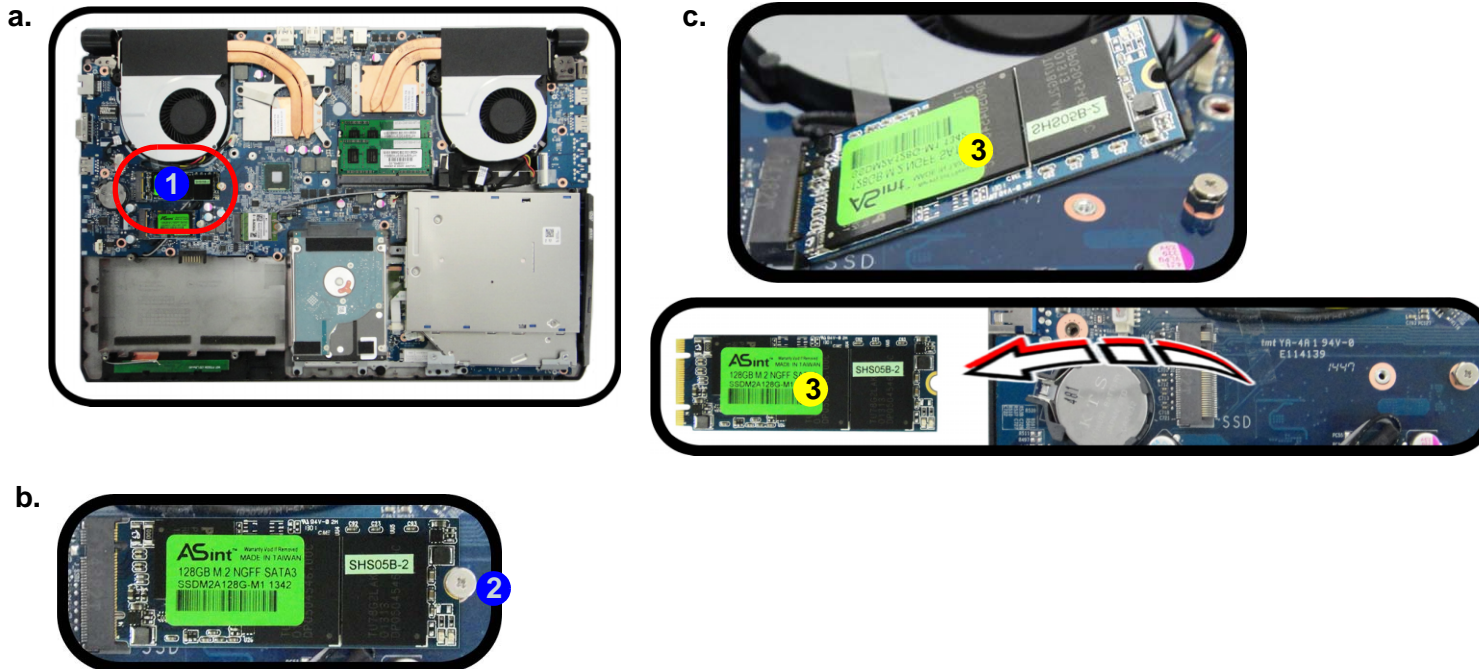
- a. Locate the M.2 SSD.
- b. Remove the screw.
- c. The M.2 SSD module will pop up.





3.M2 SSD Module

- 1 Screw

## Disassembly

Figure 10  
Wireless LAN  
Module Removal

- Locate the WLAN.
- Disconnect the cables and remove the screw.
- The WLAN module will pop up.

Note: Make sure you reconnect the antenna cable to the “1 + 2” socket (Figure 10b).

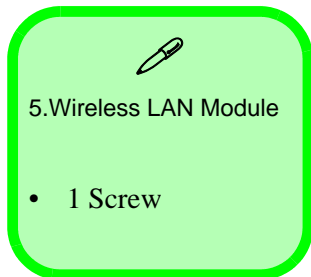

## Removing the Wireless LAN Module

- Turn off the computer, remove the battery (page 2 - 5), keyboard (page 2 - 11) and bottom case (page 2 - 6).
- The Wireless LAN module will be visible at point 1 on the mainboard (Figure 10a).
- Carefully disconnect the cables 2 & 3, and then remove the screw 4 (Figure 10b)
- The Wireless LAN module 5 (Figure 10c) will pop-up, and you can remove it from the computer.

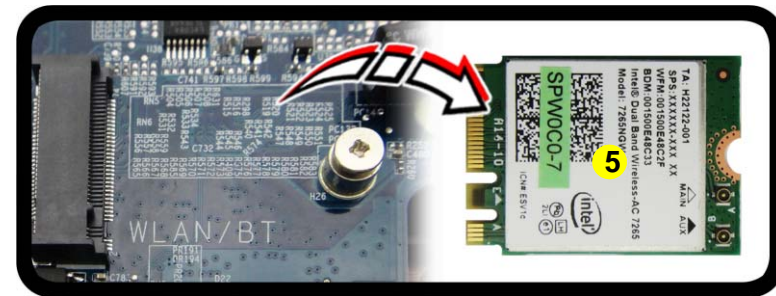
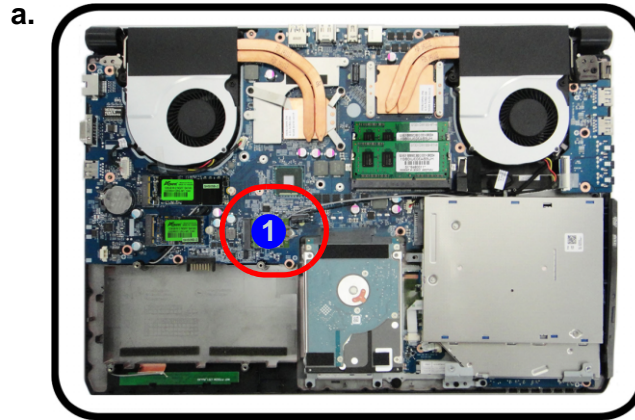

## Wireless LAN, Combo, 3G & LTE Module Cables

Note that the cables for connecting to the antennae on WLAN, WLAN & Bluetooth Combo, 3G and LTE modules are not labelled. The cables/covers (each cable will have either a black or transparent cable cover) are color coded for identification as outlined in the table below.

Module Type	Antenna Type	Cable Color	Cable Cover Type
WLAN/WLAN & Bluetooth Combo	WM 1	Black	Transparent
	WM 2	Gray	White
LTE Broadband	LTE 1	Black	Black
	LTE 2	Gray	
3G Broadband	3G 1	Black	Black
	3G 2	Gray	

Cable 1 is usually connected to antenna 1 (Main) on the module, and cable 2 to antenna 2 (Aux).

## Disassembly

Figure 11  
3G/4G Module  
Removal

## Removing the 3G/4G Module

### 3G/4G Module Removal Procedure

1. Turn off the computer, remove the battery ([page 2 - 5](#)), and bottom case ([page 2 - 6](#)).
  2. Locate the module, it is visible at point **1** ([Figure 11a](#)).
  3. Carefully disconnect the cables **2** & **3**, and then remove the screw **4** from the module ([Figure 11b](#)).
  4. The module **3** will pop-up ([Figure 11c](#)).
  5. Lift the module **5** up and off the computer ([Figure 11d](#)).
- a. Locate the module.
  - b. Disconnect the cables and remove the screw.
  - c. The module will pop-up.
  - d. Lift the module up off the socket.

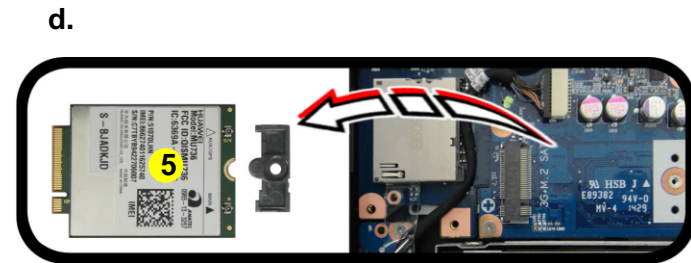
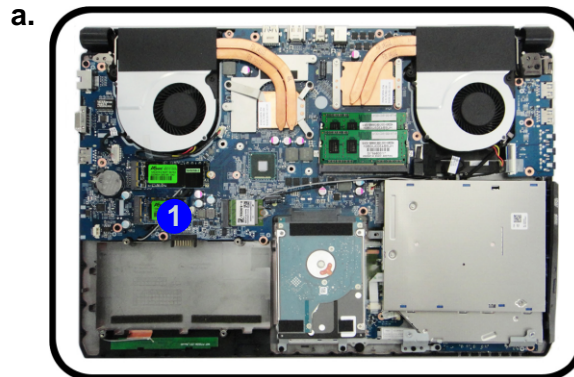

5. 3G/4G Module

- 1 Screw

---

# Appendix A:Part Lists

This appendix breaks down the *N150RD / N151RD* series notebook's construction into a series of illustrations. The component part numbers are indicated in the tables opposite the drawings.

**Note:** This section indicates the *manufacturer's* part numbers. Your organization may use a different system, so be sure to cross-check any relevant documentation.

**Note:** Some assemblies may have parts in common (especially screws). However, the part lists DO NOT indicate the total number of duplicated parts used.

**Note:** Be sure to check any update notices. The parts shown in these illustrations are appropriate for the system at the time of publication. Over the product life, some parts may be improved or re-configured, resulting in *new* part numbers.

---

## Part List Illustration Location

The following table indicates where to find the appropriate part list illustration.

*Table A - 1*  
**Part List Illustration  
Location**

Part	
Top	<i>page A - 3</i>
Bottom	<i>page A - 4</i>
Main Board	<i>page A - 5</i>
HDD	<i>page A - 6</i>
2nd HDD	<i>page A - 7</i>
LCD	<i>page A - 8</i>
DVD	<i>page A - 9</i>
Dummy ODD	<i>page A - 10</i>



# Top

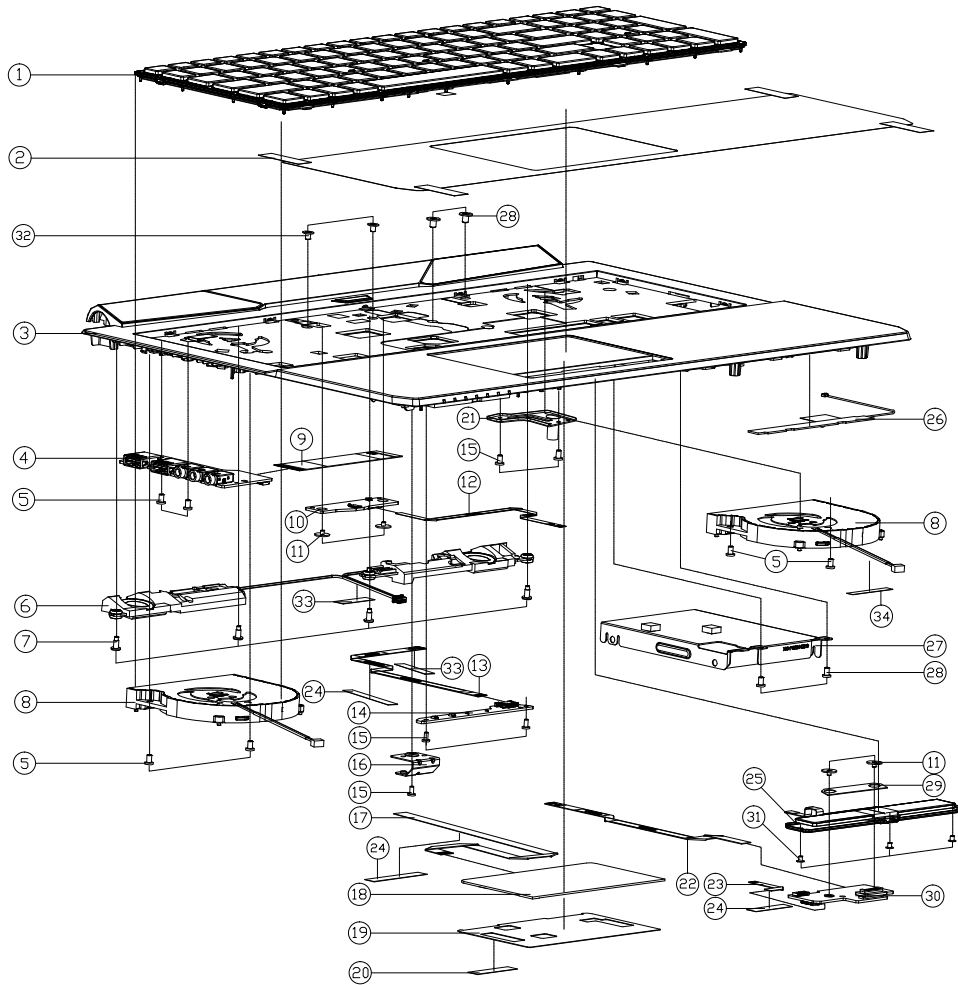

ITEM	PART NAME	PART NO	REMARK
1	W/O HD W/ PROTECTION PASTE BLACK COATED WITH VMD KEY + VIO FRAME	6-80-P6500-013-1	
2	TOP CASE PROTECT MYLAR PET N150SD	6-40-N1502-041	
3	TOP CASE MODULE (INKYOKKAPDK) N150SD	6-39-N1502-013-N	
3	TOP CASE MODULE (INKYOKKAPDK) N151SD	6-39-N1512-011-N	
4	AUDIO BOARD V1.0 N150RD	6-77-N15R8-D01	
5	SCREW M2.5*4L K1 BK/O ICT NY	6-35-B4125-4RA	
6	SPK CABLE FROM P/L SH41 T52 2W 41 E03P6H0303000LY AUDIO P/2730M	6-23-SP177-012-A	
7	SCREW M2*6.2L NI ICT NY FOR SPEAKER	6-35-Z1120-6R2	
8	FAN MODULE (A-POWER) N150SD	6-31-N1502-301	
9	FFC CABLE FOR AUDIO BOARD TO MB 73MM 60V 4P (CNLS) N650	6-43-N1500-061	
10	LID PWR SW BOARD V2.0 N150SD	6-77-N150S-D02	
11	SCREW M2*2L K1 BK/Z ICT NY(Ø8,T=0.6)	6-35-B6120-2RE	
12	FFC CABLE FOR POWER 30 TO MB 1483MM 60V 8P (CNLS) N650	6-43-N1500-050	
13	FFC CABLE FOR LED TO MB 1845MM 60V 12P (CNLS) N650	6-43-N1500-041	
14	FRONT LED BOARD V1.0 N150RD	6-77-N1574-D01-A	
15	SCREW M2*4L K1 BZ ICT NY	6-35-B6120-4RA	
16	TOP CASE BOSS BKT 01 (SECC) N150SD	6-33-N1502-021	
17	FFC CABLE TP TO MB 1483MM 60V 4P (NO HDD) N1570-V	6-43-N1570-011	
18	TOUCH PAD SYNAPTICS TM-03189-001000453MM0 N250LU	6-49-N2503-010	
19	TOUCH PAD MYLAR (PET + TESA 4972) N170SD	6-40-N1702-051	
20	GASKET BLACK (30*7*0.13T) W370ET	6-47-00190-016	
21	TOP CASE BOSS BKT 02 (SECC) N150SD	6-33-N1502-032	
22	FFC CABLE FOR FP TO MB 163MM 60V 6P (CNLS) N650	6-43-N1500-031	ONLY FOR W/FINGER
23	FFC CABLE FOR CLICK TO TP 32MM 60V 4P (CNLS) N650	6-43-N1500-021	
24	TAPE MYLAR (A) MYLAR M550J	6-40-M55J2-010	
25	FUNCTION KEY FOR CLICK BUTTON MODULE W/FINGER/22849400 P650E	6-23-KP650-014	FOR N151RD
25	FUNCTION KEY FOR CLICK BUTTON MODULE W/FP P750M	6-23-KP75D-011	FOR N150RD
25	FUNCTION KEY FOR CLICK BUTTON MODULE W/FINGER/22849400 P650E	6-23-KP650-023	FOR N151RD
25	FUNCTION KEY FOR CLICK BUTTON MODULE W/O FP P750M	6-23-KP75D-021	FOR N150RD
26	W/O HD W/ PROTECTION PASTE BLACK COATED WITH VMD KEY + VIO FRAME	6-23-7N150-020	
27	W/O MAIN HDD ASS'Y N150SD	6-79-N150SD0J-010	
27	W/MAIN HDD ASS'Y N150SD	6-79-N150SD0J-020	
28	SCREW M2.5*3L K1 BZ ICT NY	6-35-B6125-3R0	
29	CLICK W/O FP MYLAR PET (48H*4*0.5T) P650SE	6-40-P6502-080	ONLY FOR W/O FINGER
30	CLICK FINGER BOARD V2.0(FINGER PRINT BOARD V1.0) N650	6-77-N150A-N02	
30	CLICK FINGER BOARD V2.0 (W/O FP) N150SD	6-77-N1502-D02-1	
31	SCREW M2*2.5L K1 NI ICT NY (Ø4 T=0.5 TH)	6-35-B1120-2R6	
32	SCREW M2*3L K1 NI ICT NY (ØD=Ø4.5,DT=0.4)	6-35-B1120-3RE	
33	TAPE MYLAR (C) MYLAR M550J	6-40-M55J2-030	
34	TAPE MYLAR (B) MYLAR M550J	6-40-M55J2-020	

Figure A - 1  
Top

# Bottom

Figure A - 2  
Bottom

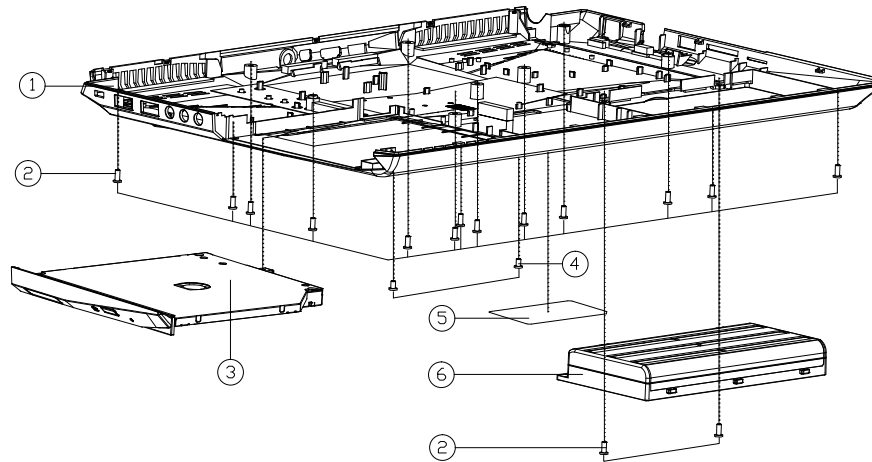

ITEM	PART NAME	PART NO	REMARK
1	BOTTOM CASE MODULE N150SD	6-39-N1503-012	
2	SCREW M2.5*6L K BZ ICT NY	6-35-82125-6RA	
3	W/O ODD ASS'Y N150SD	6-79-N150SD0Z-000	
3	DUMMY ODD ASS'Y N150SD	6-79-N150SD0Z-001	
3	SATA DVD SUPER MULTI 8X ASS'Y N150SD	6-79-N150SD00-001	
3	SATA BLU-RAY COMBO 6X ASS'Y N150SD	6-79-N150SD0W-001	
4	SCREW M2.5*4L K1 BK/O ICT NY	6-35-B4125-4RA	
5	PRODUCT LABEL FOR N150SD	6-45-N150SD03-010	
5	PRODUCT LABEL FOR N150SC	6-45-N150SC03-010	
5	PRODUCT LABEL FOR N150RD	6-45-N150RD03-010	
5	PRODUCT LABEL FOR N151RD	6-45-N151RD03-010	
6	BEZEL S LI 111V280A/G28H 322P 08P/30H 080R25D 980/028P (TEXTURE) N150SD	6-87-N150S-4292	
6	BEZEL S LI 111V280A/G28H 322P 021A/C/SMTD 080R25D 980/028P (TEXTURE) N150SD	6-87-N150S-4U92	



# Main Board

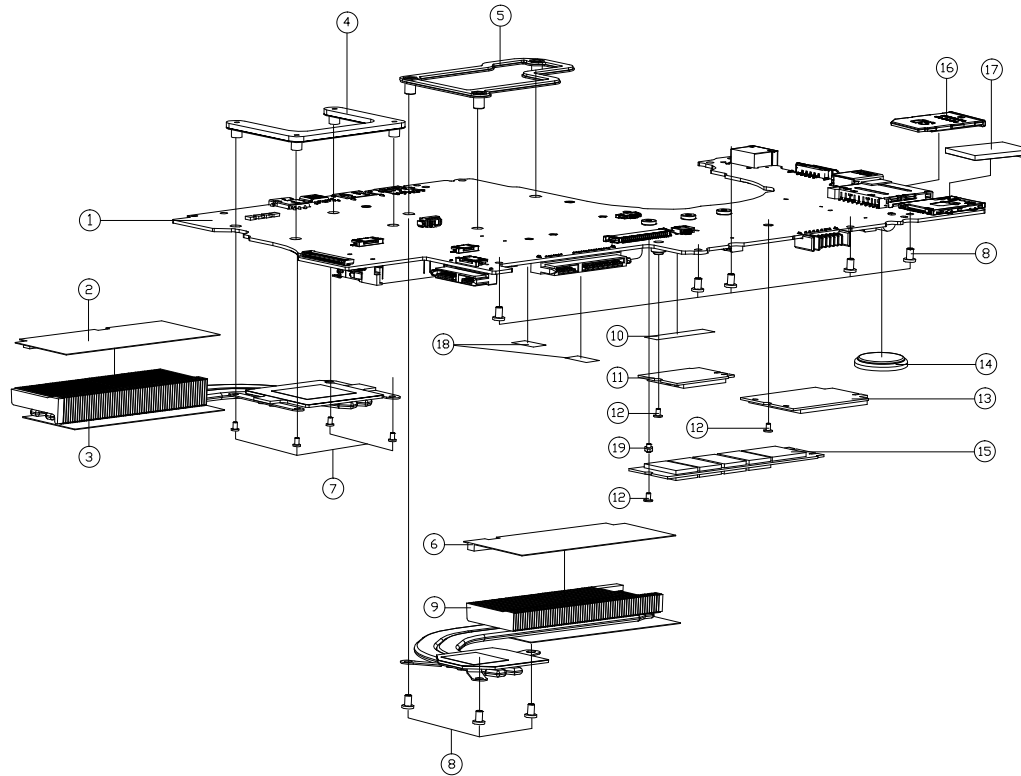

ITEM	PART NAME	PART NO	REMARK
1	MAIN BOARD(PIV7-638MM/230 VZM CQPXW/TPMLTD M390)	6-77-NISOR00-102A-C	
1	MAIN BOARD(PIV7-638MM/230 VZM CQPXW/TPMLTD M390)	6-77-NISOR00-102A-E	
1	MAIN BOARD(PIV5-638MM/230 VZM CQPXW/TPMLTD M390)	6-77-NISOR00-102A-G	
1	MAIN BOARD(PIV5-638MM/230 VZM CQPXW/TPMLTD M390)	6-77-NISOR00-102A-3E	
1	MAIN BOARD(PIV5-638MM/230 VZM CQPXW/TPMLTD M390)	6-77-NISOR00-102A-3G	
2	MYLAR TOP CPU R OUTLAR+SPONGE+SDMY (6000) M390	6-40-NI502-0R1	
3	CPU HEATSINK MODULE NISORD	6-31-NI5R2-101	
4	CPU SUPPORT BRACKET SECC I-15 P150H	6-33-X510S-011	
5	VGA SUPPORTER SECC W150ERQ	6-33-W15ES-012	
6	MYLAR TOP VGA L OUTLAR+SPONGE+SDMY (6000) M390	6-40-NI502-0L1	
7	SCREW M2X3L KI NI ICT NY (OD=44.5,DT=8.4)	6-35-B1120-3RE	
8	SCREW M2.5X4L KI BK/D ICT NY	6-35-B4125-4RA	
9	GPU HEATSINK MODULE NIS0SD	6-31-NI502-201	
10	TAPE MYLAR (B)MYLAR M550J	6-40-M55J2-020	
11	WARRANTY LABEL FOR CPU/HEATSINK SUPPORT KIT (2X22.2X18.2MM) (OPTIONAL)	6-88-W95LF-4220	OPTION
11	WARRANTY LABEL FOR CPU/HEATSINK SUPPORT KIT (2X22.2X18.2MM) (OPTIONAL)	6-88-W95LF-4240	OPTION
11	WARRANTY LABEL FOR GPU/HEATSINK SUPPORT KIT (2X22.2X18.2MM) (OPTIONAL)	6-88-W240F-4200	OPTION
11	WARRANTY LABEL FOR CPU/HEATSINK SUPPORT KIT (2X22.2X18.2MM) (OPTIONAL)	6-88-P75DF-9601	OPTION
11	WARRANTY LABEL FOR CPU/HEATSINK SUPPORT KIT (2X22.2X18.2MM) (OPTIONAL)	6-88-S210F-9400	OPTION
11	WARRANTY LABEL FOR CPU/HEATSINK SUPPORT KIT (2X22.2X18.2MM) (OPTIONAL)	6-88-N170F-5100	OPTION
11	WARRANTY LABEL FOR CPU/HEATSINK SUPPORT KIT (2X22.2X18.2MM) (OPTIONAL)	6-88-P75DF-9600	OPTION
11	WARRANTY LABEL FOR GPU/HEATSINK SUPPORT KIT (2X22.2X18.2MM) (OPTIONAL)	6-88-P67RF-4200	OPTION
12	SCREW M2X2L KI NI ICT NY (OD=4.5 J=0.5)	6-35-B1120-2R0	
13	WARRANTY LABEL FOR CPU/HEATSINK SUPPORT KIT (2X22.2X18.2MM) (OPTIONAL)	6-88-S210W-8810	
13	WARRANTY LABEL FOR CPU/HEATSINK SUPPORT KIT (2X22.2X18.2MM) (OPTIONAL)	6-88-W3306-8841	
13	WARRANTY LABEL FOR CPU/HEATSINK SUPPORT KIT (2X22.2X18.2MM) (OPTIONAL)	6-88-W3306-8830	
14	BATTERY 3V 220MA BBBCR2032B (KTS)	6-23-6A2B2-030	
15	SSD M2 2280 SATA 300GB W/PCIE/ATA SATA 300GB MLC	6-85-D515B-S00	OPTION
15	SSD M2 2280 SATA 600GB W/PCIE/ATA SATA 600GB MLC	6-85-D515A-100	OPTION
15	SSD M2 2280 SATA 600GB W/PCIE/ATA SATA 600GB MLC	6-85-D515B-S01	OPTION
15	SSD M2 2280 SATA 600GB W/PCIE/ATA SATA 600GB MLC	6-85-D513G-200	OPTION
15	SSD M2 2280 SATA 600GB W/PCIE/ATA SATA 600GB MLC	6-85-D515B-S02	OPTION
16	JUMPER 3D PUSH TYPE PC+ABS (C7222P-7002) W/PSHOW	6-42-W9708-010	
17	V/D 36 RUBBER (2624192)SILICON RUBBER P639SC	6-47-P6502-020	V/D 36 MODULE AND 36 ANTENNA
18	TAPE MYLAR TRANSPARENT (28MMX405) P199HM	6-40-P1803-020	
19	SCREW M2X2 0R25 P01 STEEL (K) NY FOR W/F ORANGE (M35M)	6-35-ZA120-2R5	

Figure A - 3  
Main Board

# HDD

Figure A - 4  
HDD

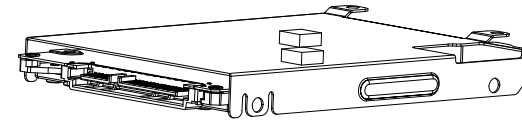
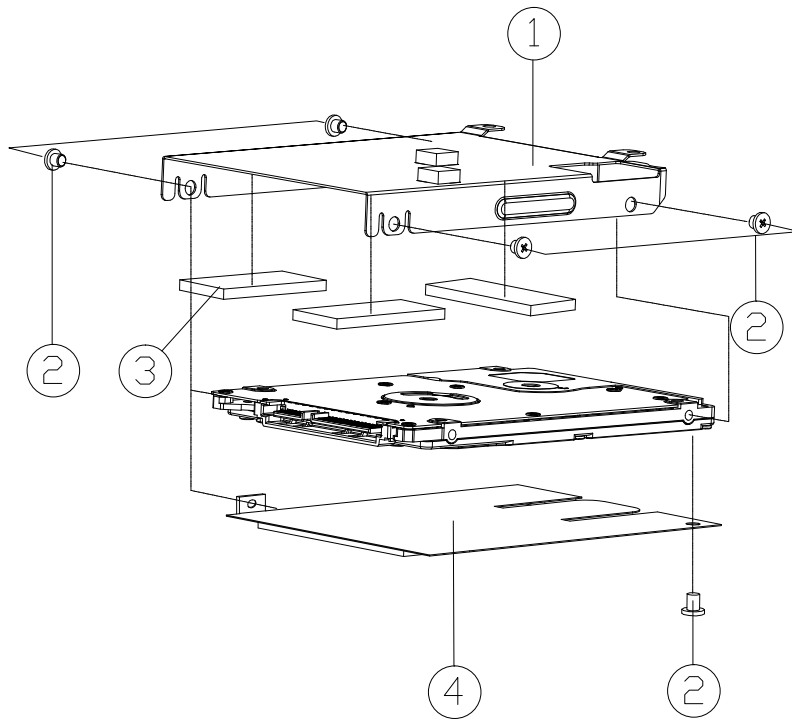

ITEM	PART NAME	PART NO	REMARK
1	HDD BRACKET (SECC+CR2030) N150SD	6-33-N150J-011	
2	SCREW M3*2.5L KI NI ICT NY	6-35-B1130-2R5	
3	7MM HDD BKT SPONGE (35*15*2.5) CR2030 N150SD	6-47-0019A-355	
4	HDD MYLAR (PET0.25T+CR2030) W940TU	6-40-W940J-010	

# 2nd HDD

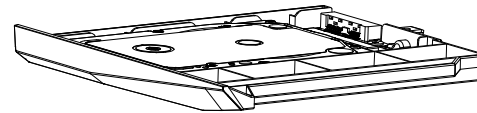
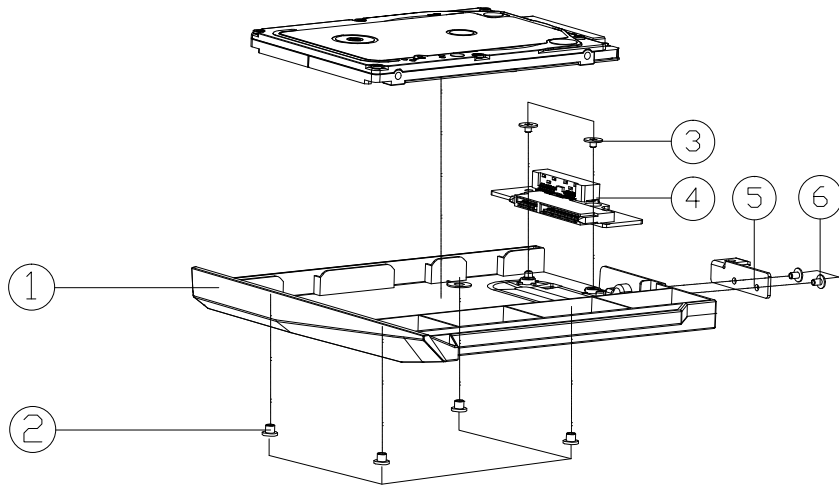

Figure A - 5  
2nd HDD

ITEM	PART NAME	PART NO	REMARK
1	DUMMY ODD MODULE N150SD	6-42-N150Z-201	
2	SCREW M3*2.5L KI NI ICT NY	6-35-B1130-2R5	
3	SCREW M2*2L KI BK/2 ICT NY (ø6,T=0.5)	6-35-B6120-2RC	
4	ODD BOARD V3.0 N150SD	6-77-W95KN-D13-B	
5	ODD LOCK BRKT (SECC 0.5T) N150SD	6-33-N150Z-011	
6	SCREW M2*3L KI NI ICT NY (DD=ø4.5,DT=0.4)	6-35-B1120-3RE	

# LCD

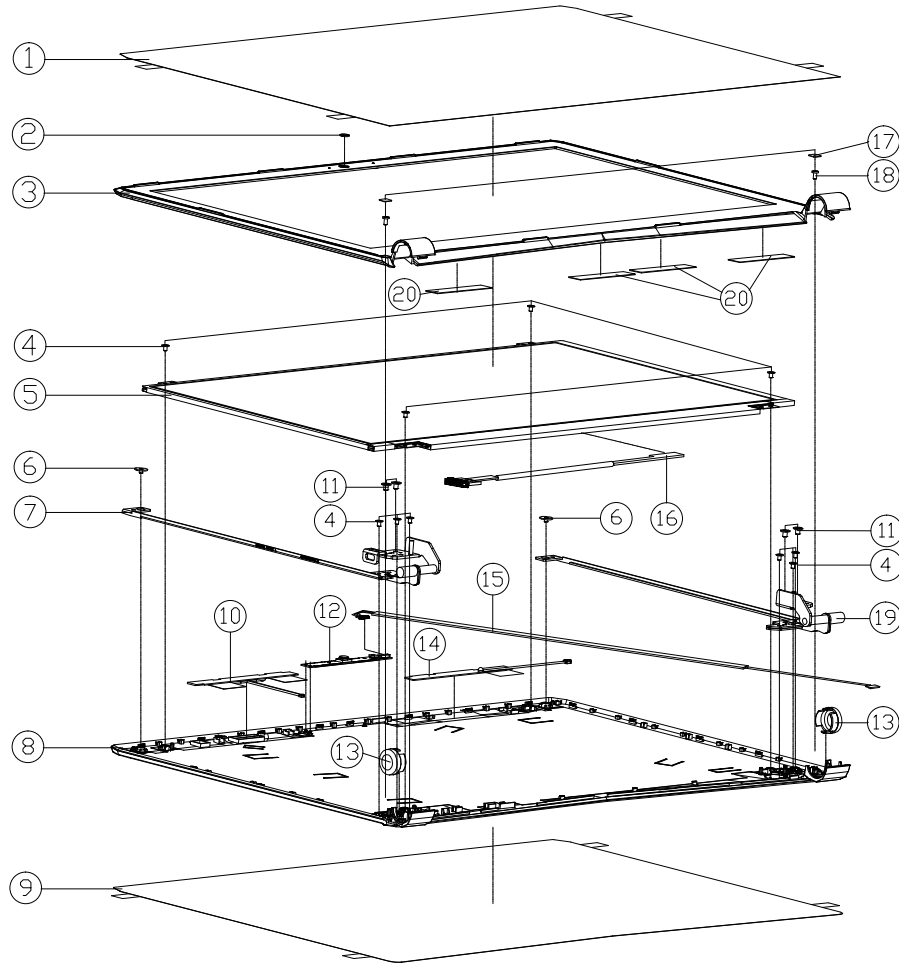

Figure A - 6  
LCD

A.Part Lists

ITEM	PART NAME	PART NO	REMARK
1	FRONT COVER PROTECTION PET MYLAR N150SD	6-40-N1508-020	
2	CCD LENS (VIEWING AREA 4MMX3MM)W940TU	6-42-W9401-020	
3	LCD FRONT COVER MODULE N150SD	6-39-N1501-012	FDR N150SD/SC
3	LCD FRONT COVER MODULE N150RD	6-39-N15R1-010	FDR N150RD
3	LCD FRONT COVER MODULE (WANSUNG)ROSSMONSTERP/NESOROKKAPKO	6-39-N15R1-010-B	FDR N151RD
4	SCREW M2X3L KI NI ICT NY (DD=04.5,DT=0.4)	6-35-B1120-3RE	
5	LCD 15.6" FHD EDP BDC HB156FHI-401 (LED) 32 MM	6-50-LB232-Z00	
5	LCD 15.6" FHD EDP CLARE TYPE BDC HB156FHI-301 (LED) 32 MM	6-50-LB232-Z01	
5	LCD 15.6" FHD (IPS) EDP AU B156HMD20HVA1 (N7) (LED) 32MM	6-50-LB232-G11	
5	LCD 15.6" (IPS) EDP SAMSUNG L156HAE-H1 * SUPPORT 5V 6-TONE 32MM	6-50-L1226-M03	
5	LCD 15.6" FHD (IPS) EDP LG L156HAE-SPH (N7) LED SUPPORT 5V 6-TONE 32MM	6-50-LB232-M00	
5	LCD 15.6" FHD (IPS) EDP LG L156HAE-SPH (N7) LED SUPPORT 5V 6-TONE 32MM	6-50-LB232-L04	
5	LCD 15.6" FHD (IPS) EDP LG L156HAE-SPH (N7) LED SUPPORT 5V 6-TONE 32MM	6-50-LB232-L01	
5	LCD 15.6" FHD (IPS) EDP CHIMEI N156HAE-EA1 (LED) 32 MM	6-50-LB232-D03	
6	SCREW M2X2L KI BK/Z ICT NY(08,T=0.6)	6-35-B6120-2RE	
7	HINGE L (SUS430+S50C) SZS N150SD	6-33-N1501-0L2	
8	LCD BACK COVER MODULE (PAINT) N150SDKAPKO	6-39-N1501-022-W	FDR N150SD/RD
8	LCD BACK COVER MODULE (CHANGE PAINT) WANSUNGROSSMONSTERP/NESOROKKAPKO	6-39-N1511-021-B	FDR N151SD/RD
8	LCD BACK COVER MODULE N151SD	6-39-N1511-021	FDR N150SD/RD
9	BACK COVER PROTECTION PET MYLAR N150SD	6-40-N1508-010	
10	ANTENNA PCB 4-KLAW CONDUCTIVE METALIZ FOR 246.5X161-15.0MM W2-0MM N150SD	6-23-7N150-011	
11	SCREW M2.5X4L KI BK/D ICT NY	6-35-B4125-4RA	
12	UV-CAMERA BROWN FOR 120X120X120 IN FHD 0.225X 1.000X 1.000X VFD-MIC W/LED	6-88-A11SC-4900	FDR N150SD/SC
12	UV-CAMERA BROWN FOR 120X120X120 IN FHD 0.225X 1.000X 1.000X VFD-MIC W/LED	6-88-P650C-4900	FDR N150RD
13	HINGE RING (TEJ.JIN TN-3715BX) N150SD	6-42-N1501-011	FDR N150SD/RD
13	HINGE RING (TEJ.JIN TN-3715BX) (CHANGE PAINT) N151SD	6-42-N1511-012	FDR N151SD/RD
14	ANTENNA PCB 4-KLAW CONDUCTIVE METALIZ FOR 246.5X161-15.0MM W2-0MM N150SD	6-23-7P750-030	OPTION
15	WIRE CABLE FOR CCD D-MIC 568.0MM 3.3V 8P (4L) WASO3HQ	6-43-WAS0T-011	
16	WIRE CABLE FOR EDP 35MM 15V 4P/IN (D) (4L/C CONDUCTIVE) N150SD	6-43-N1501-012-L	FDR N150SD/SC/RD
16	WIRE CABLE FOR LVDS 35MM 15V 4P/IN (D) (4L/C CONDUCTIVE) N150SD	6-43-N1501-022-L	FDR N150SD/SC
16	WIRE CABLE FOR EDP 46.35MM 15V 4P/IN (D) (4L/C CONDUCTIVE) N150SD	6-43-N1571-020-L	FDR N150RD
17	FRONT COVER SCREW MYLAR(PC+S)M460(S)S40.35T) N150SD	6-40-N1501-010	
18	SCREW M2X4L KI BZ ICT NY	6-35-B6120-4RA	
19	HINGE R (SUS430+S50C) SZS N150SD	6-33-N1501-0R2	
20	SPONGE ( 42*8.2*0.8) FDR WASO3HQ	6-47-0019A-425	ONLY FOR A10D PANEL 6-50-LB232-G11

# DVD

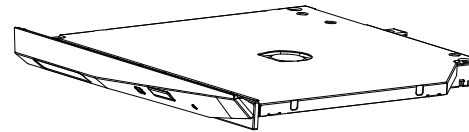
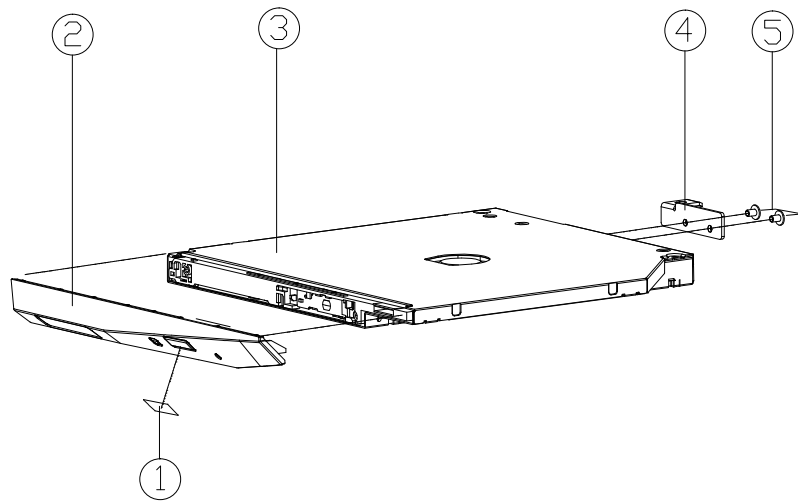
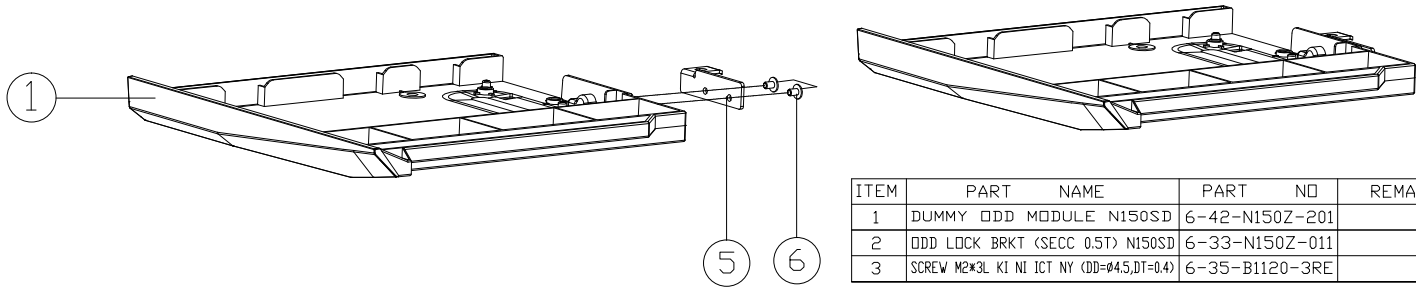

Figure A - 7  
DVD

ITEM	PART NAME	PART NO	REMARK
1	SUPER MULTI ODD BEZEL LABEL (SIZE CHANGE)	6-45-W860Q-012	
2	ODD BEZEL MODULE N150SD	6-42-N150Z-102	
3	SATA DVD SUPER MULTI S 14" BK SCMM ULREZ F/W LINDUN H/W LDR QWV BK PANASONIC	6-85-A088X-P05	FOR PANASONIC
3	SATA DVD SUPER MULTI S 14" BK SCMM ULREZ F/W LINDUN H/W LDR QWV BK TSST	6-85-A088X-T07	FOR TSST
3	SATA DVD SUPER MULTI S 14" BK SCMM ULREZ F/W LINDUN H/W LDR QWV BK PANASONIC	6-85-A088X-P06	FOR PANASONIC
3	SATA DVD SUPER MULTI S 14" BK SCMM ULREZ F/W LINDUN H/W LDR QWV BK PLDS	6-85-A088X-L04	FOR PLDS
4	ODD LOCK BRKT (SECC 0.5T) N150SD	6-33-N150Z-011	
5	SCREW M2x3L KI NI ICT NY (DD-#4.5,DT-0.4)	6-35-B1120-3RE	

# Dummy ODD

Figure A - 8  
Dummy ODD



ITEM	PART NAME	PART NO	REMARK
1	DUMMY ODD MODULE N150SD	6-42-N150Z-201	
2	ODD LOCK BRKT (SECC 0.5T) N150SD	6-33-N150Z-011	
3	SCREW M2*3L KI NI ICT NY (DD=04.5,DT=0.4)	6-35-B1120-3RE	



# Appendix B: Schematic Diagrams

This appendix has circuit diagrams of the *N150RD / N151RD* notebook's PCB's. The following table indicates where to find the appropriate schematic diagram.

Diagram - Page	Diagram - Page	Diagram - Page
<i>System Block Diagram - Page B - 2</i>	<i>PCH 1/9 - Page B - 24</i>	<i>VCore, VCCSA - Page B - 46</i>
<i>Processor 1/7 - Page B - 3</i>	<i>PCH 2/9 - Page B - 25</i>	<i>VCore &amp; VCCSA Output Stage - Page B - 47</i>
<i>Processor 2/7 - Page B - 4</i>	<i>PCH 3/9 - Page B - 26</i>	<i>VCCGT - Page B - 48</i>
<i>Processor 3/7 - Page B - 5</i>	<i>PCH 4/9 - Page B - 27</i>	<i>VCCGT Output Stage - Page B - 49</i>
<i>Processor 4/7 - Page B - 6</i>	<i>PCH 5/9 - Page B - 28</i>	<i>NVVDD - Page B - 50</i>
<i>Processor 5/7 - Page B - 7</i>	<i>PCH 6/9 - Page B - 29</i>	<i>3V3_AON, 3V3_RUN, PEX_VDD - Page B - 51</i>
<i>Processor 6/7 - Page B - 8</i>	<i>PCH 7/9 - Page B - 30</i>	<i>FBVDDQ - Page B - 52</i>
<i>Processor 7/7 - Page B - 9</i>	<i>PCH 8/9 - Page B - 31</i>	<i>AC-In, Charger - Page B - 53</i>
<i>DDR3 SO-DIMM A_0 - Page B - 10</i>	<i>PCH 9/9 - Page B - 32</i>	<i>N155, N157 KB LED, PWR Board - Page B - 54</i>
<i>DDR3 SO-DIMM B_0 - Page B - 11</i>	<i>WLAN, 4G, Fan, Audio Con - Page B - 33</i>	<i>Audio Board - Page B - 55</i>
<i>PS8625 - Page B - 12</i>	<i>CCD, M-Key, Click Conn - Page B - 34</i>	<i>Front LED Board - Page B - 56</i>
<i>Panel, BKL Control - Page B - 13</i>	<i>USB 3.0, USB Charger - Page B - 35</i>	<i>Click / Finger Con Board - Page B - 57</i>
<i>RTD2168 - Page B - 14</i>	<i>LAN RTL8411B, Card Reader - Page B - 36</i>	<i>Fingerprint Board - Page B - 58</i>
<i>Mini DP Port - Page B - 15</i>	<i>HDMI, PS8407A - Page B - 37</i>	<i>N150 LID, PWR SW Board - Page B - 59</i>
<i>VGA Frame Buffer Interface - Page B - 16</i>	<i>Audio Codec ALC269 - Page B - 38</i>	<i>N170 LID, PWR SW Board - Page B - 60</i>
<i>VGA Frame Buffer A - Page B - 17</i>	<i>HDD, TPM, KB LED, PWR Con, T/P - Page B - 39</i>	<i>N170 ODD Ext. Board - Page B - 61</i>
<i>VGA Frame Buffer A - Page B - 18</i>	<i>KBC-ITE IT8587 - Page B - 40</i>	<i>Power Sequence - Page B - 62</i>
<i>VGA PCI-E Interface - Page B - 19</i>	<i>System Power - Page B - 41</i>	<i>Option BOM - Page B - 63</i>
<i>VGA Frame Buffer B - Page B - 20</i>	<i>VDD3, VDD5 - Page B - 42</i>	
<i>VGA Frame Buffer B - Page B - 21</i>	<i>DRAM Power - Page B - 43</i>	
<i>VGA I/O - Page B - 22</i>	<i>Power 1.0V, VCCIO - Page B - 44</i>	
<i>VGA NVVDD Decoupling - Page B - 23</i>	<i>1.0DX_VCCSTG/VCCSFR_OC - Page B - 45</i>	

*Table B - 1*  
**SCHEMATIC  
DIAGRAMS**



### Version Note

The schematic diagrams in this chapter are based upon version 6-7P-N15R9-003. If your mainboard (or other boards) are a later version, please check with the Service Center for updated diagrams (if required).

# System Block Diagram

Sheet 1 of 62  
System Block  
Diagram

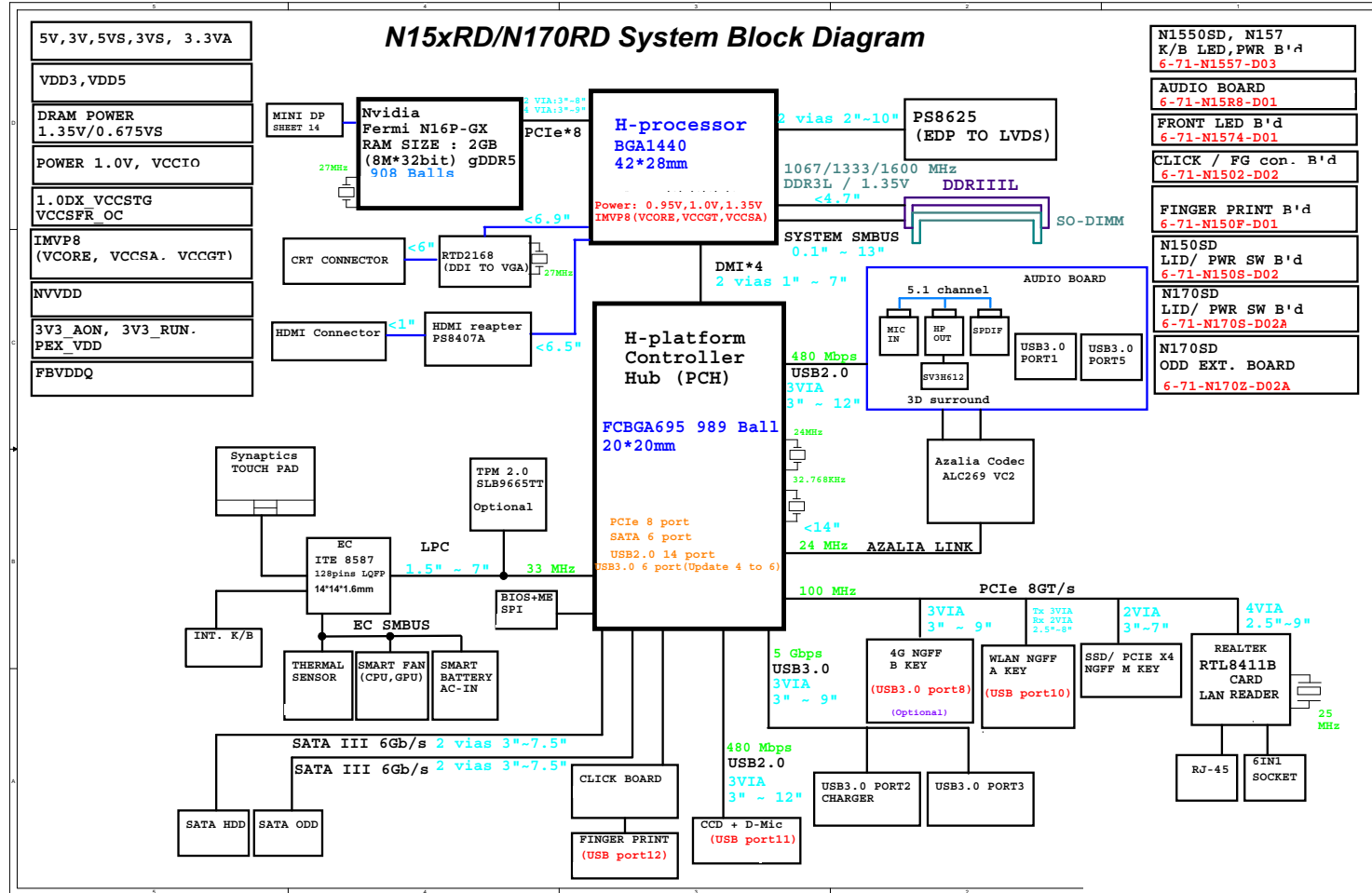

# Processor 1/7

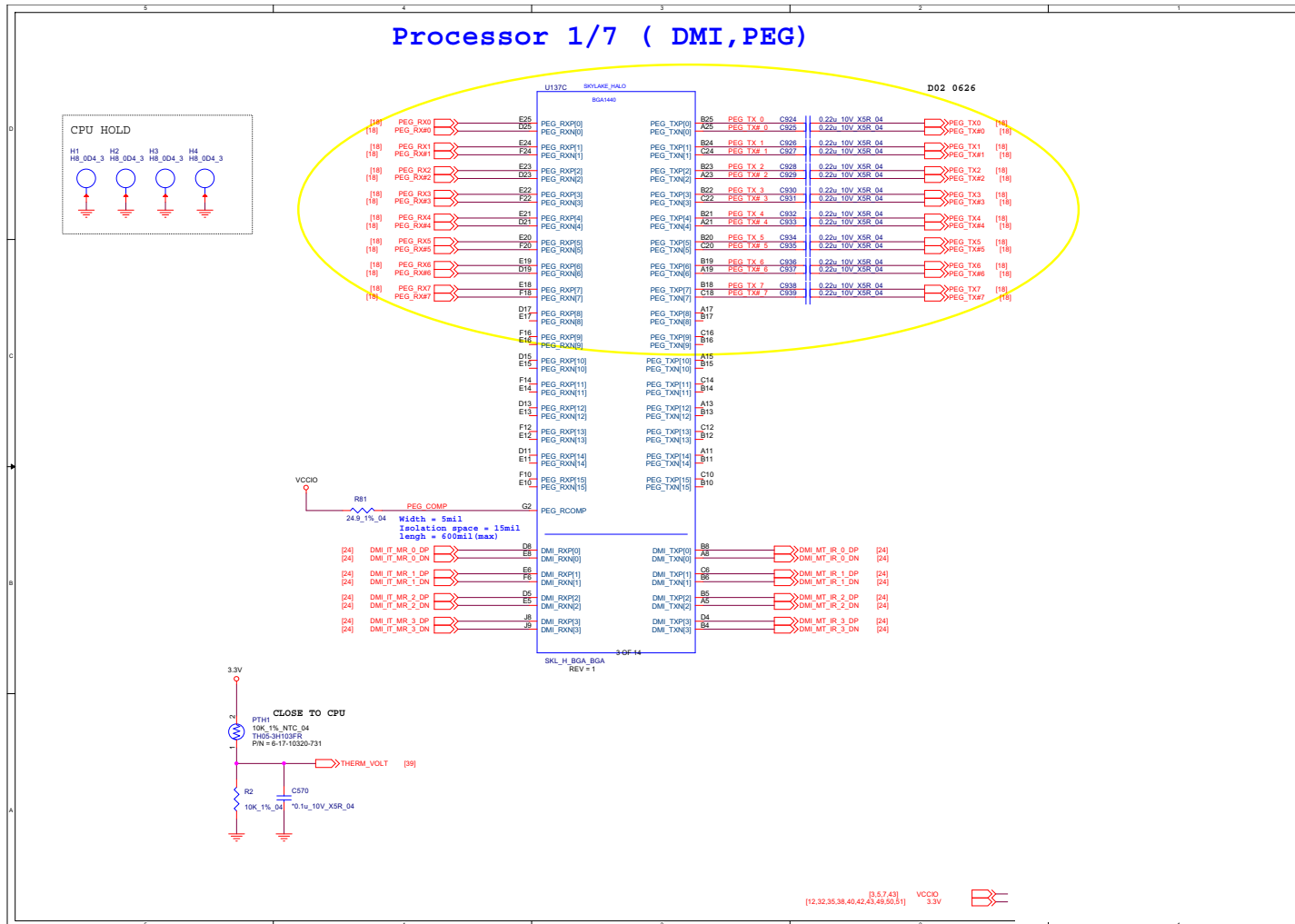

Sheet 2 of 62  
Processor 1/7

# Processor 2/7

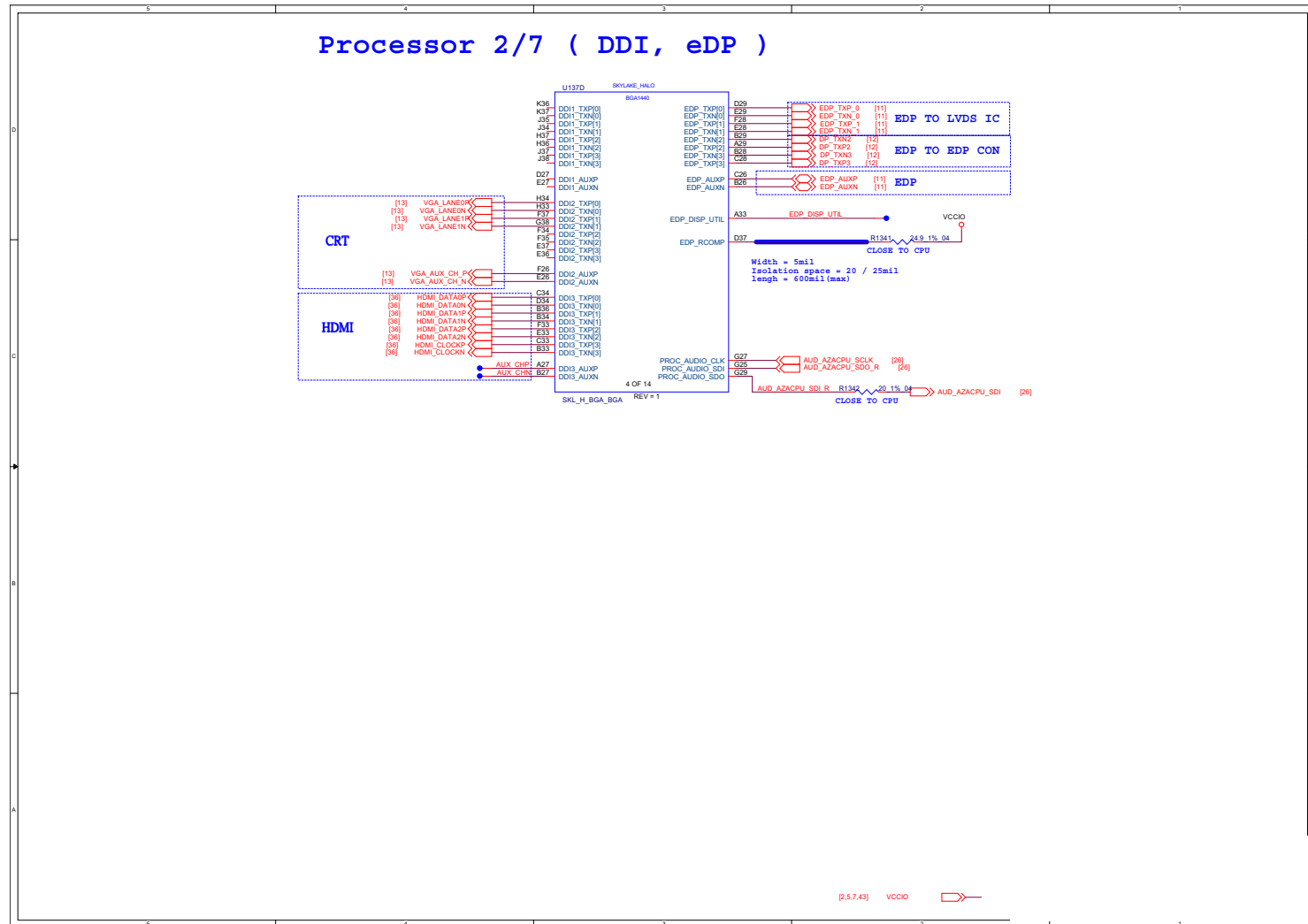

# Processor 3/7

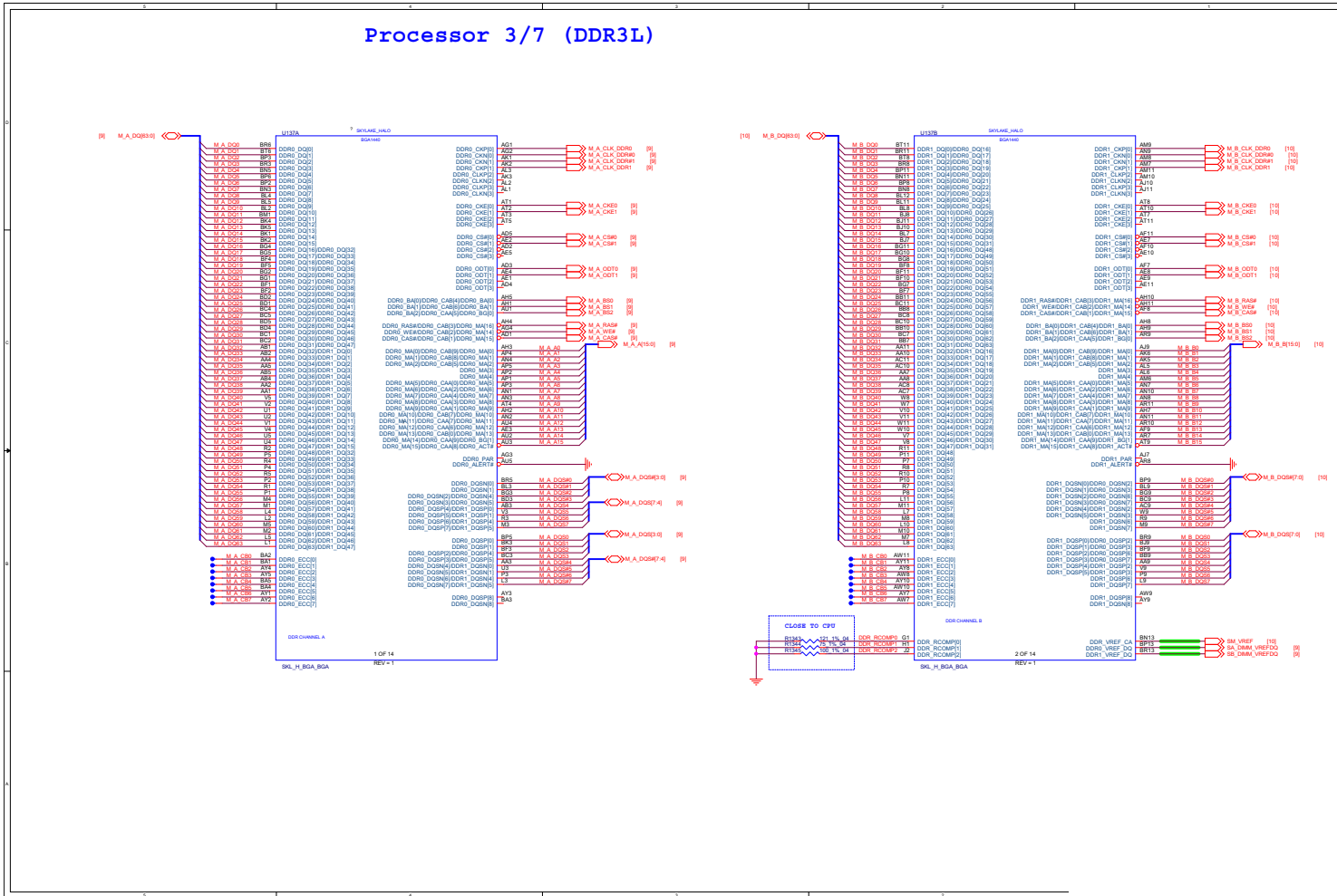

Sheet 4 of 62  
Processor 3/7

B.Schematic Diagrams







# Processor 6/7

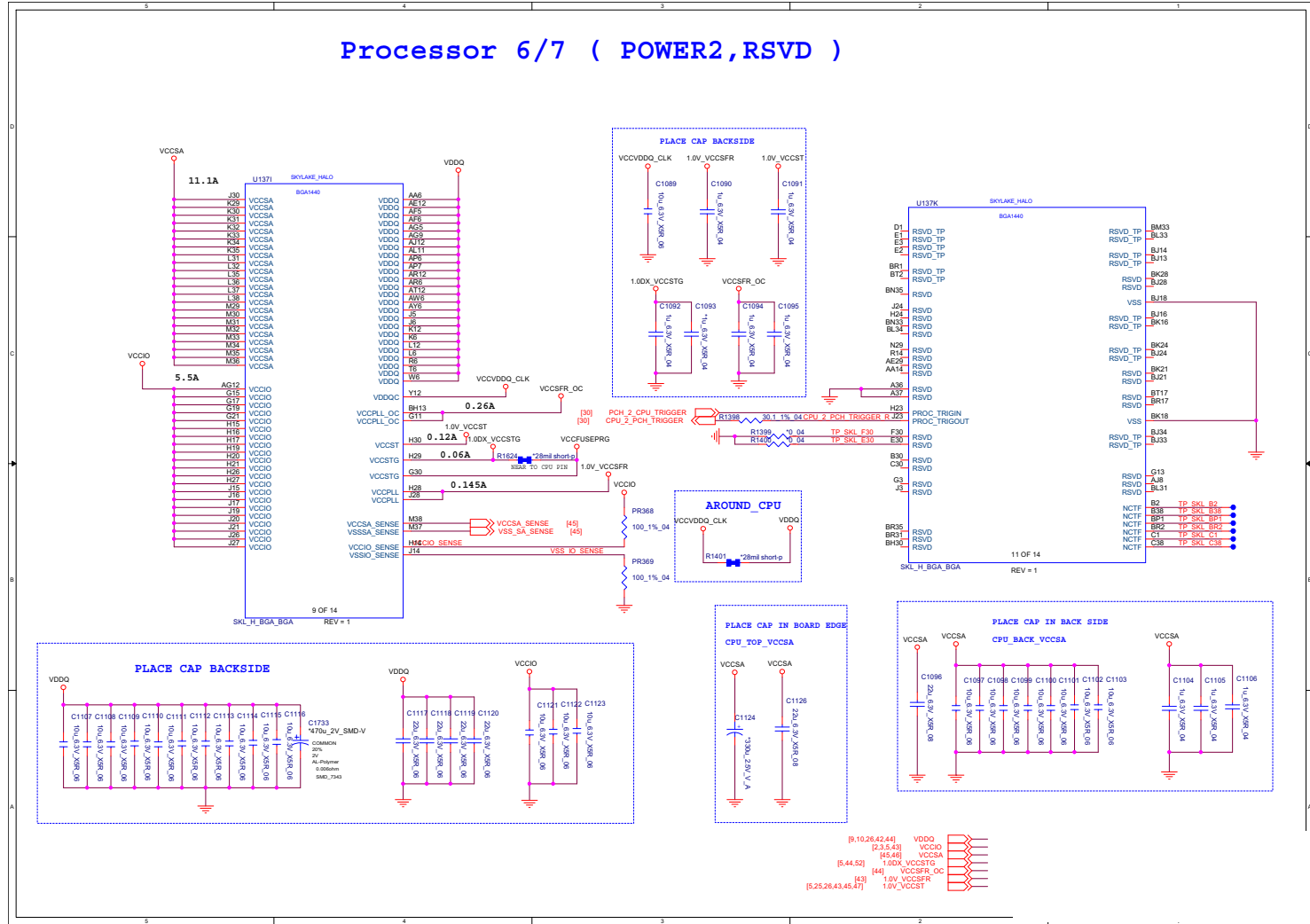

# Processor 7/7

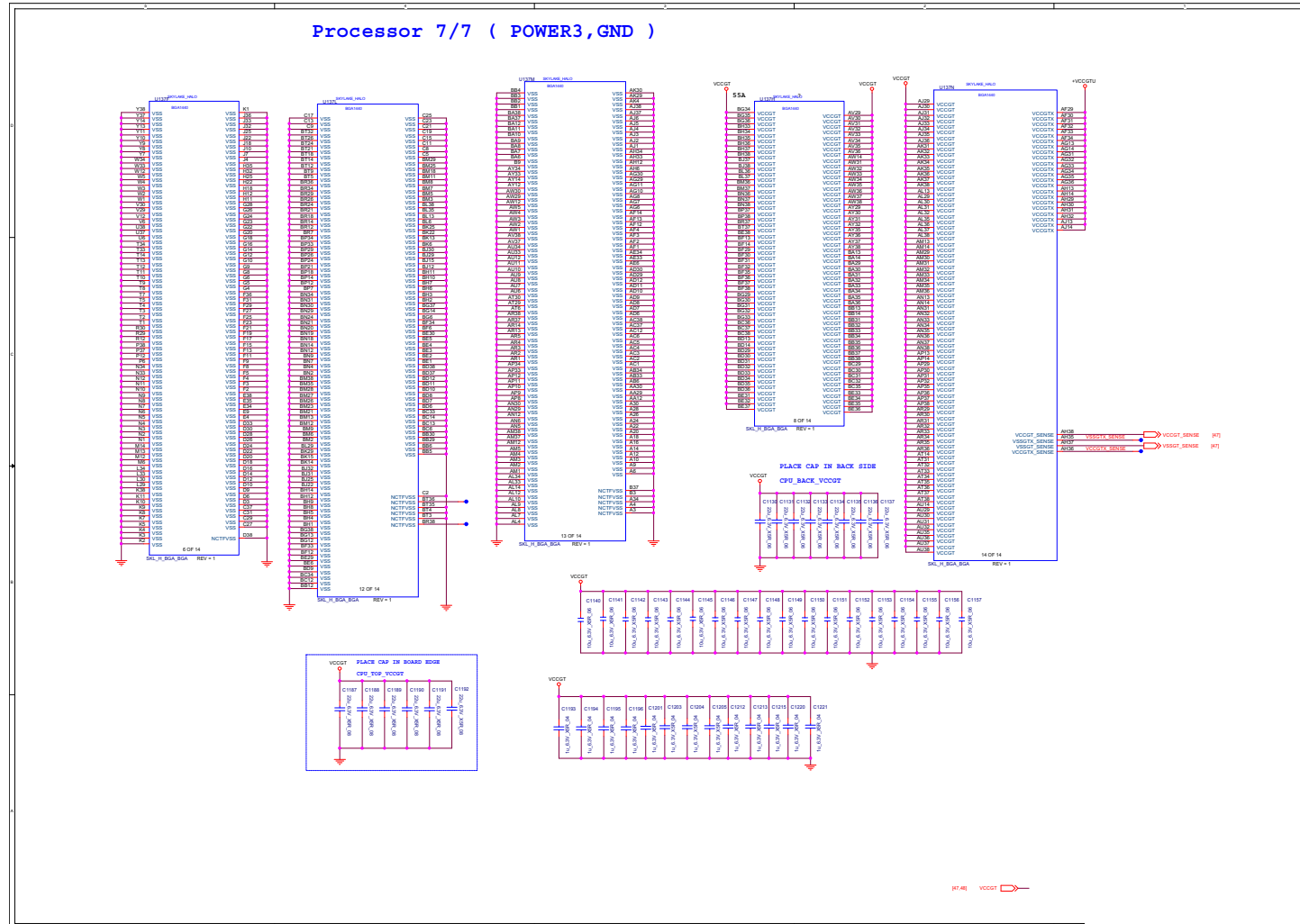

Sheet 8 of 62  
Processor 7/7

B.Schematic Diagrams

# DDR3 SO-DIMM A\_0

Sheet 9 of 62  
DDR3 SO-DIMM  
A\_0

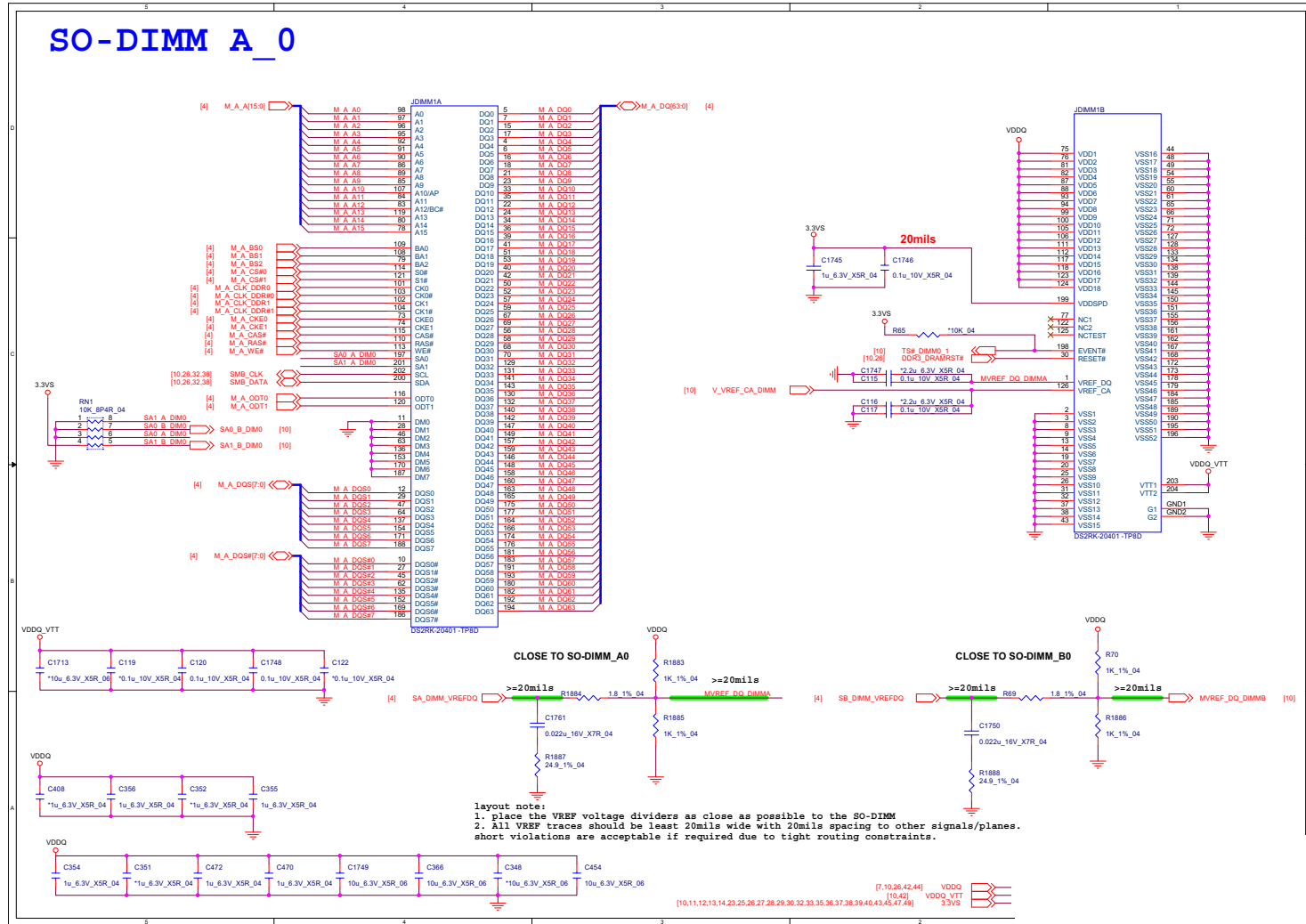

# DDR3 SO-DIMM B\_0

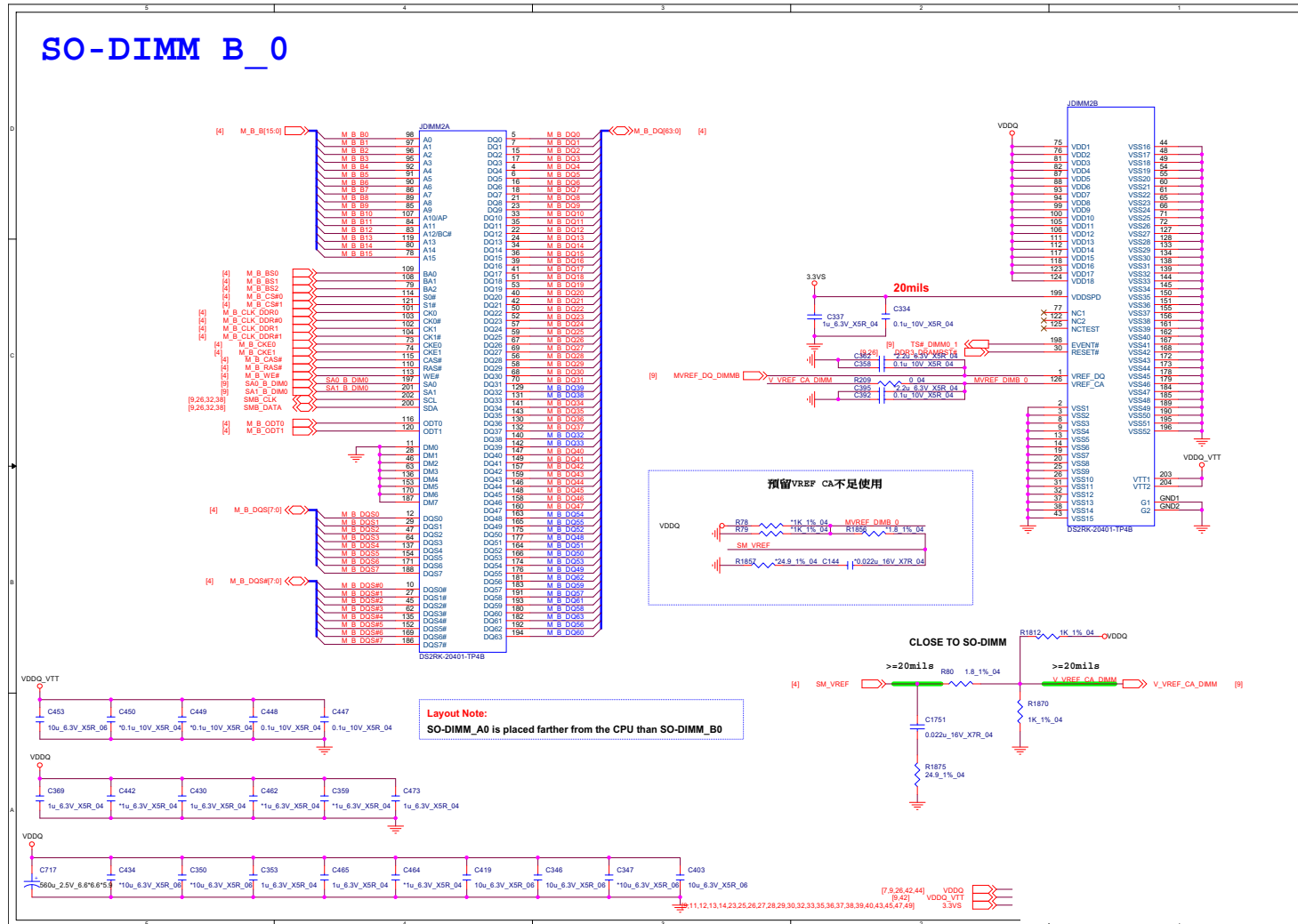

Sheet 10 of 62  
DDR3 SO-DIMM  
B\_0

B.Schematic Diagrams

# PS8625

Sheet 11 of 62  
PS8625

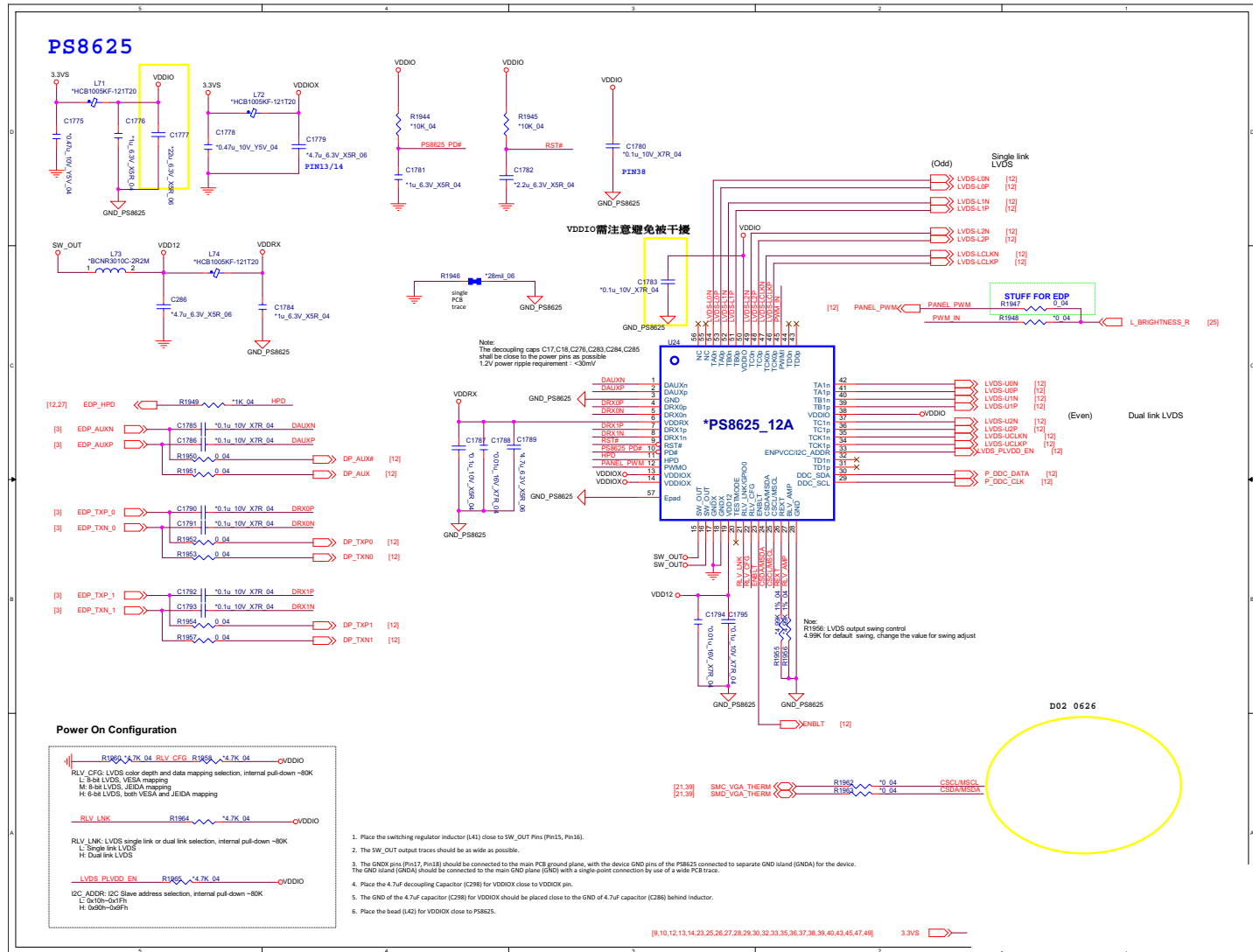



# Panel, BKL Control

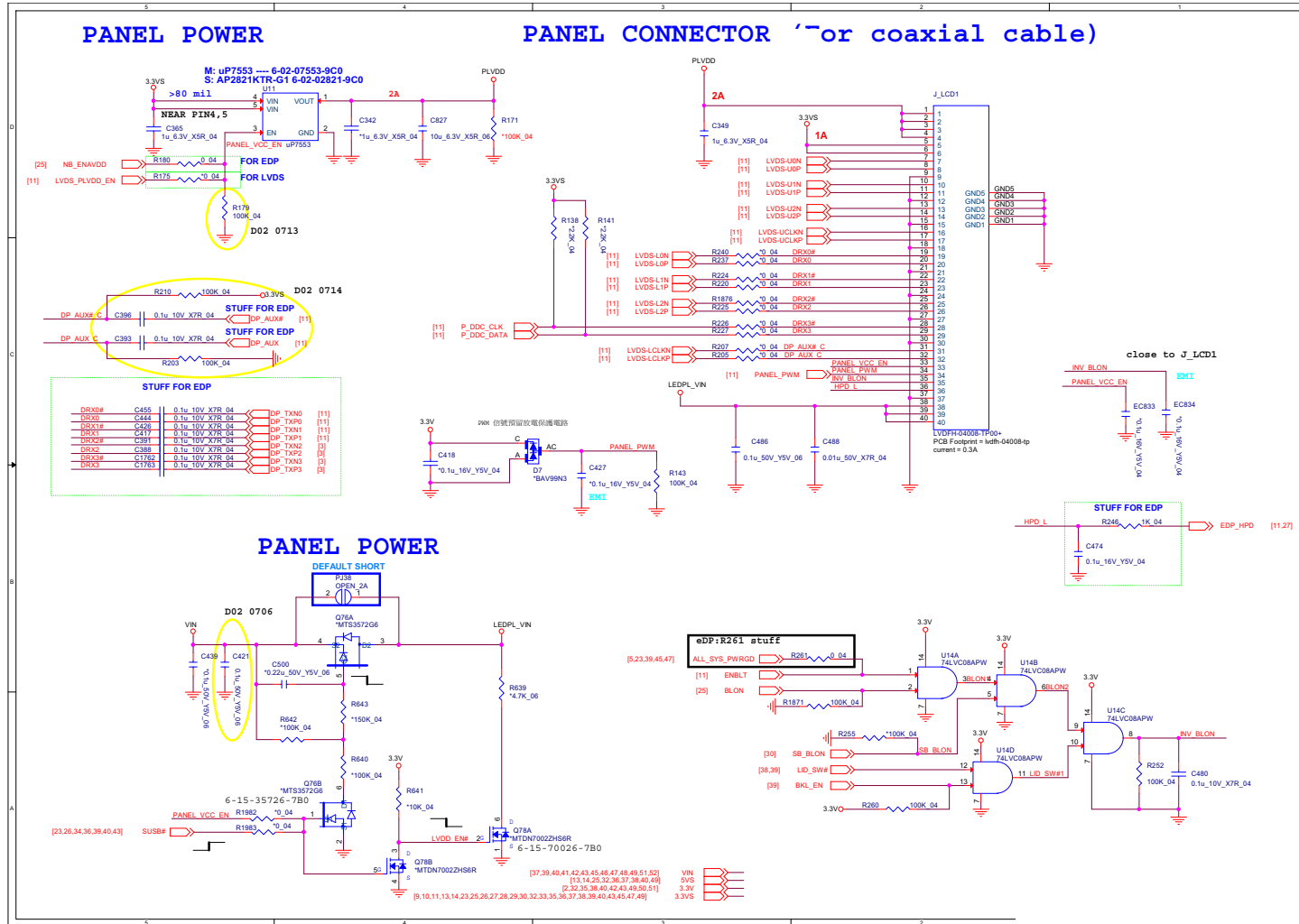

Sheet 12 of 62  
Panel, BKL Control

B.Schematic Diagrams

Schematic Diagrams

RTD2168

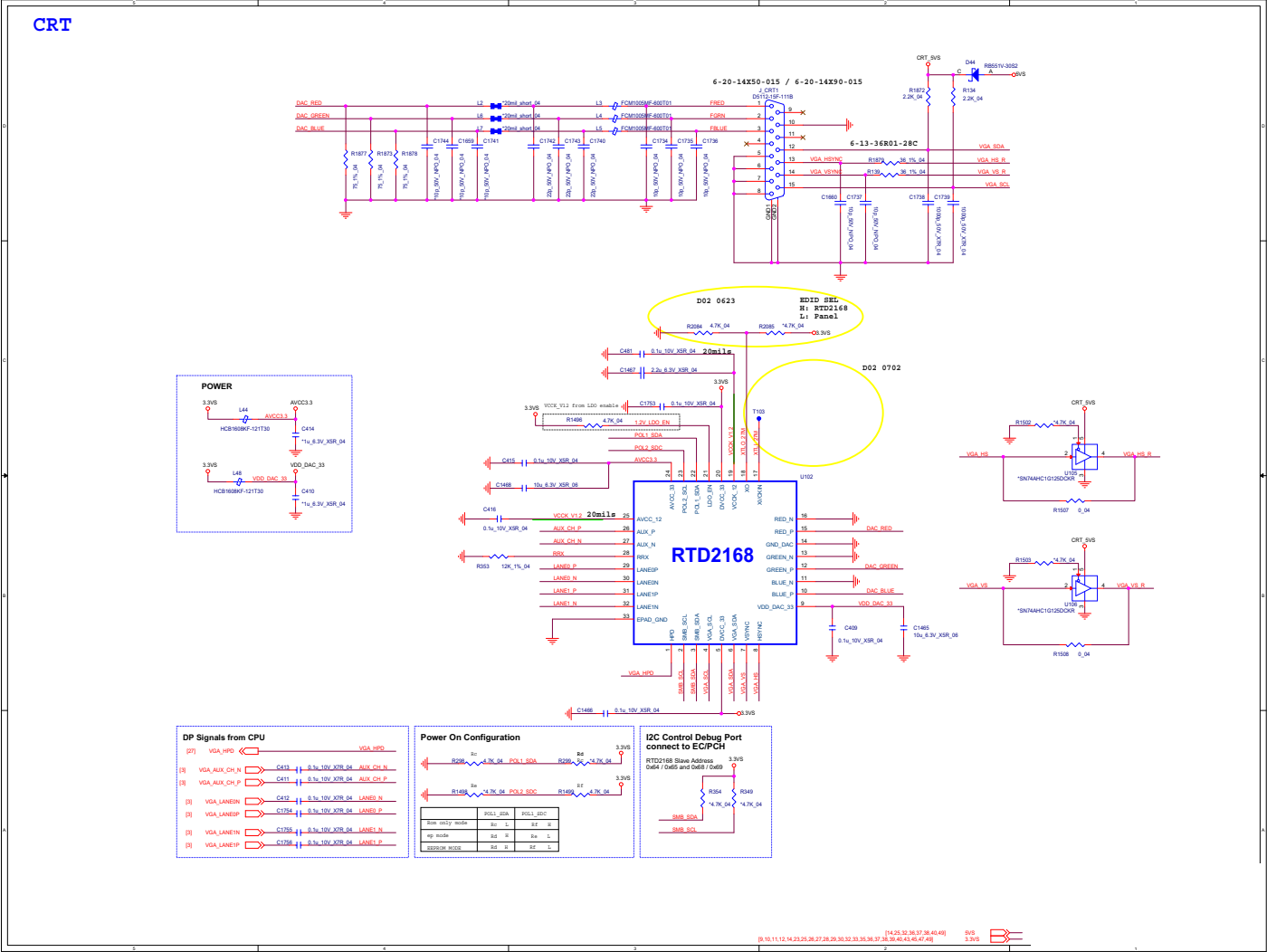

Sheet 13 of 62  
RTD2168

B.Schematic Diagrams

# Mini DP Port



Sheet 14 of 62  
Mini DP Port



# VGA Frame Buffer A

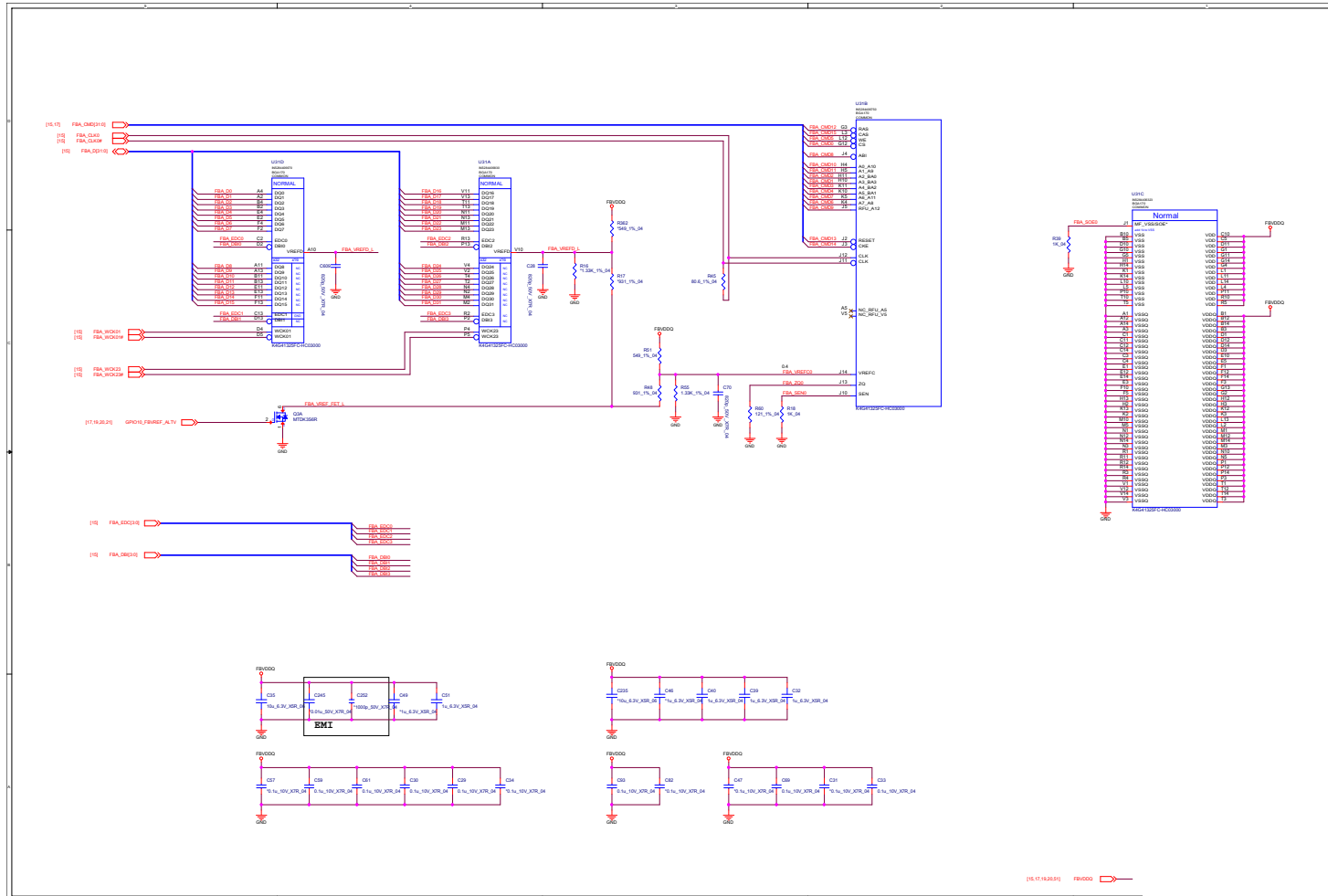

Sheet 16 of 62  
VGA Frame Buffer  
A

# VGA Frame Buffer A

Sheet 17 of 62  
VGA Frame Buffer  
A

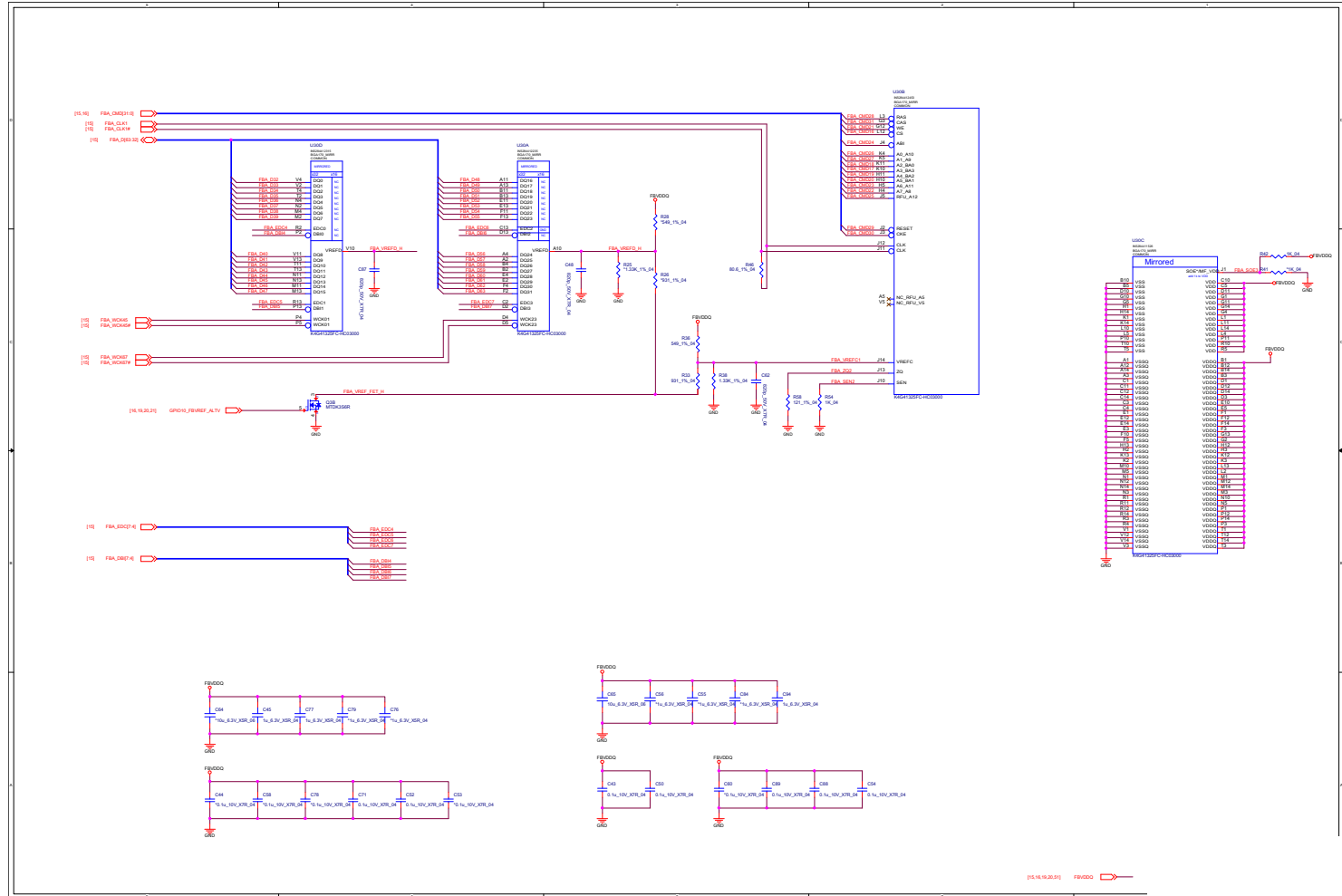



# VGA PCI-E Interface

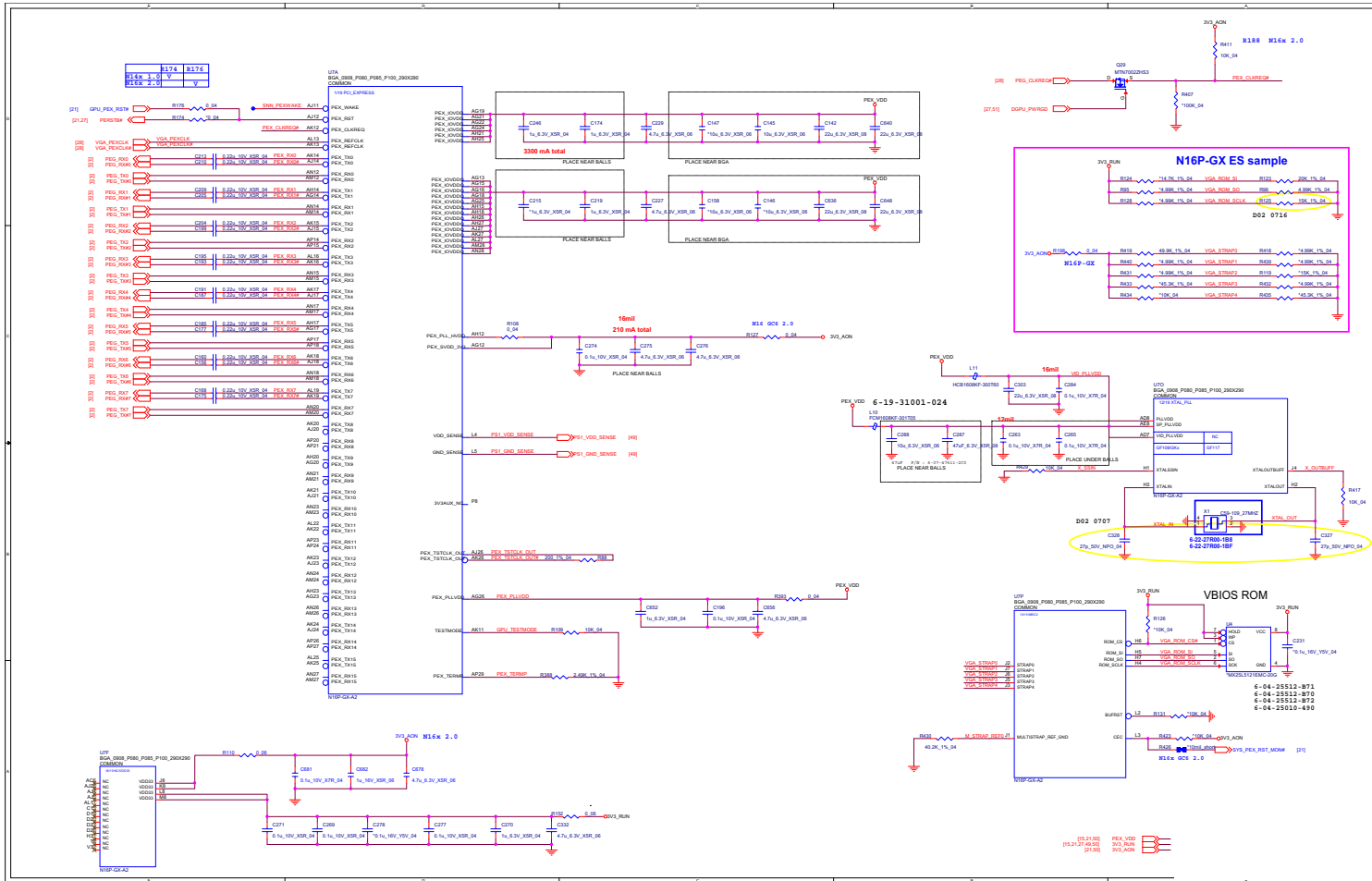

Sheet 18 of 62  
VGA PCI-E  
Interface

B.Schematic Diagrams

# VGA Frame Buffer B

Sheet 19 of 62  
VGA Frame Buffer  
B

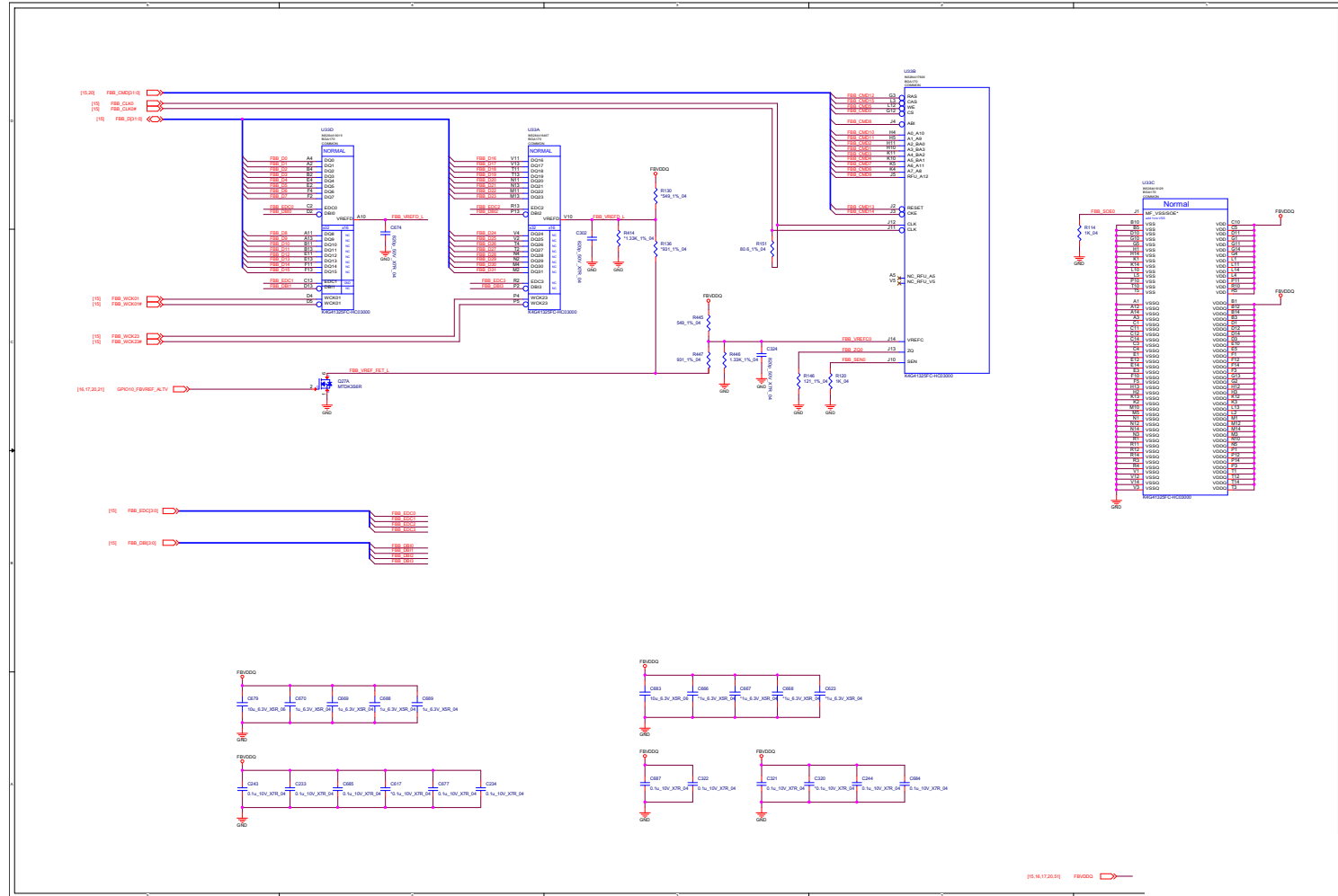

# VGA Frame Buffer B

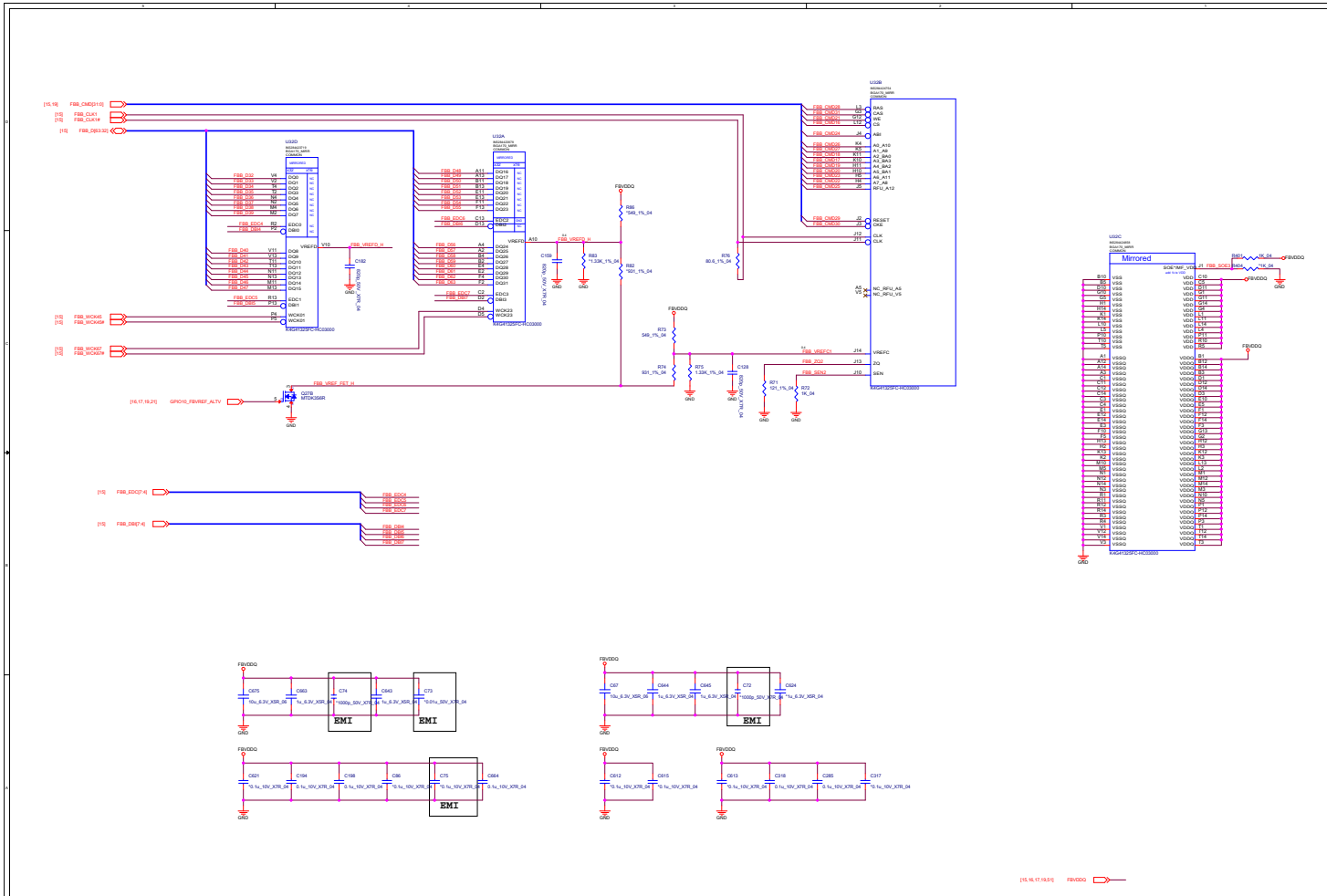

Sheet 20 of 62  
VGA Frame Buffer  
B

B.Schematic Diagrams

VGA I/O

Sheet 21 of 62  
VGA I/O

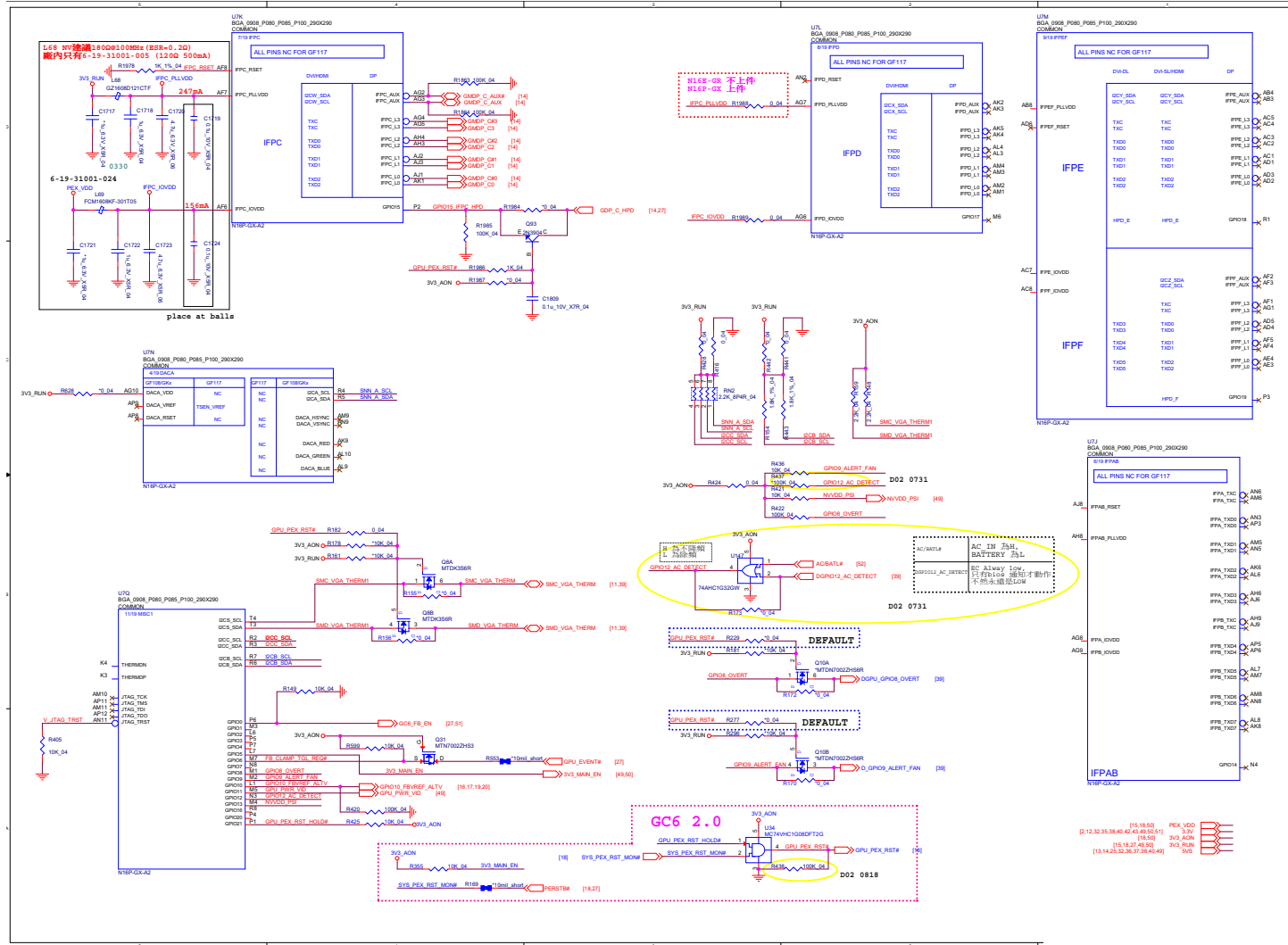

# VGA NVVDD Decoupling

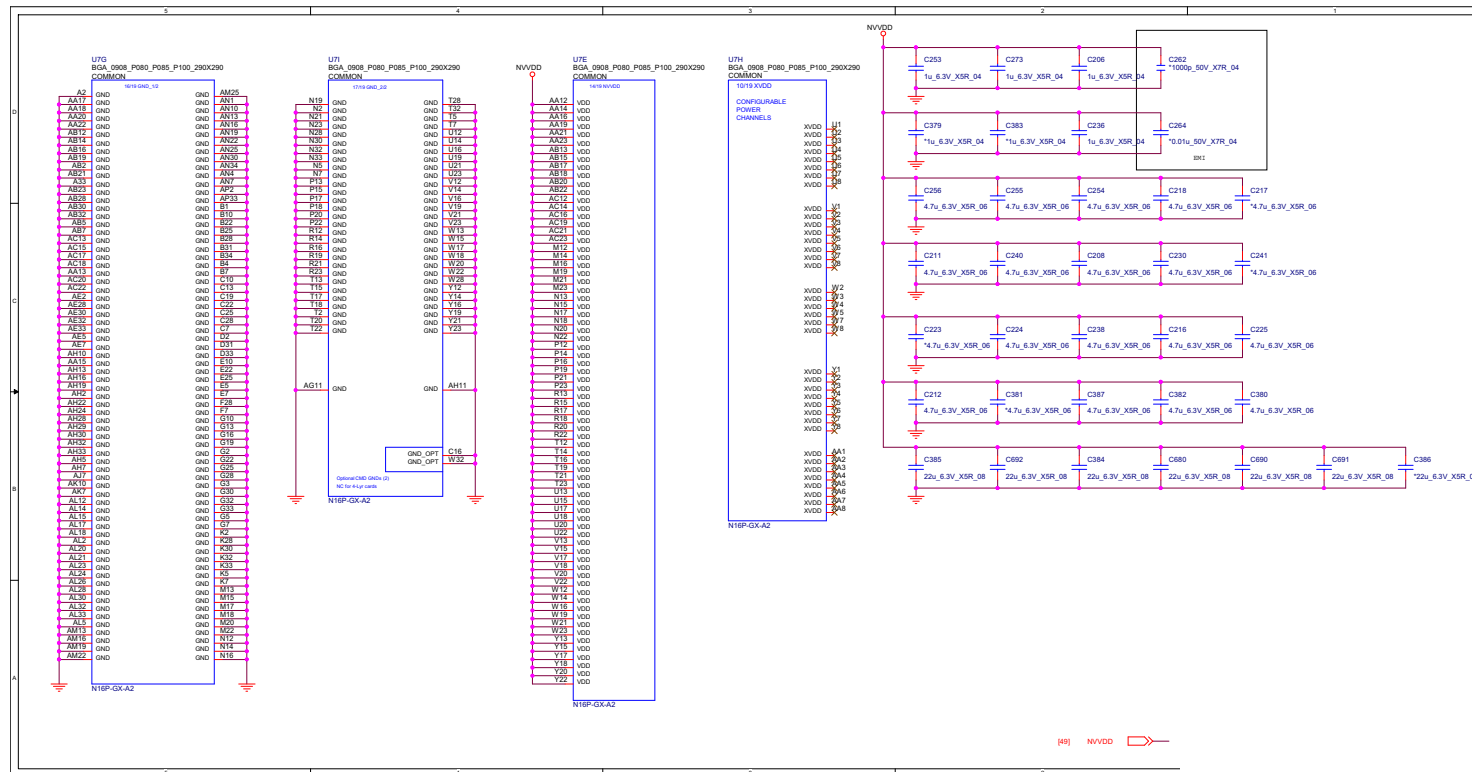

Sheet 22 of 62  
VGA NVVDD  
Decoupling

B.Schematic Diagrams

# PCH 1/9

Sheet 23 of 62  
PCH 1/9

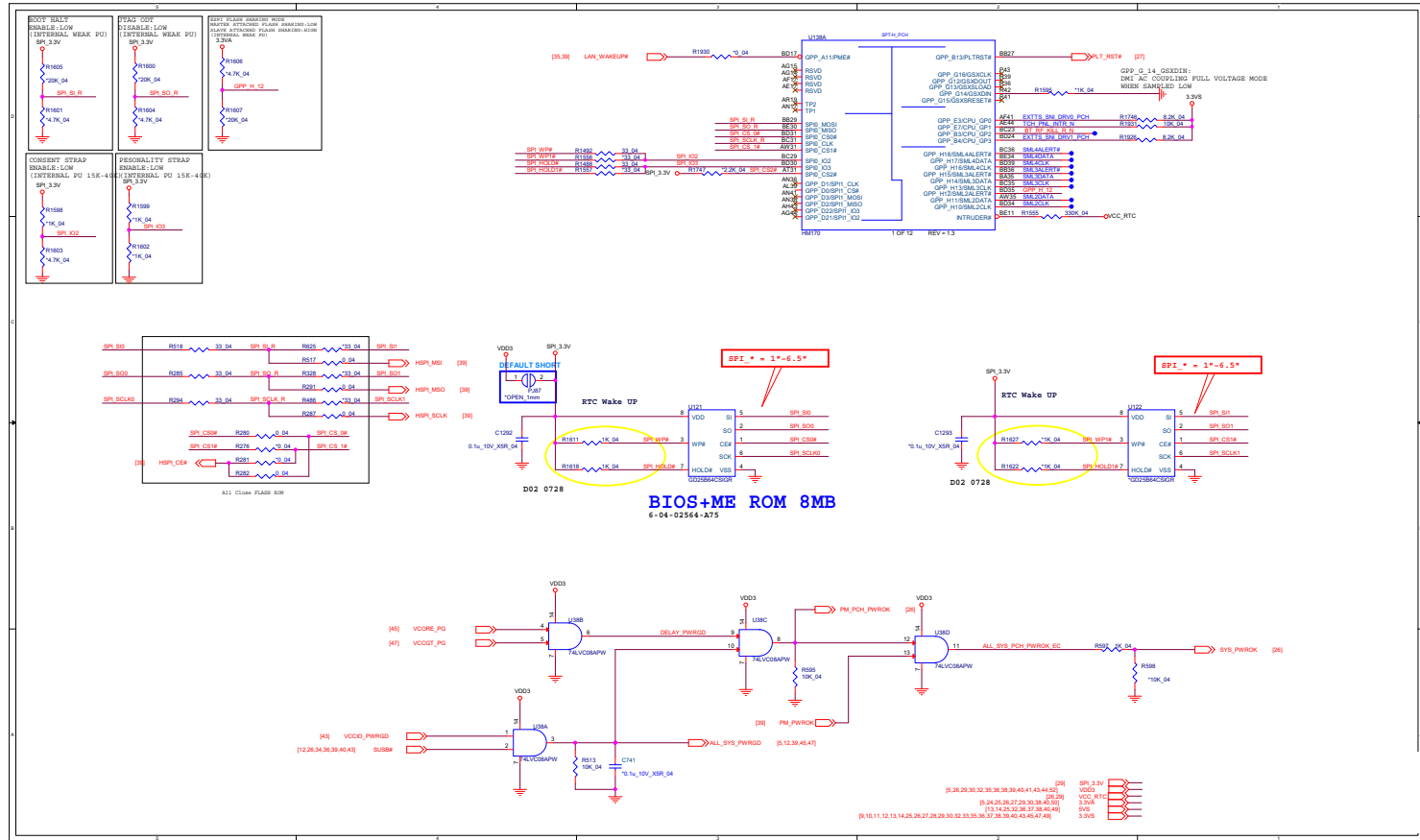

PCH 2/9

Sheet 24 of 62  
PCH 2/9

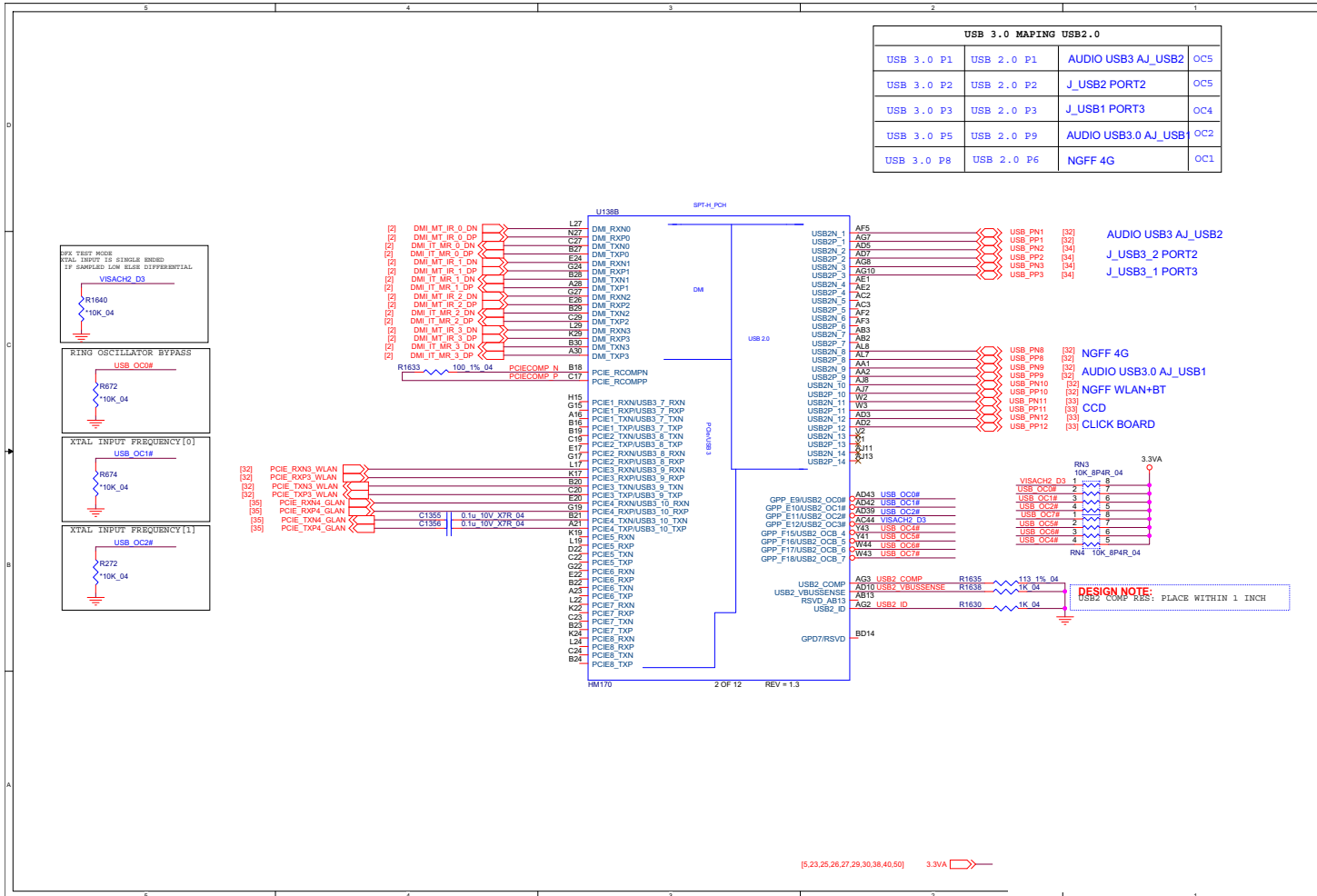



# PCH 3/9

Sheet 25 of 62  
PCH 3/9

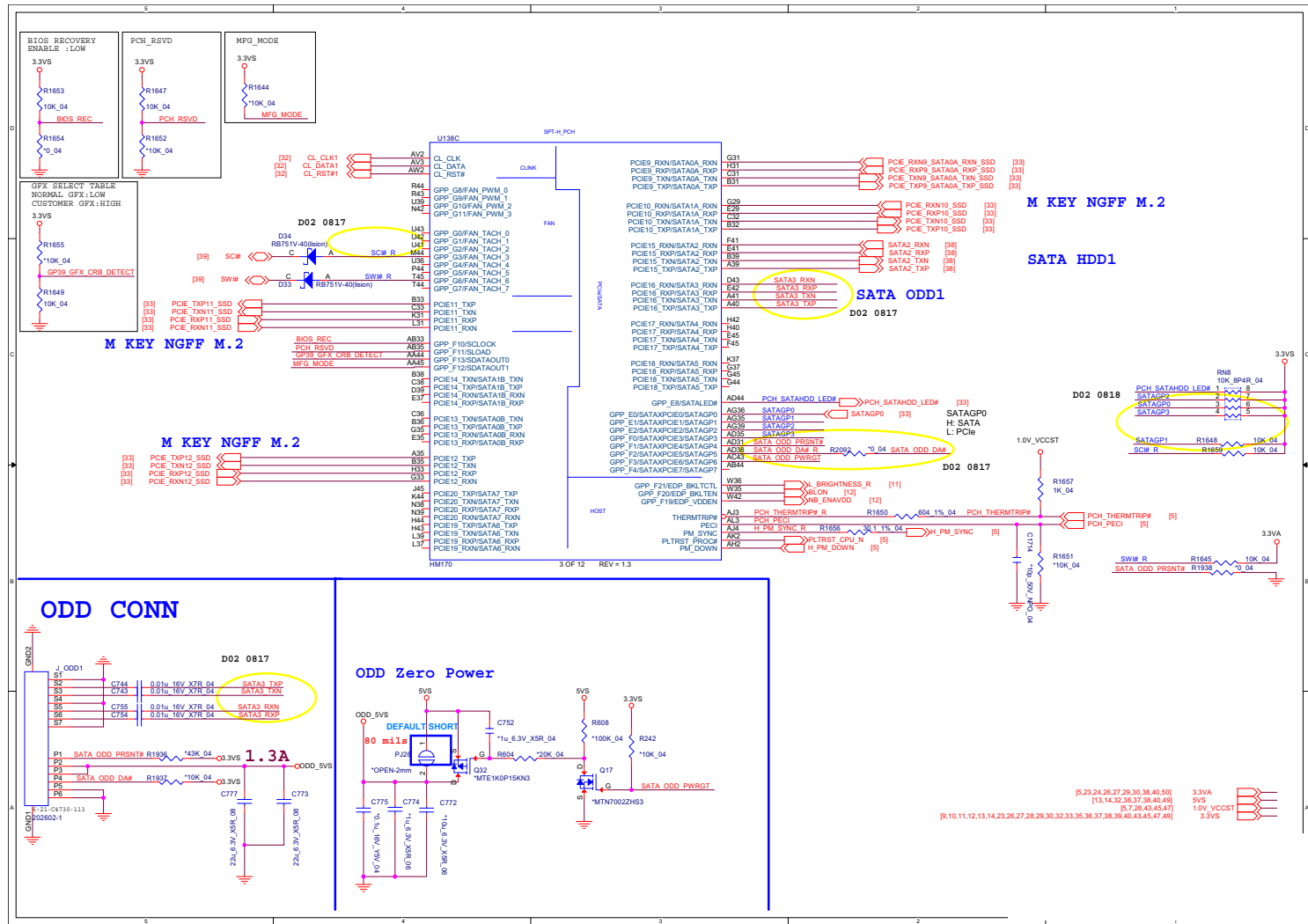

PCH 4/9

Sheet 26 of 62  
PCH 4/9

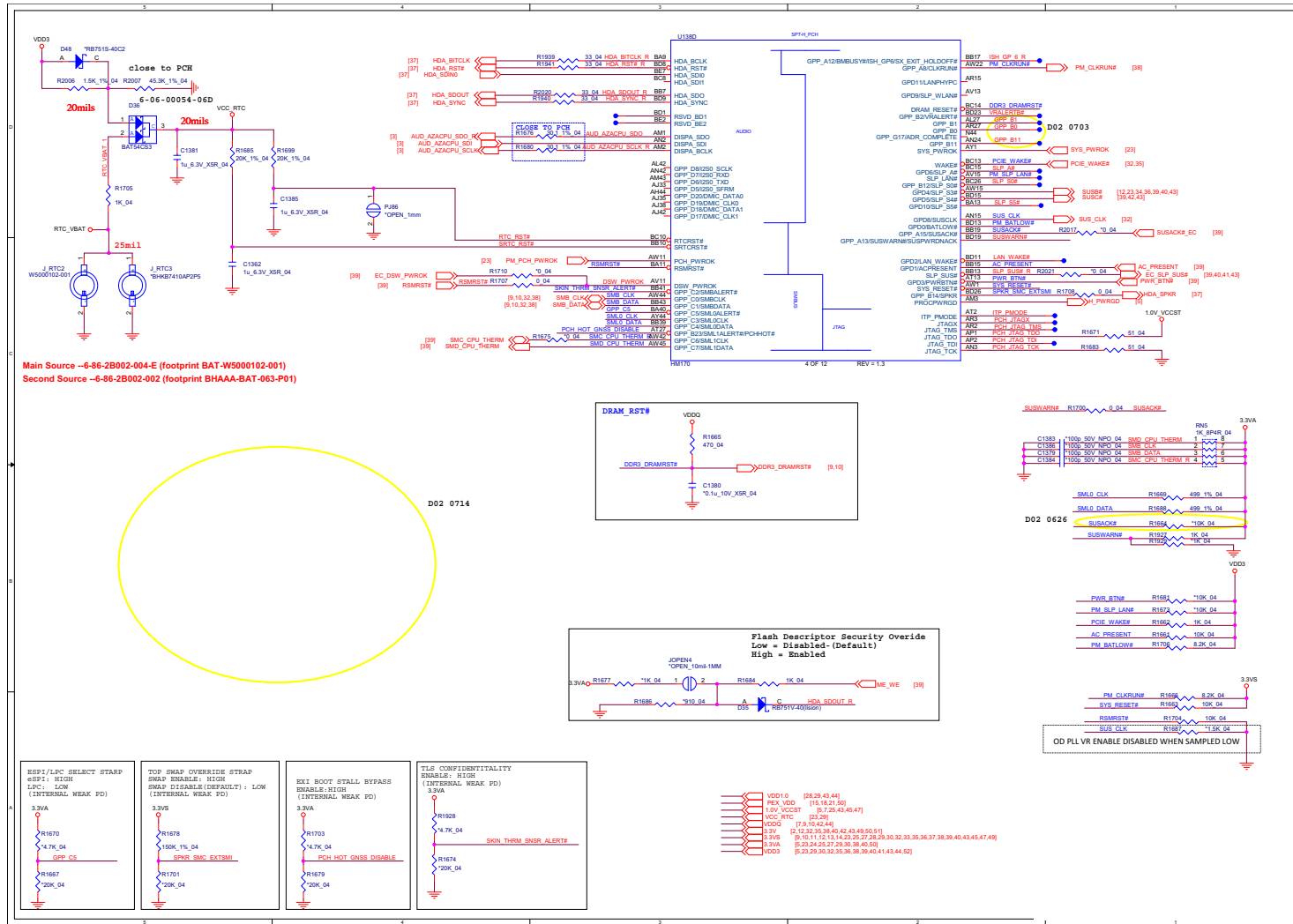

# PCH 5/9

Sheet 27 of 62  
PCH 5/9

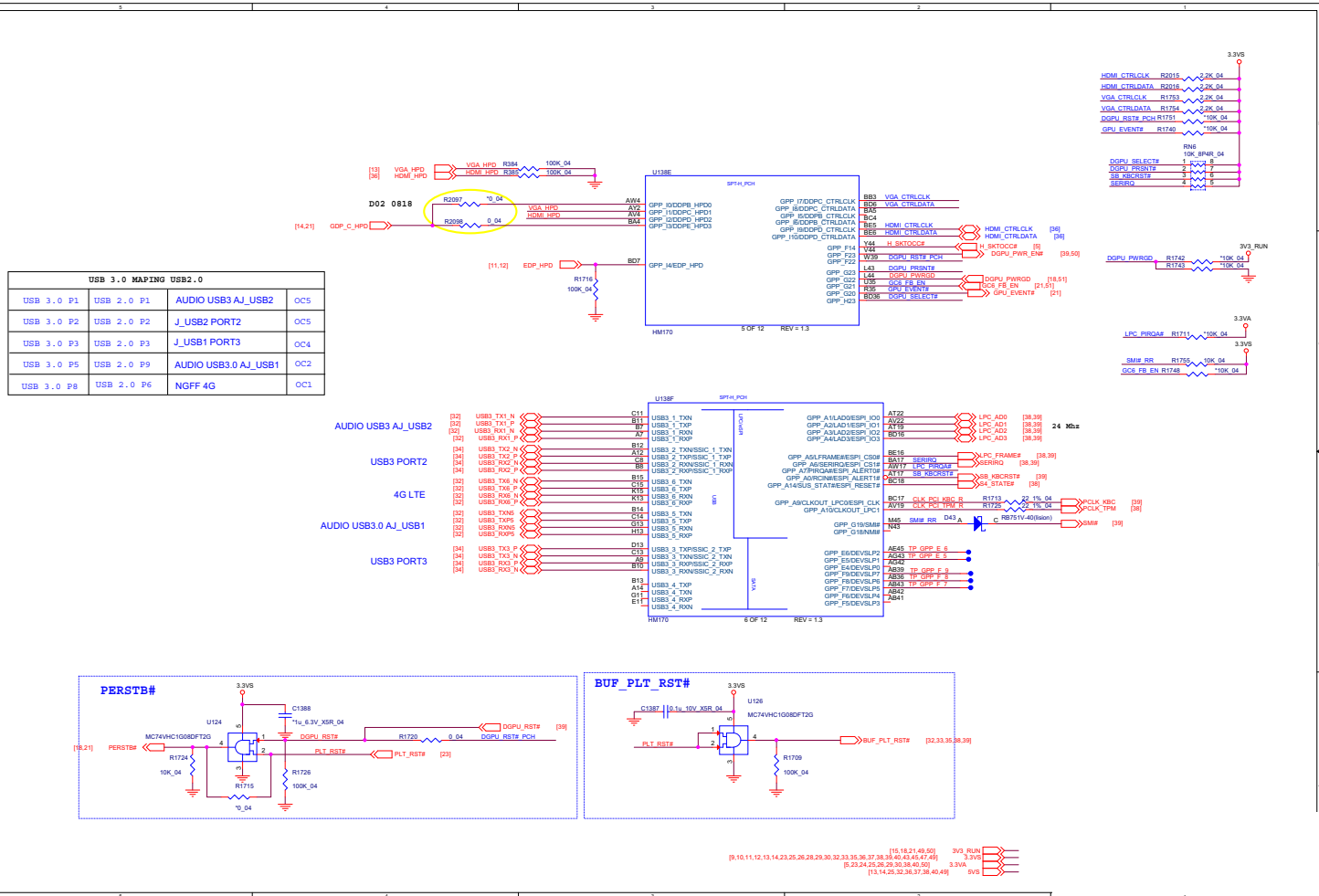

# PCH 6/9

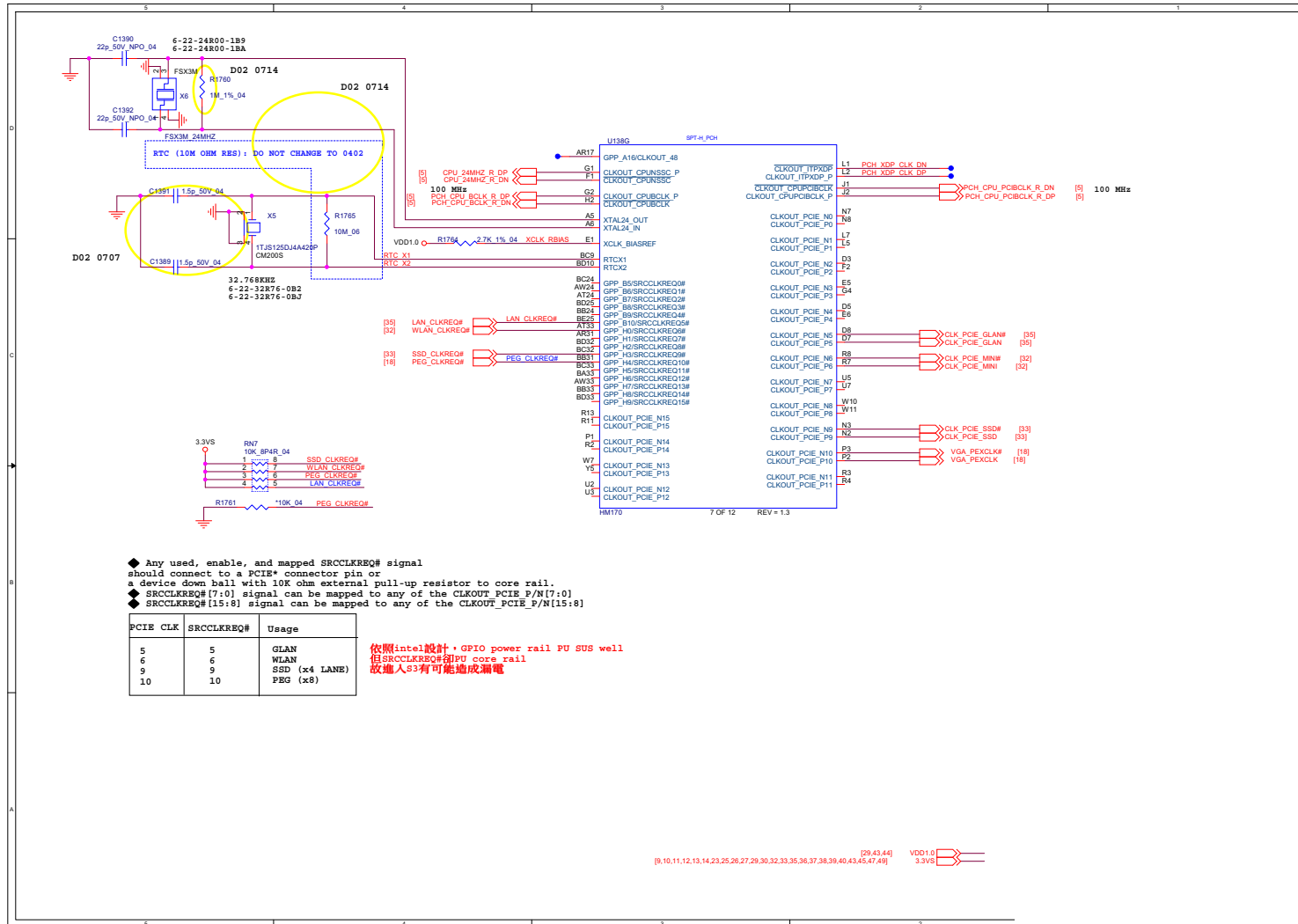

B.Schematic Diagrams

Sheet 28 of 62  
PCH 6/9



# PCH 8/9

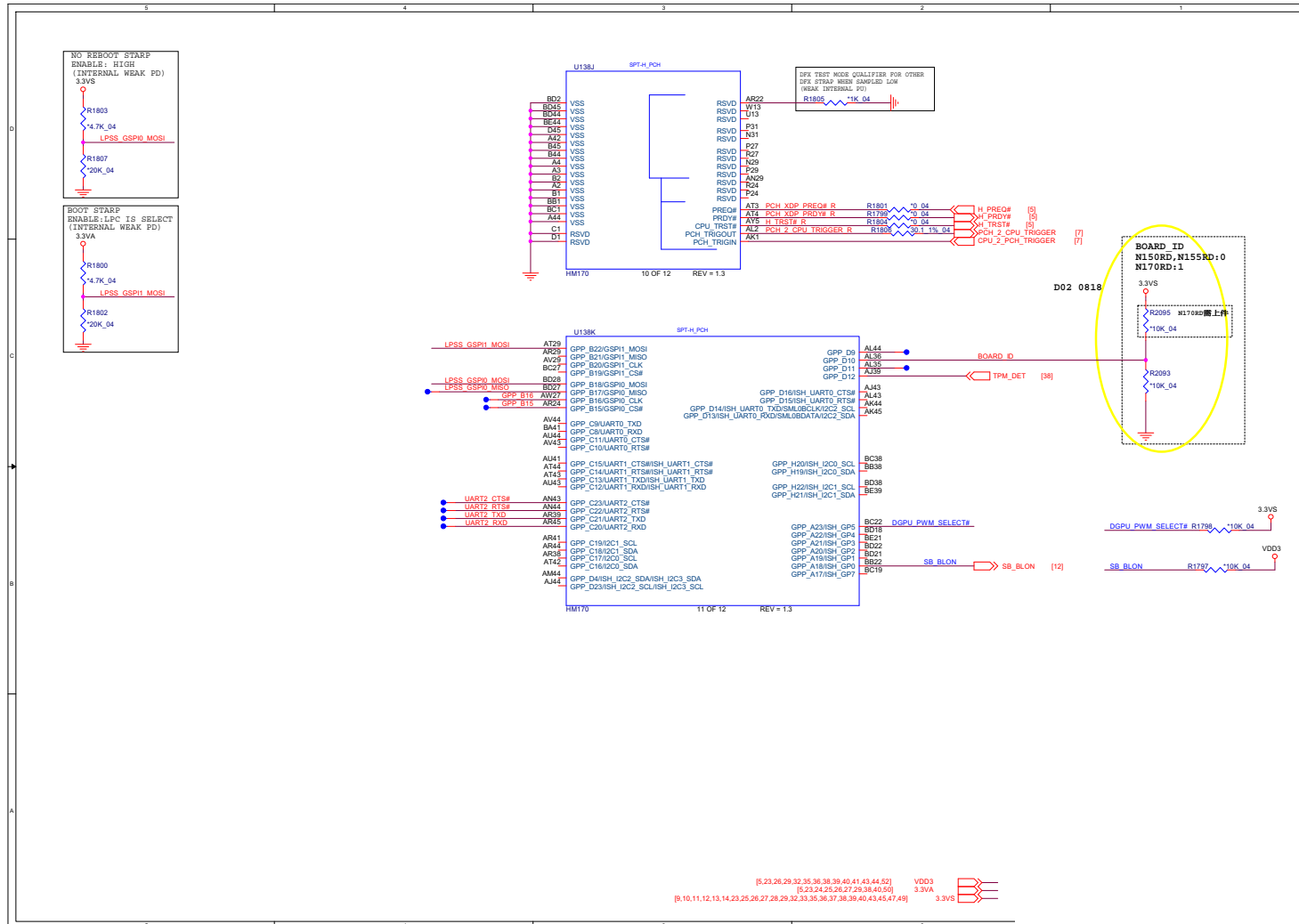

Sheet 30 of 62  
PCH 8/9

B. Schematic Diagrams

# PCH 9/9

Sheet 31 of 62  
PCH 9/9

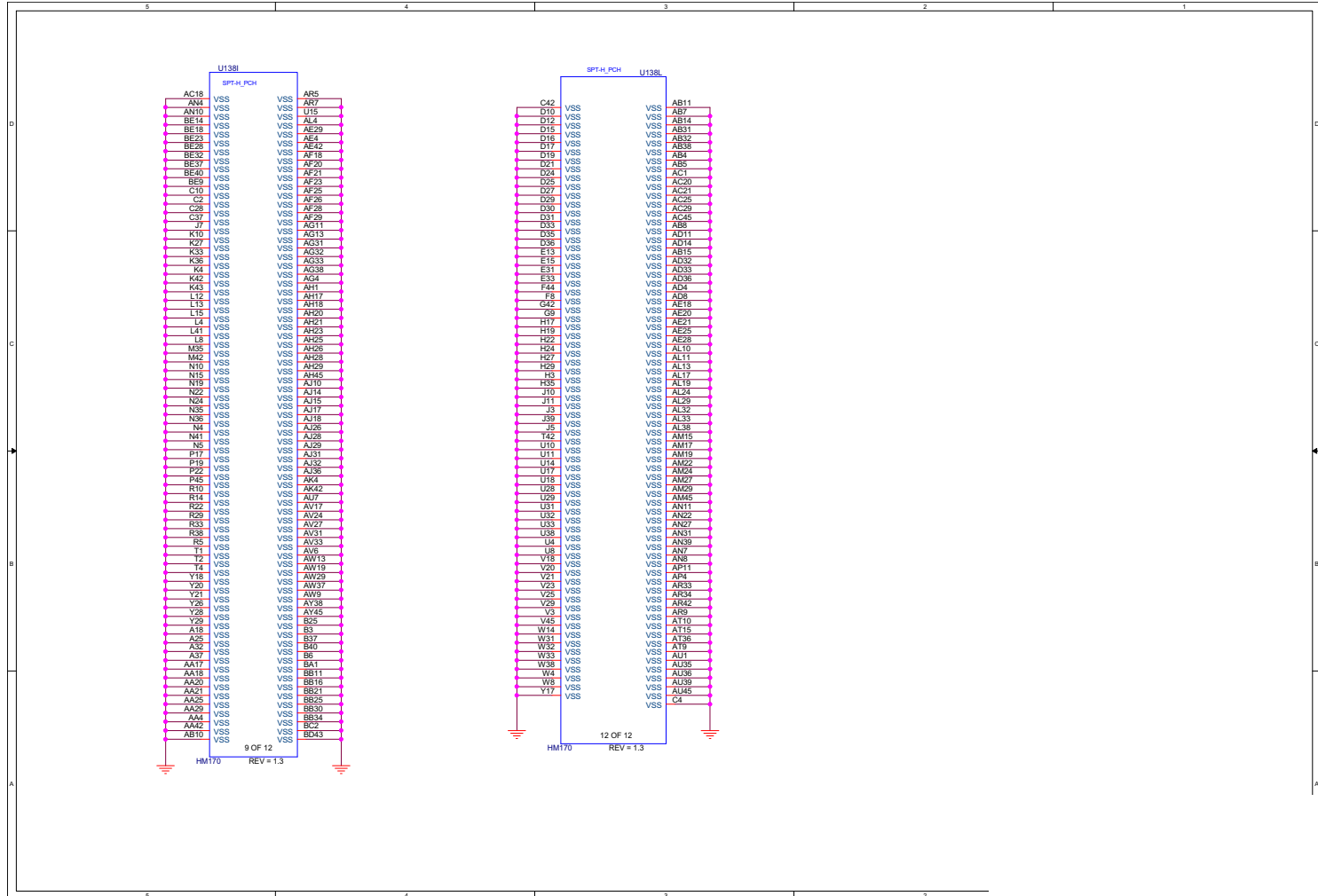



# WLAN, 4G, Fan, Audio Con

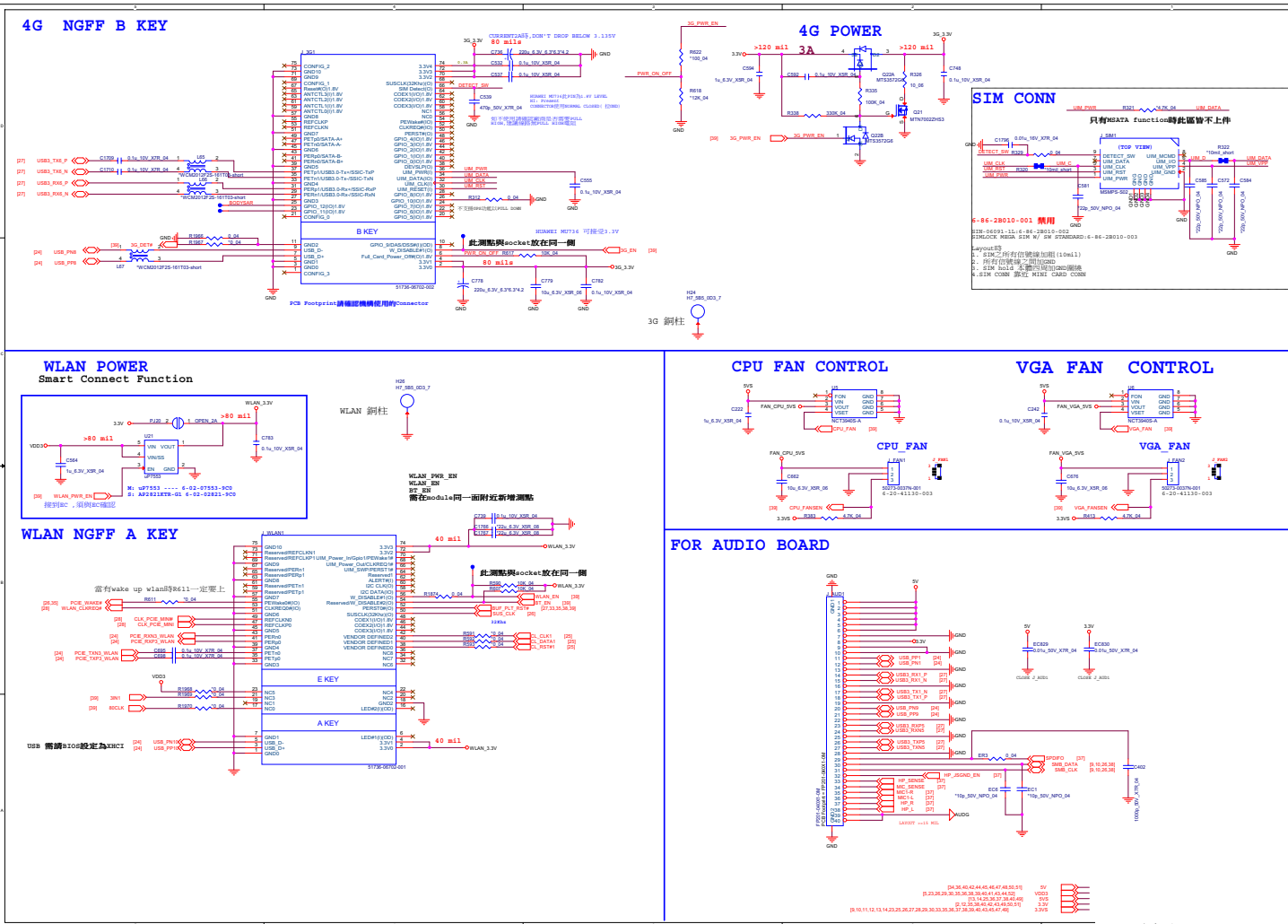

Sheet 32 of 62  
WLAN, 4G, Fan,  
Audio Con

# CCD, M-Key, Click Conn

Sheet 33 of 62  
 CCD, M-Key,  
 Click Conn

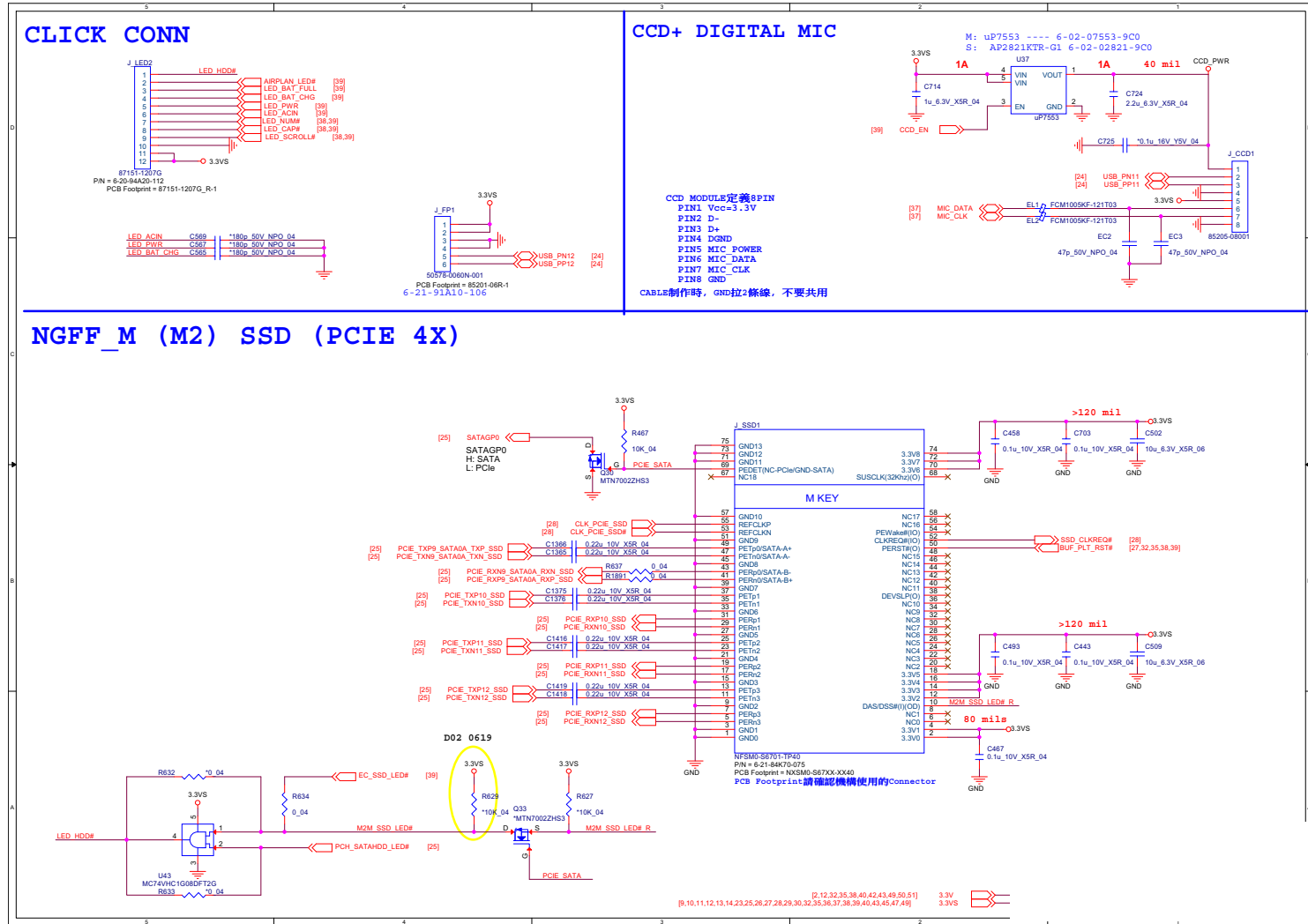

# USB 3.0, USB Charger

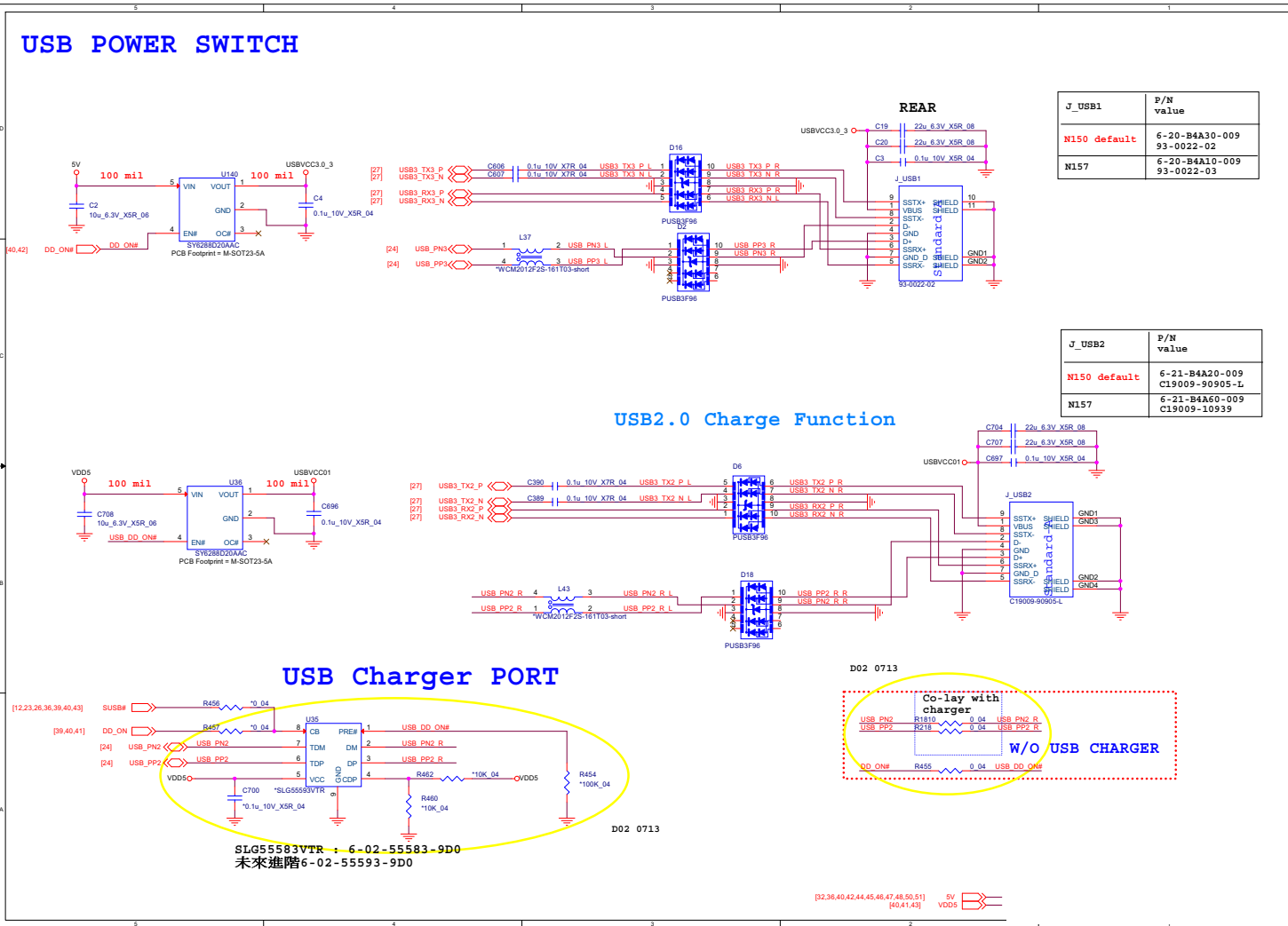

Sheet 34 of 62  
USB 3.0,  
USB Charger

B.Schematic Diagrams

# LAN RTL8411B, Card Reader

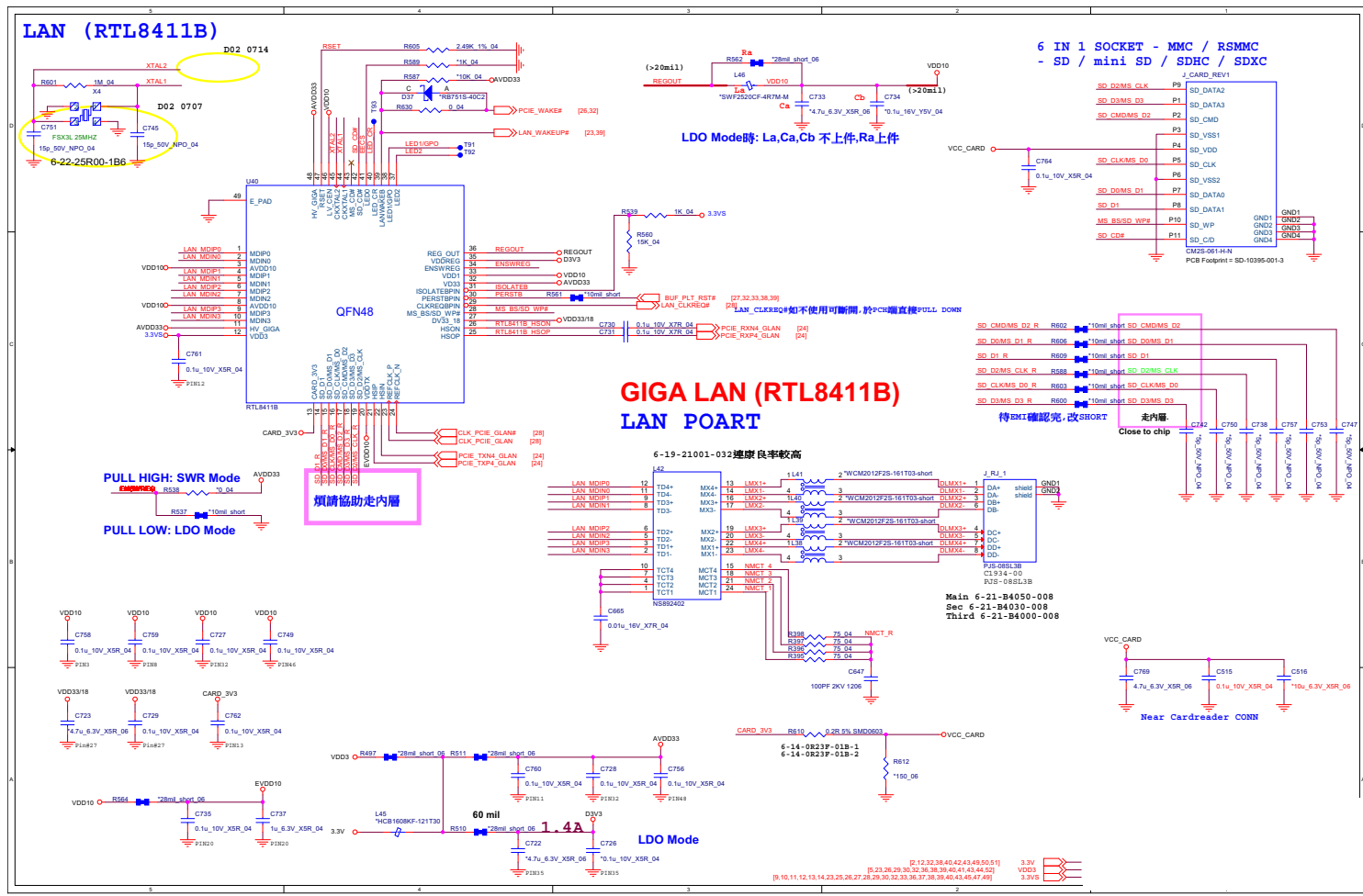

Sheet 35 of 62  
LAN RTL8411B,  
Card Reader

B.Schematic Diagrams

# HDMI, PS8407A

## HDMI CONNECTOR ( W/ HDMI Repeater)

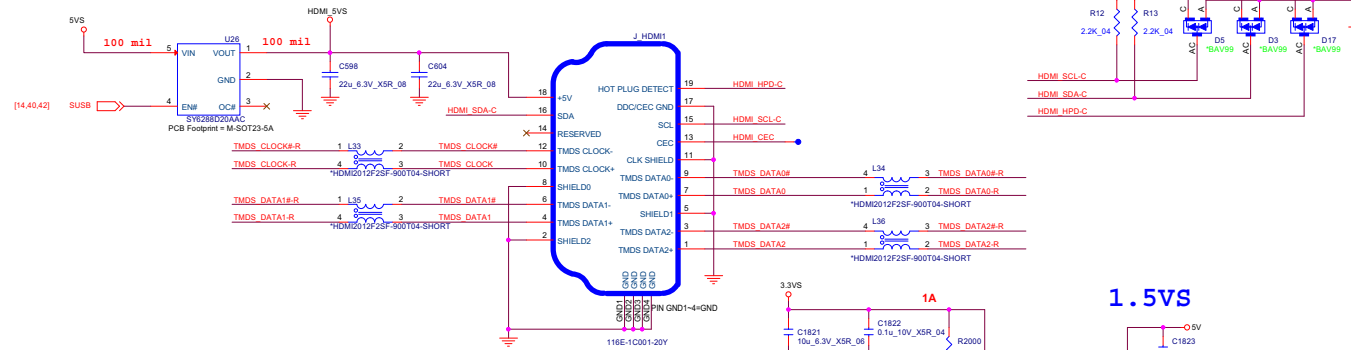

## HDMI Repeater

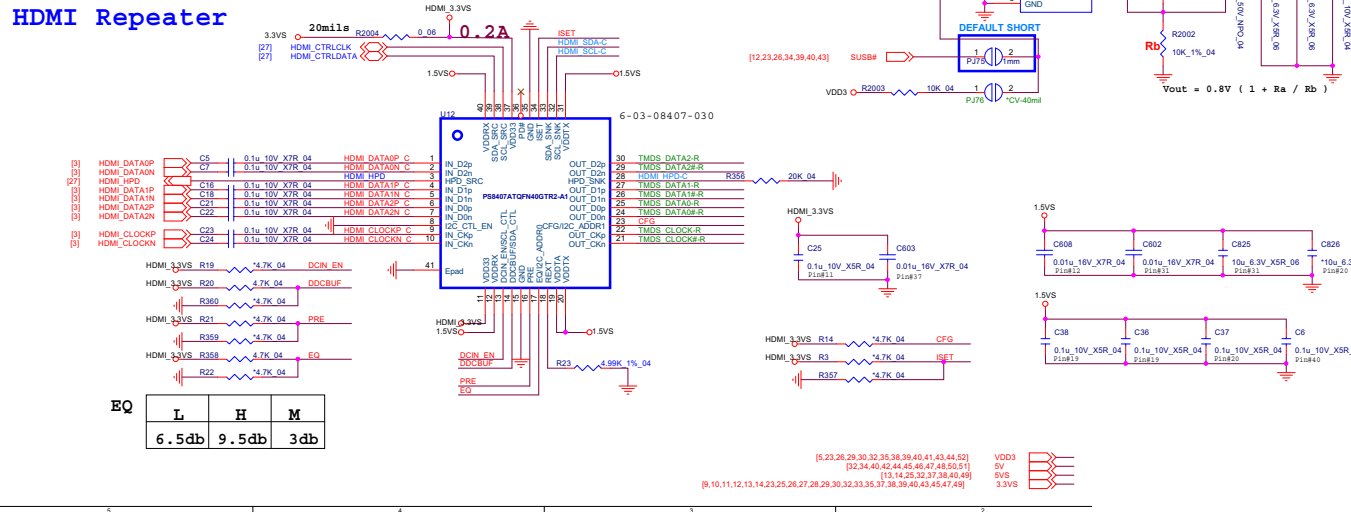

EQ

L	H	M
6.5db	9.5db	3db

Sheet 36 of 62  
HDMI, PS8407A

B.Schematic Diagrams

# Audio Codec ALC269

B.Schematic Diagrams

Sheet 37 of 62  
Audio Codec  
ALC269

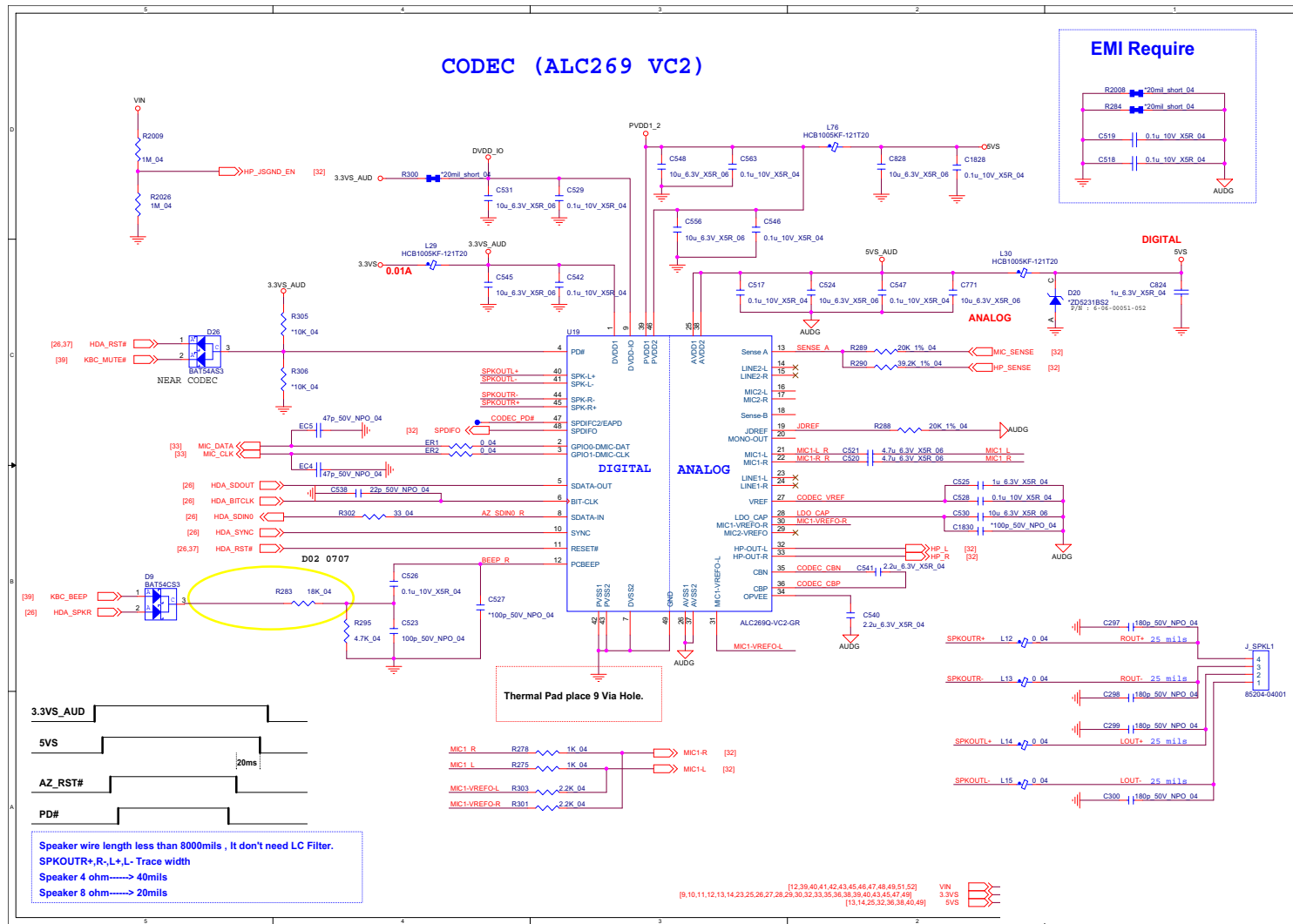

# HDD, TPM, KB LED, PWR Con, T/P

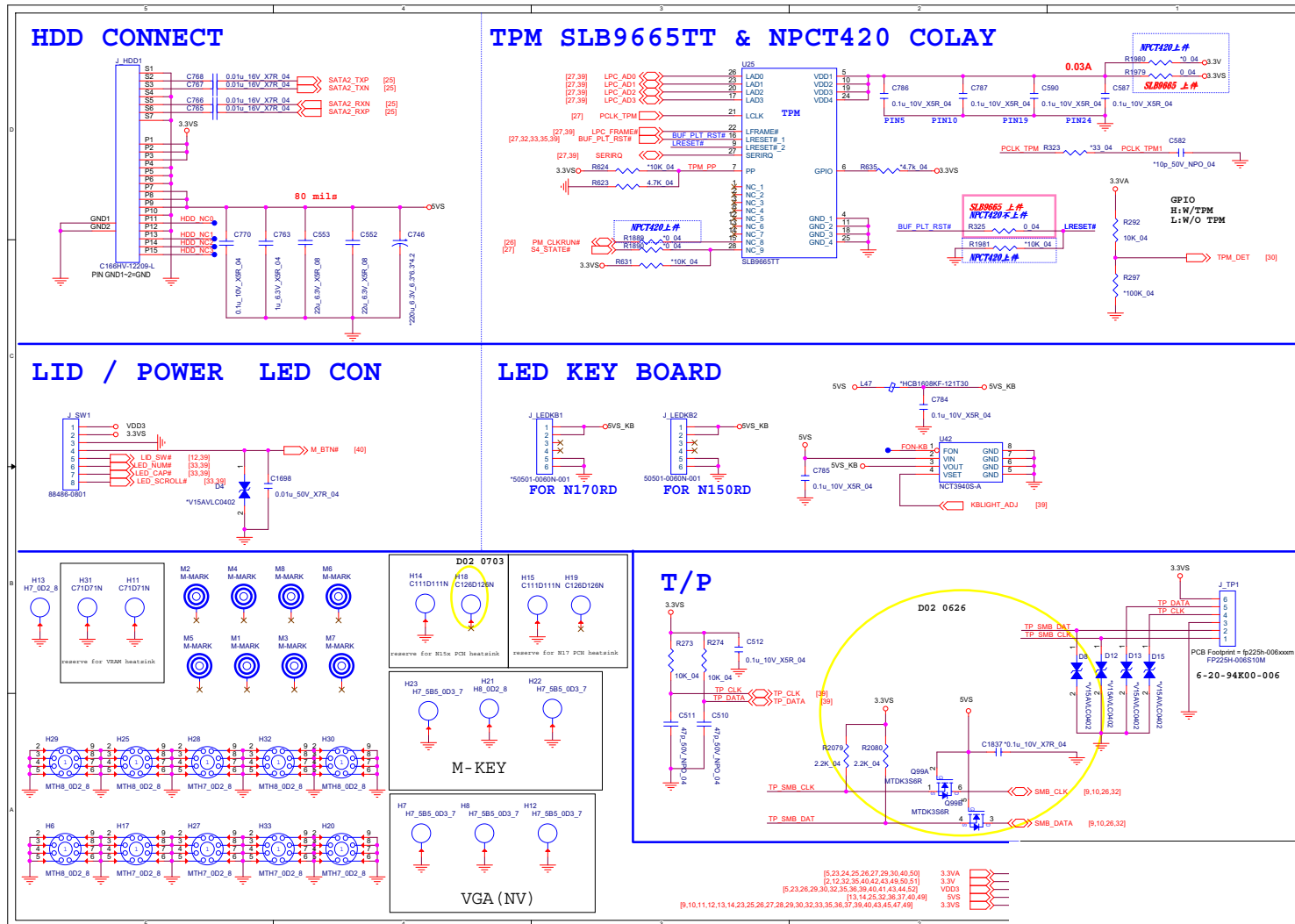

Sheet 38 of 62  
HDD, TPM, KB LED,  
PWR Con, T/P

B.Schematic Diagrams



# KBC-ITE IT8587

Sheet 39 of 62  
KBC-ITE IT8587

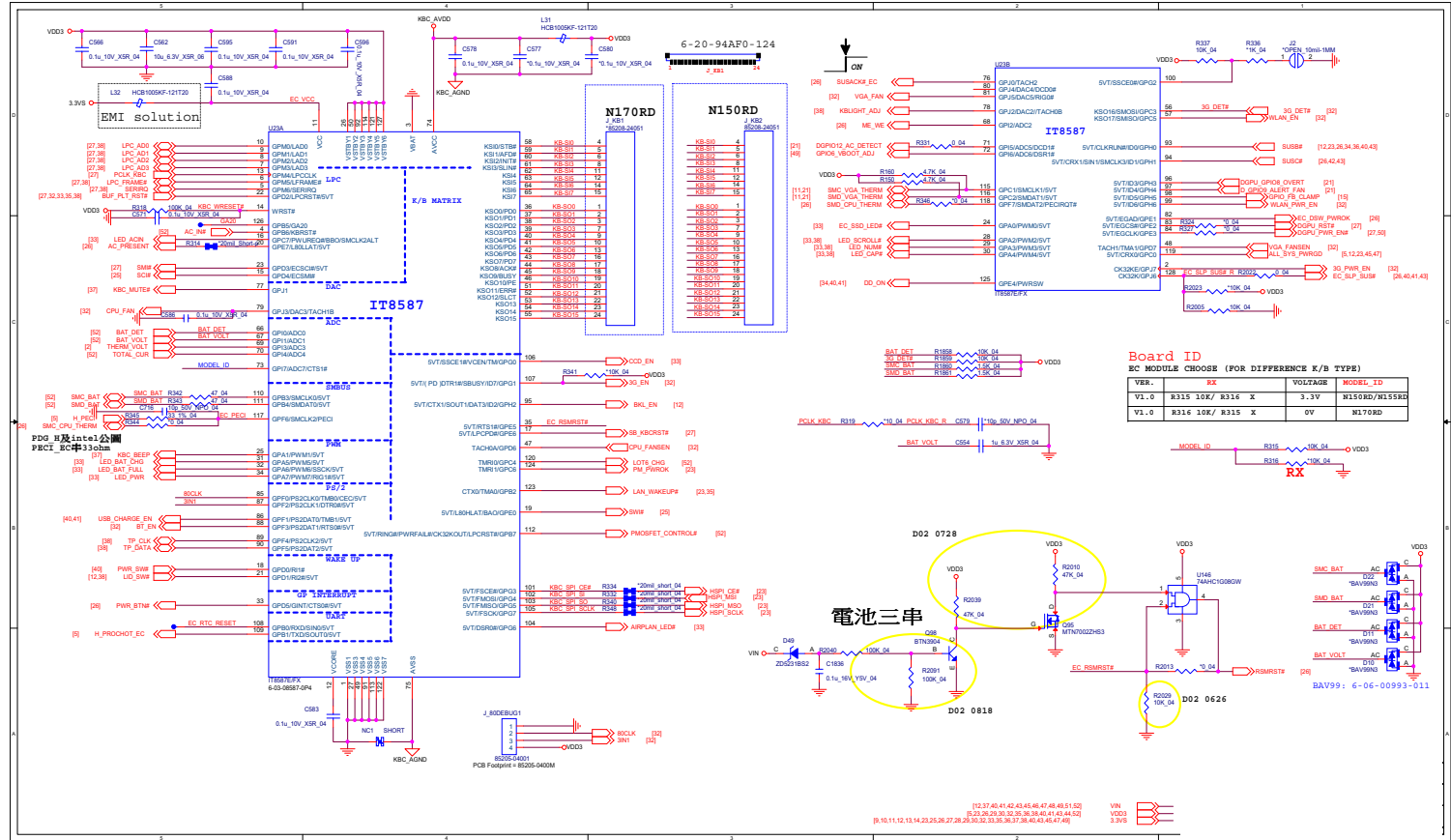

# System Power

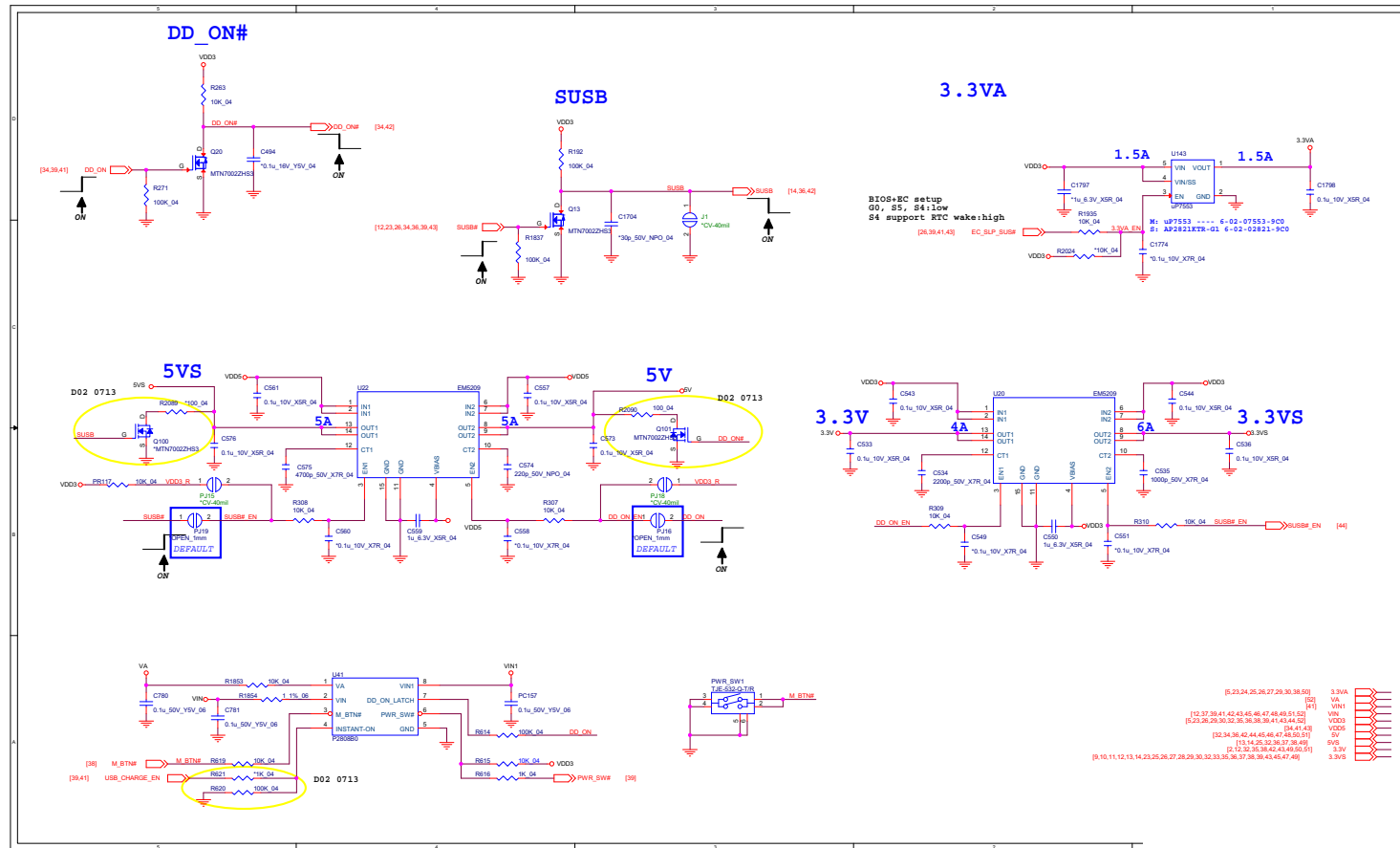

Sheet 40 of 62  
System Power

B.Schematic Diagrams

# VDD3, VDD5

Sheet 41 of 62  
VDD3, VDD5

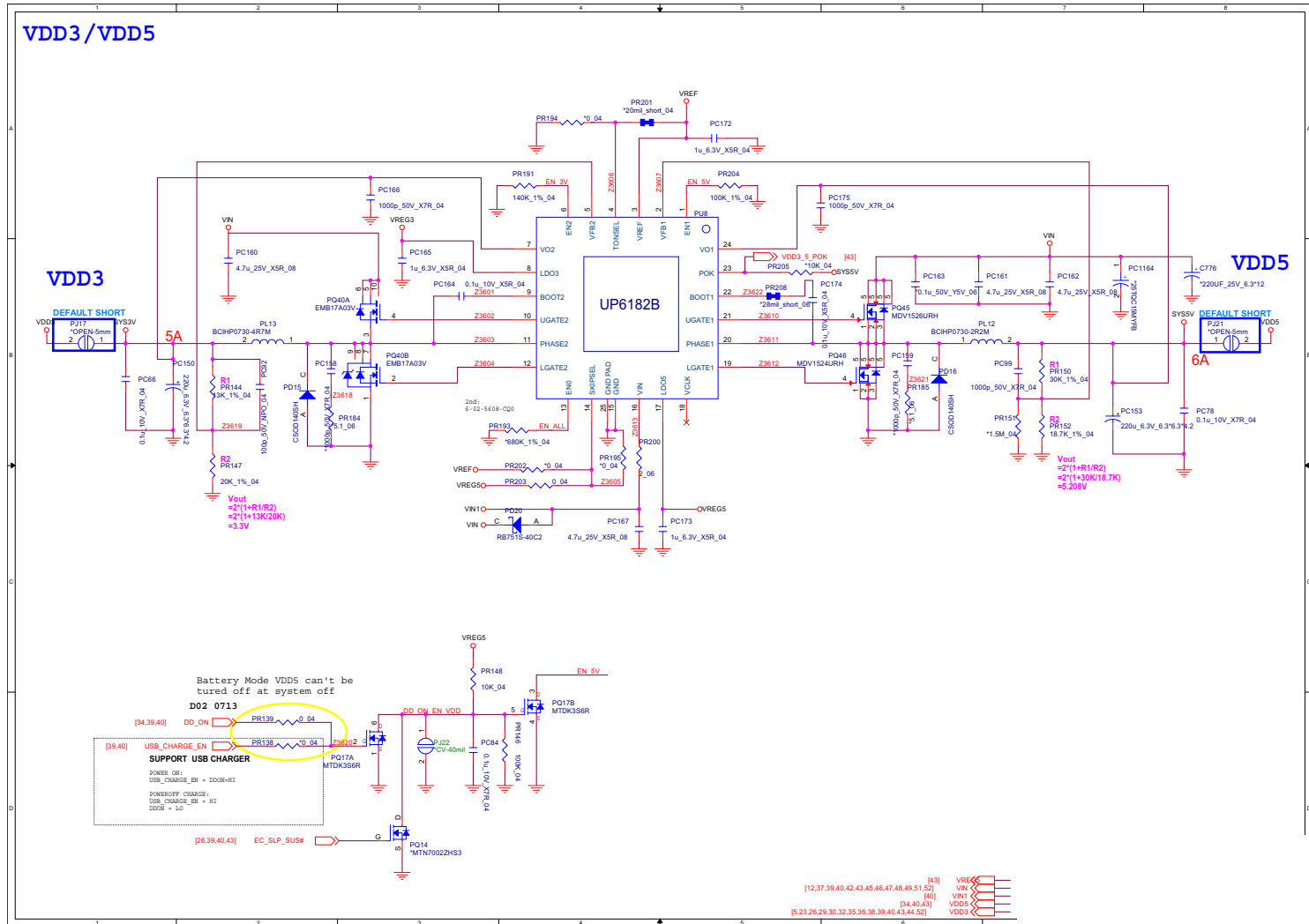

# DRAM Power

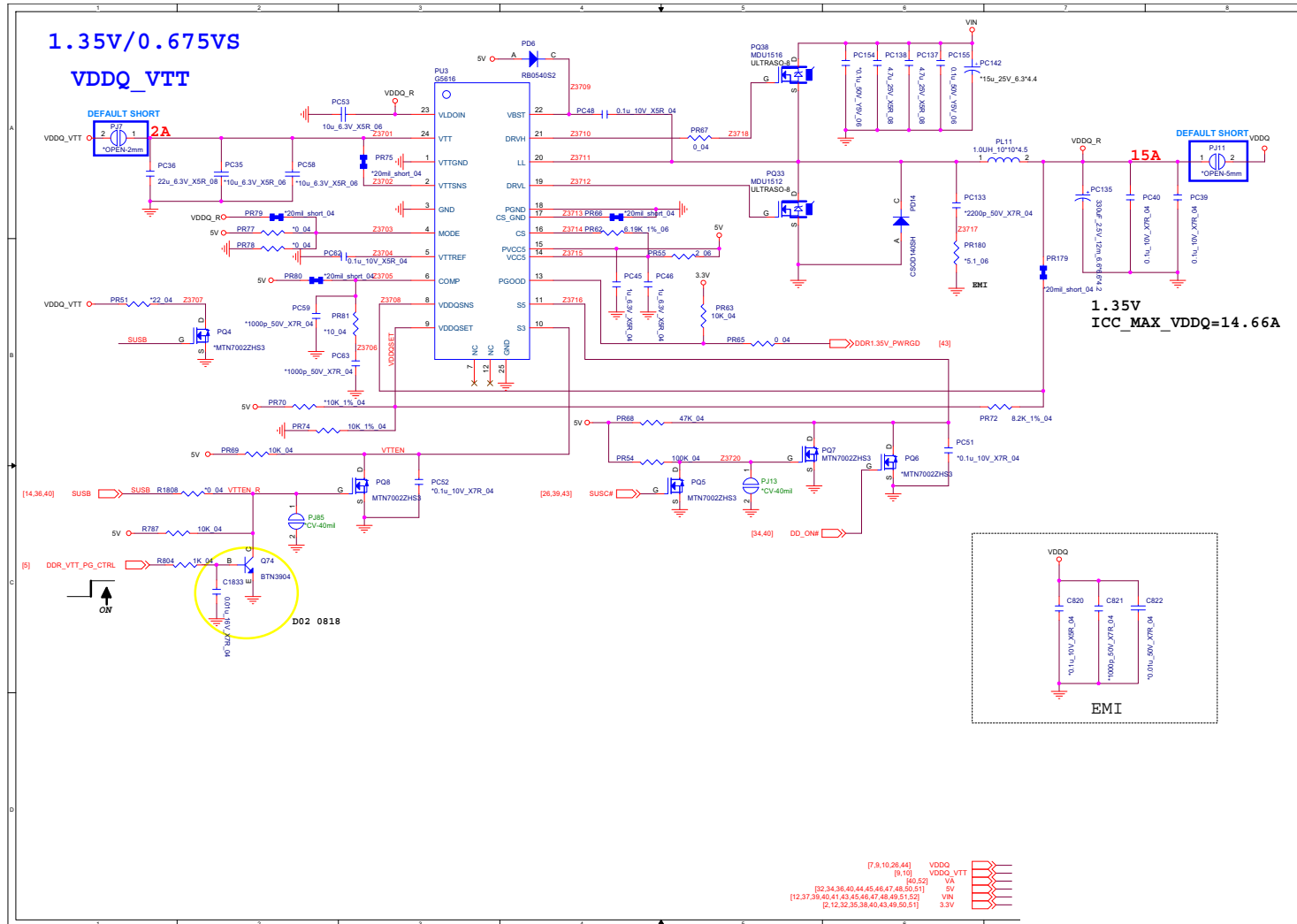

Sheet 42 of 62  
DRAM Power

B.Schematic Diagrams

# Schematic Diagrams

## Power 1.0V, VCCIO

Sheet 43 of 62  
Power 1.0V, VCCIO

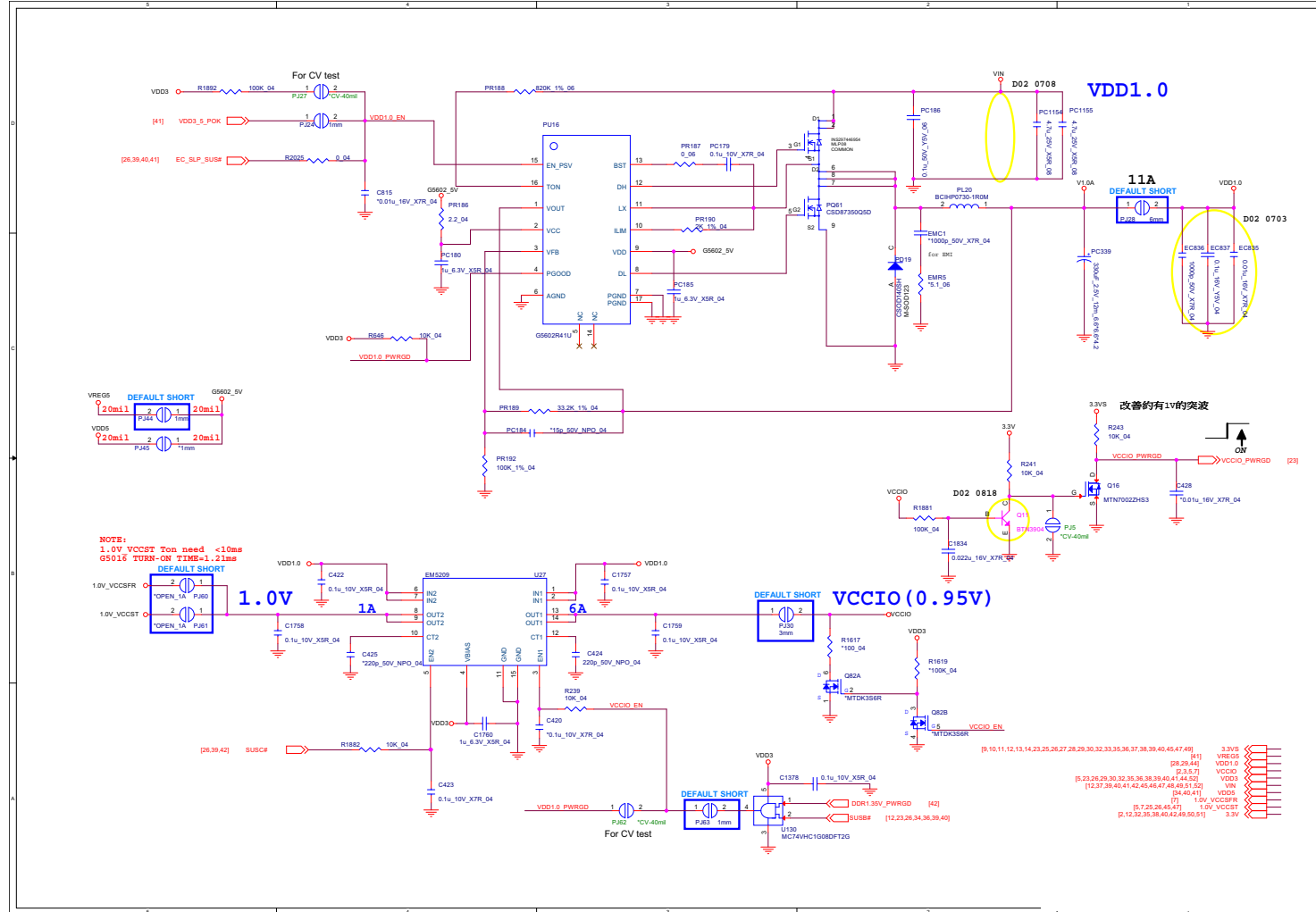

# 1.0DX\_VCCSTG/VCCSFR\_OC

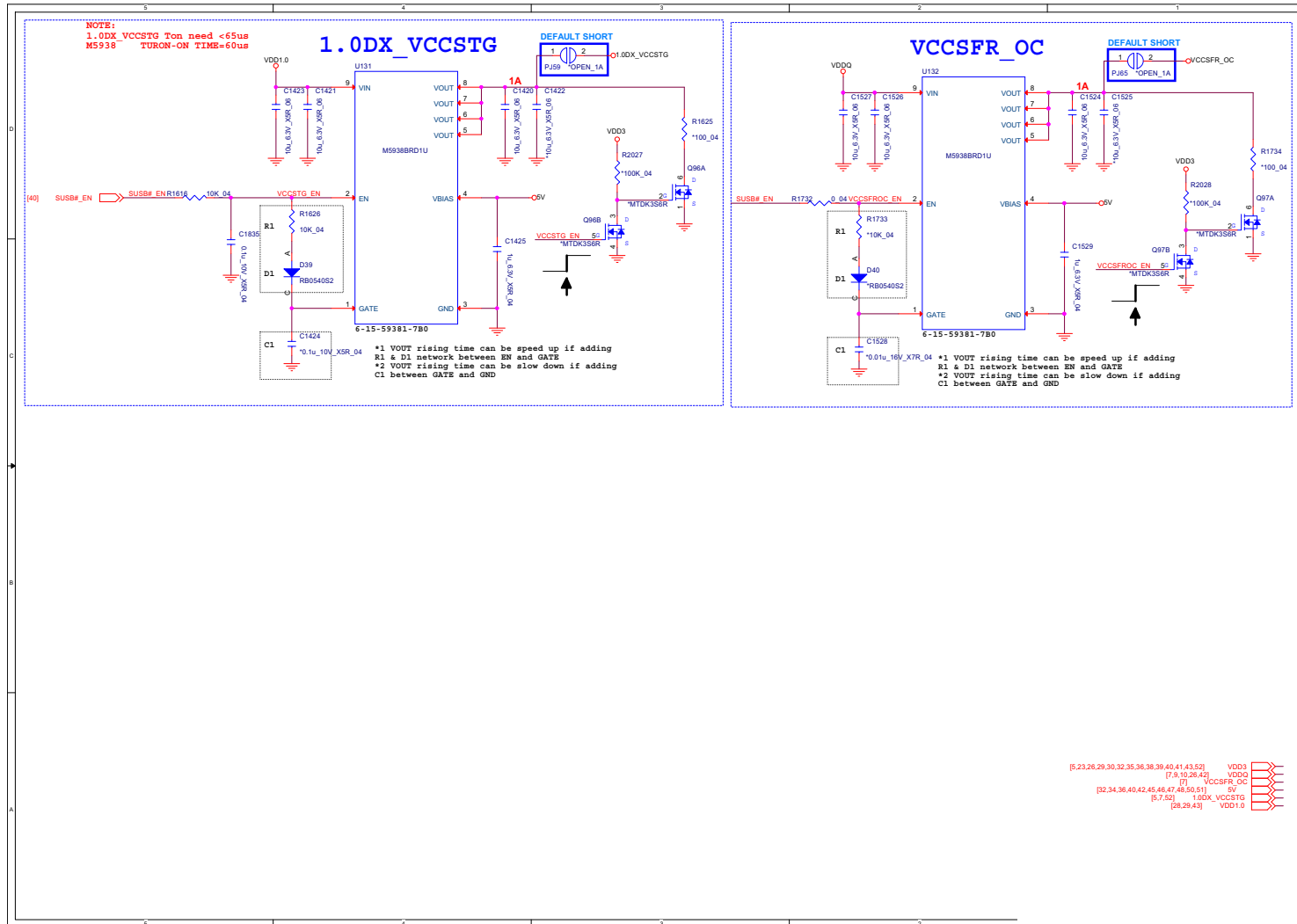

# VCore, VCCSA

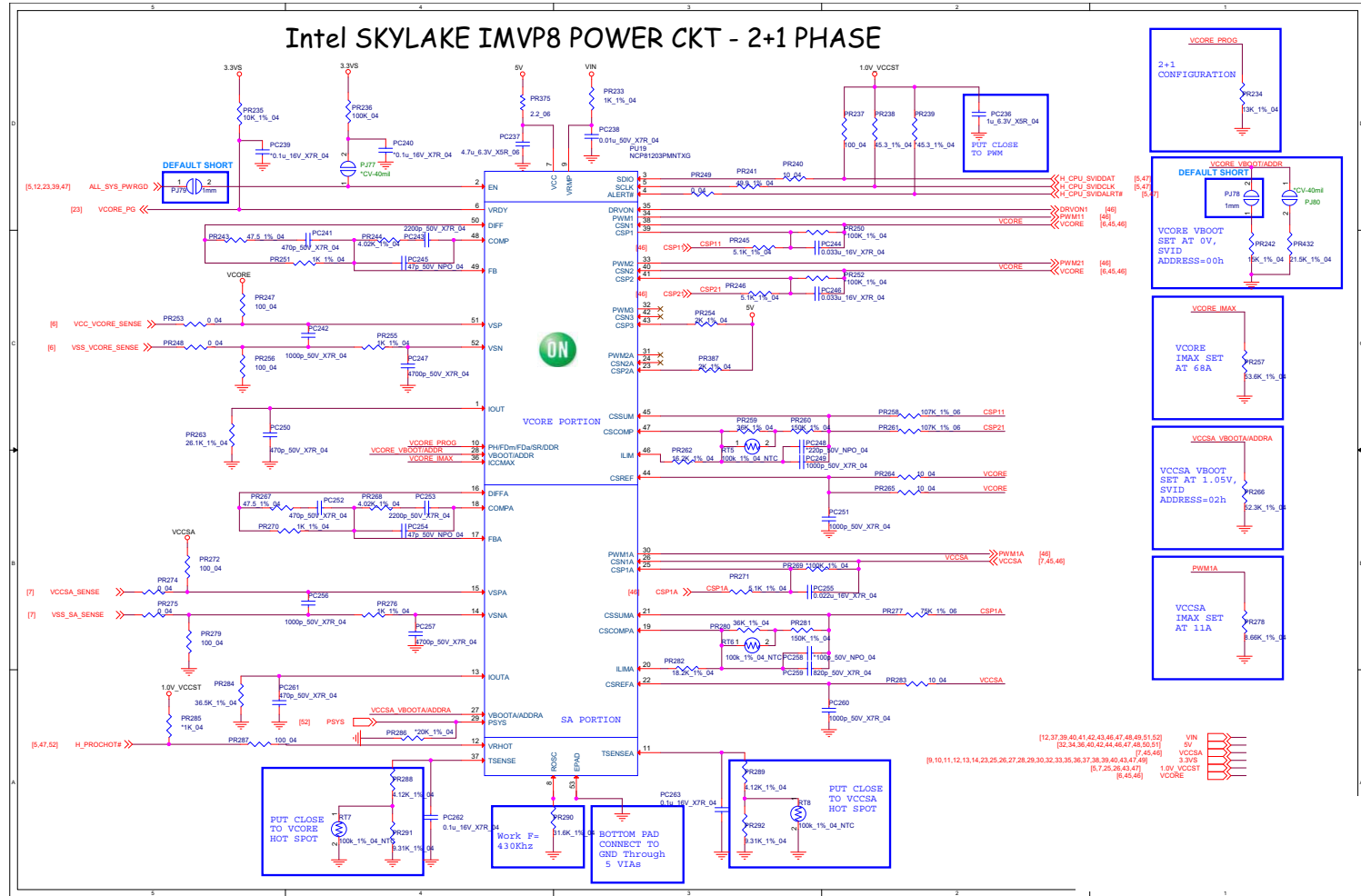

Sheet 45 of 62  
VCore, VCCSA

B.Schematic Diagrams



# VCore & VCCSA Output Stage

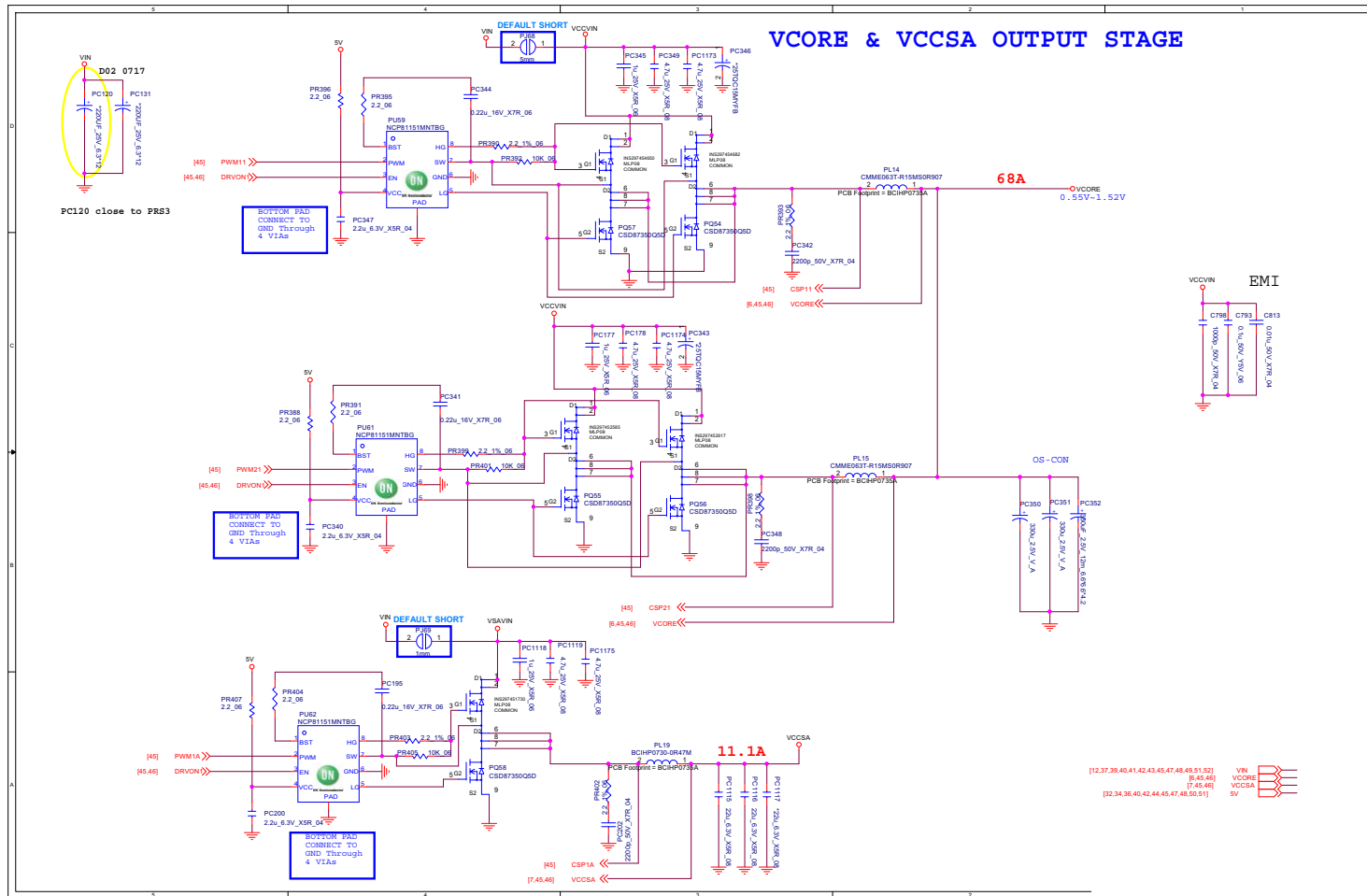

Sheet 46 of 62  
VCore & VCCSA  
Output Stage

B.Schematic Diagrams

# VCCGT

Sheet 47 of 62  
VCCGT

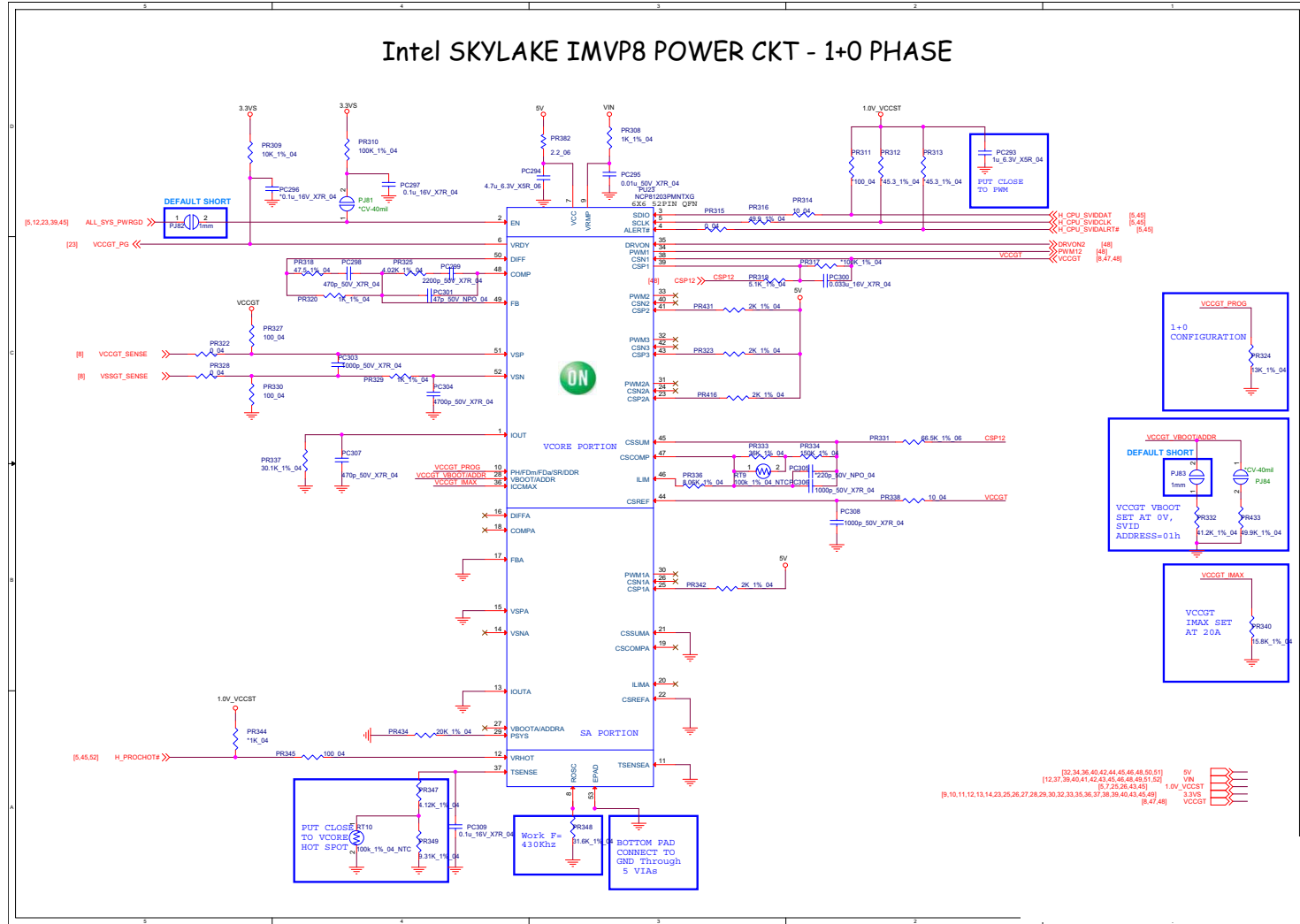

# VCCGT Output Stage

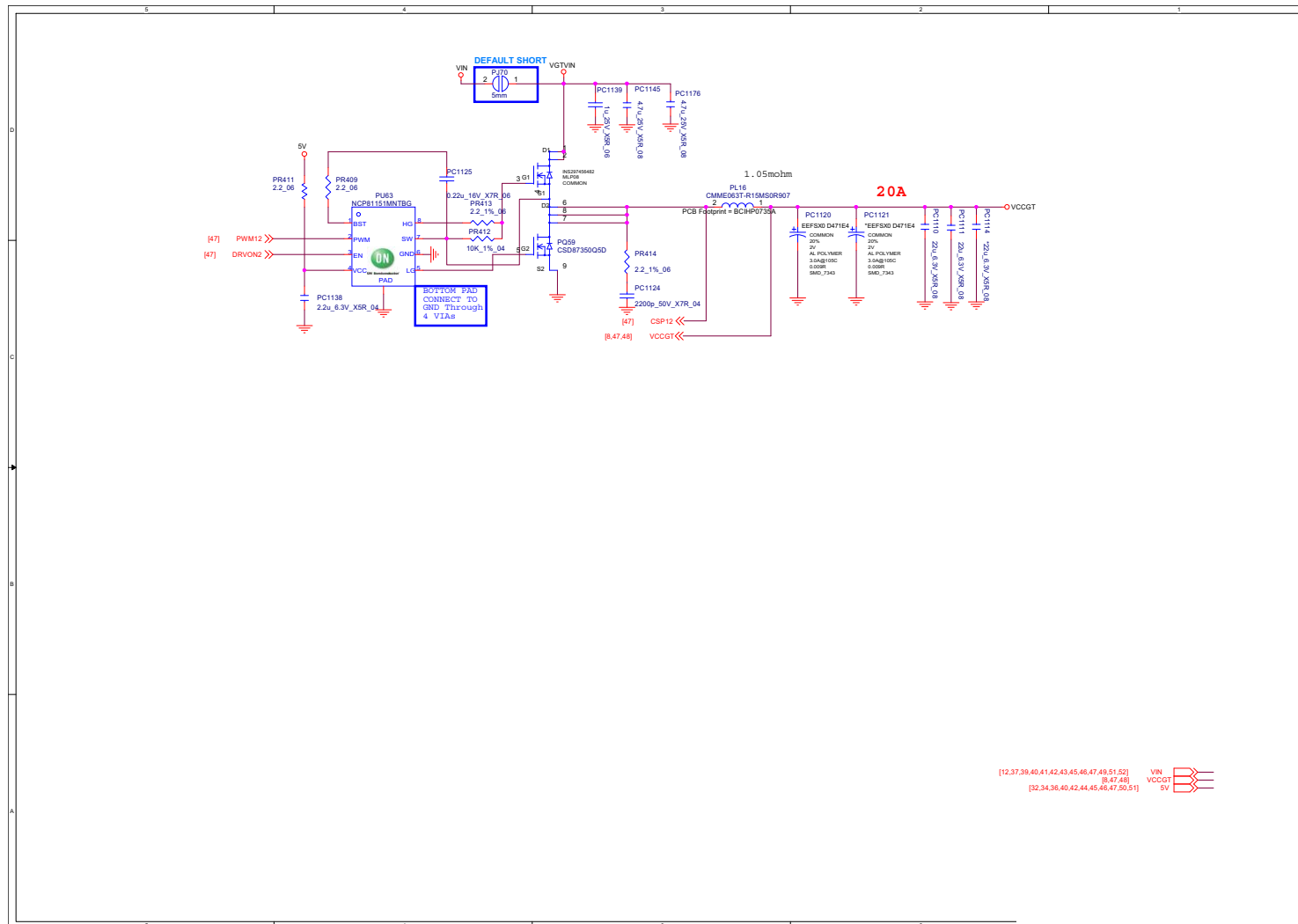

Sheet 48 of 62  
VCCGT Output Stage

B.Schematic Diagrams

## NVDD

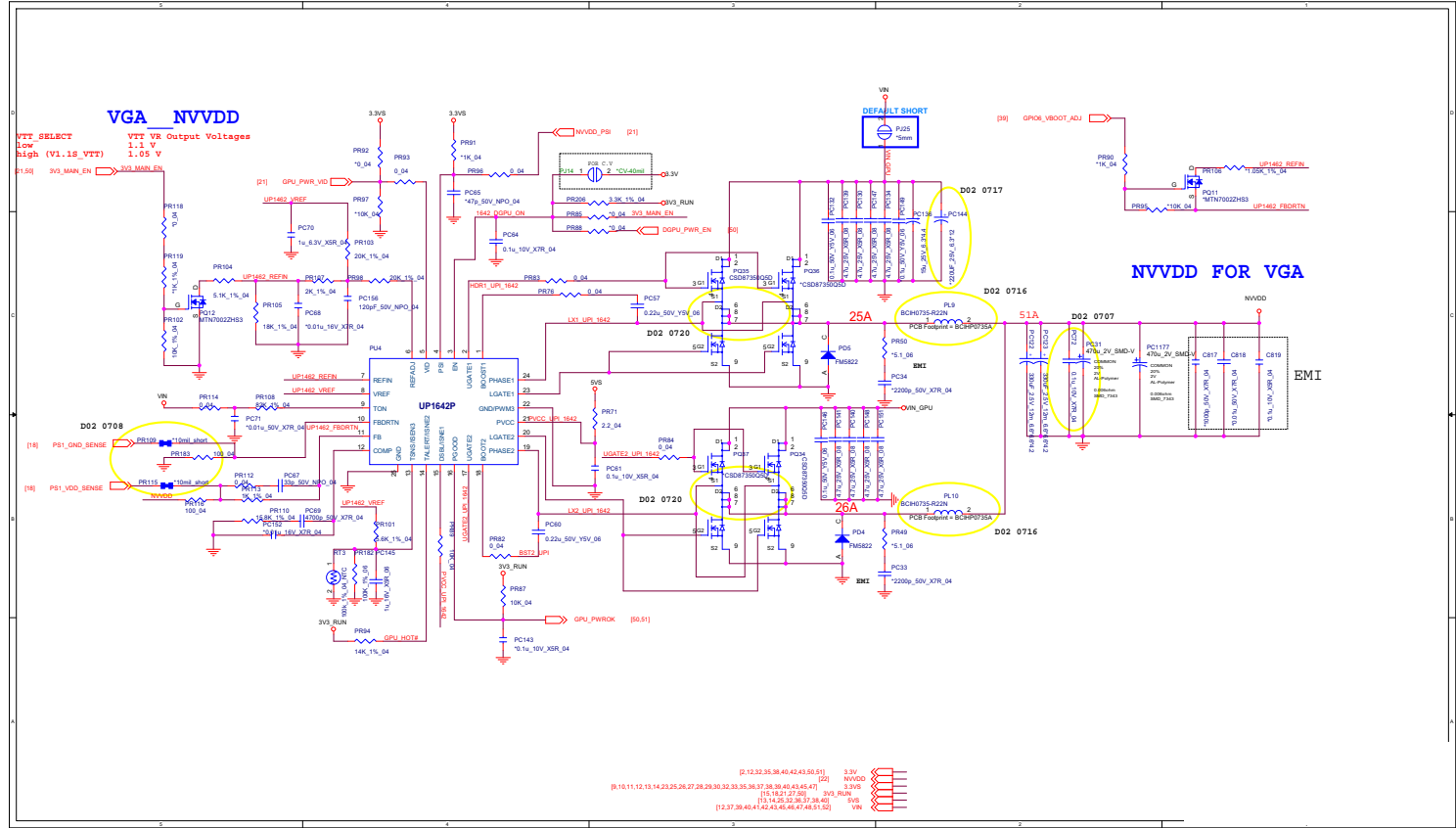

Sheet 49 of 62  
NVDD

B.Schematic Diagrams

# 3V3\_AON, 3V3\_RUN, PEX\_VDD

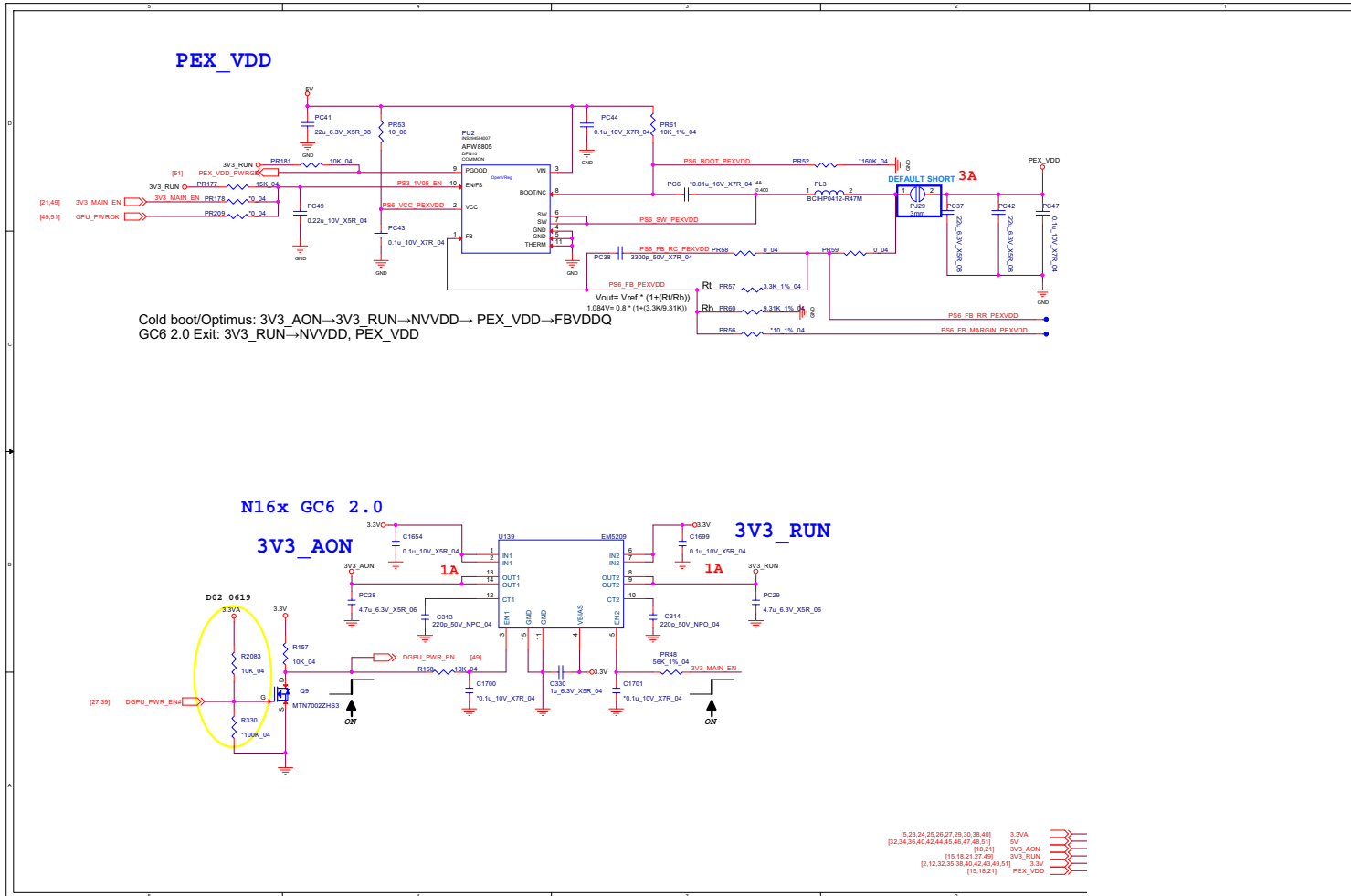

Sheet 50 of 62  
**3V3\_AON,  
 3V3\_RUN,  
 PEX\_VDD**

# Schematic Diagrams

## FBVDDQ

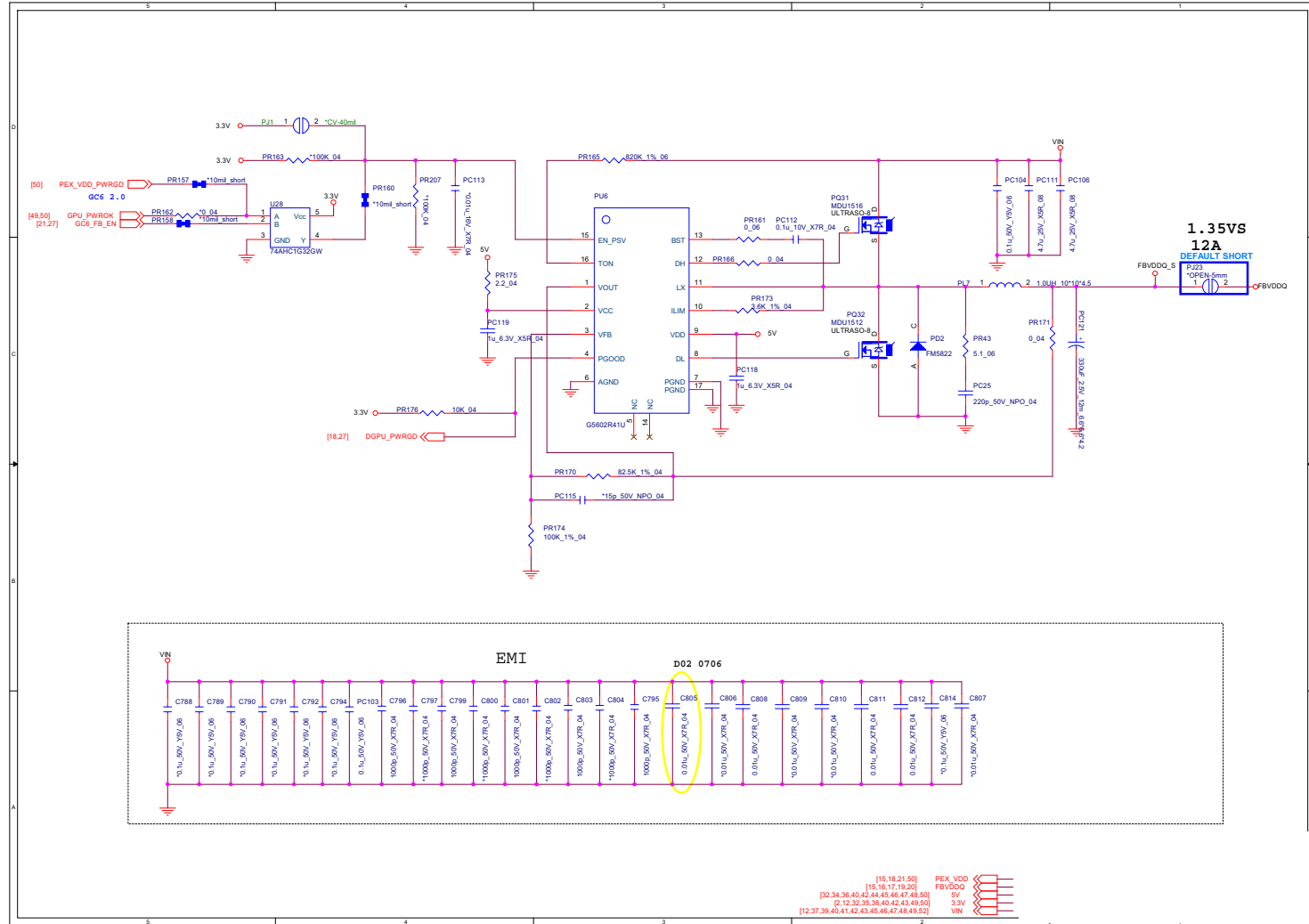

Sheet 51 of 62  
FBVDDQ

B.Schematic Diagrams

# AC-In, Charger

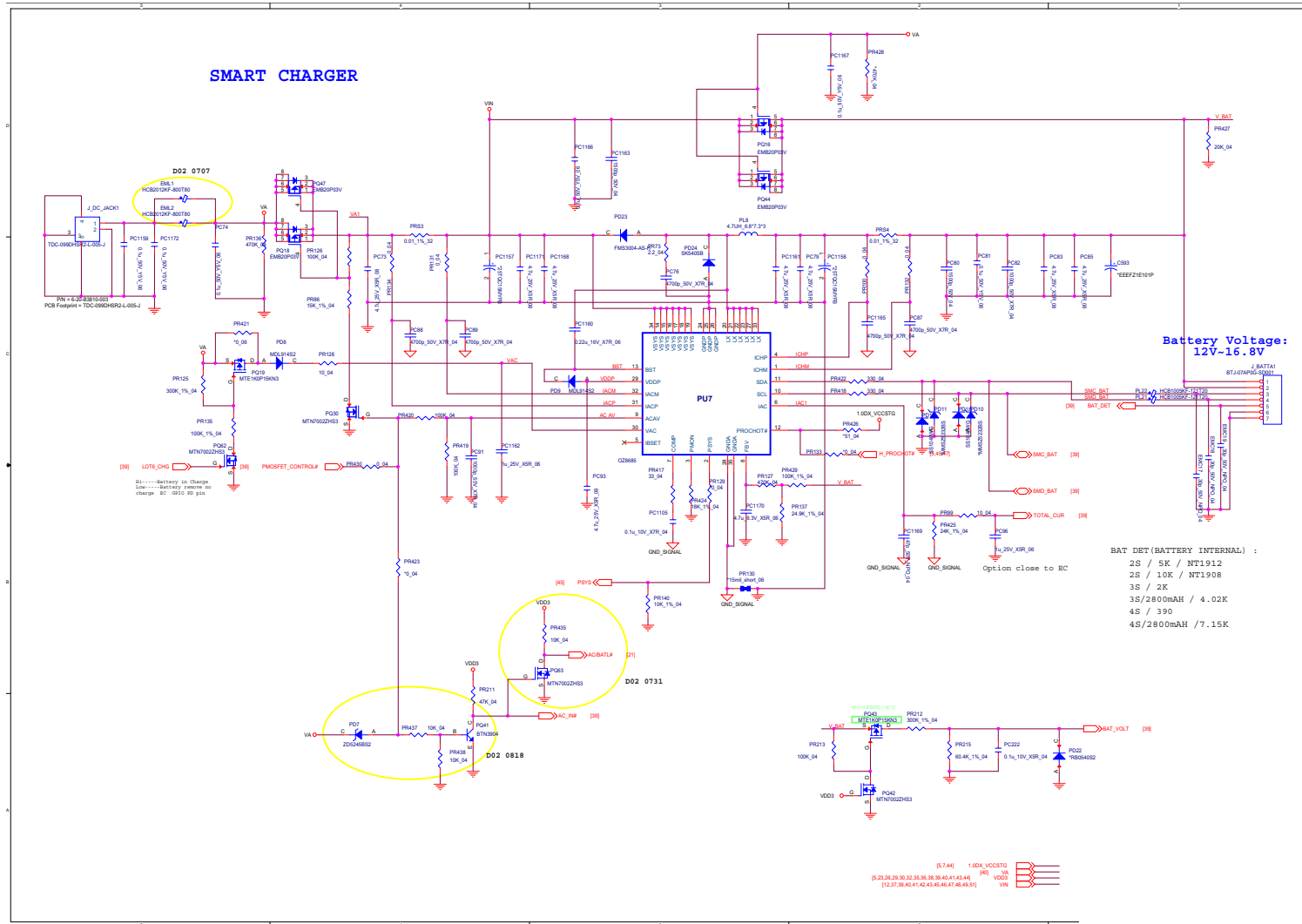

Sheet 52 of 62  
AC-In, Charger

B.Schematic Diagrams

# N155, N157 KB LED, PWR Board

Sheet 53 of 62  
N155, N157 KB  
LED, PWR Board

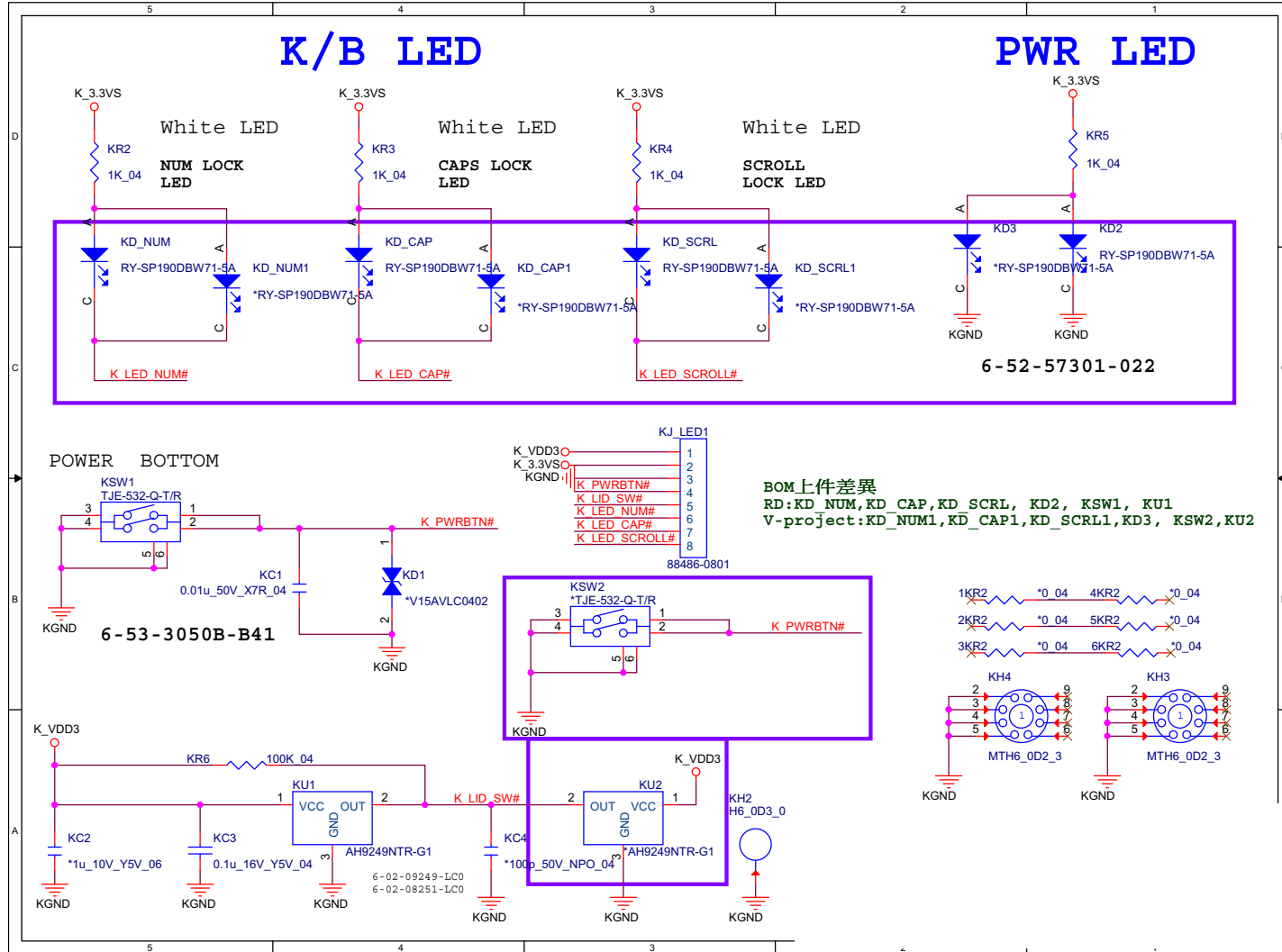



# Audio Board

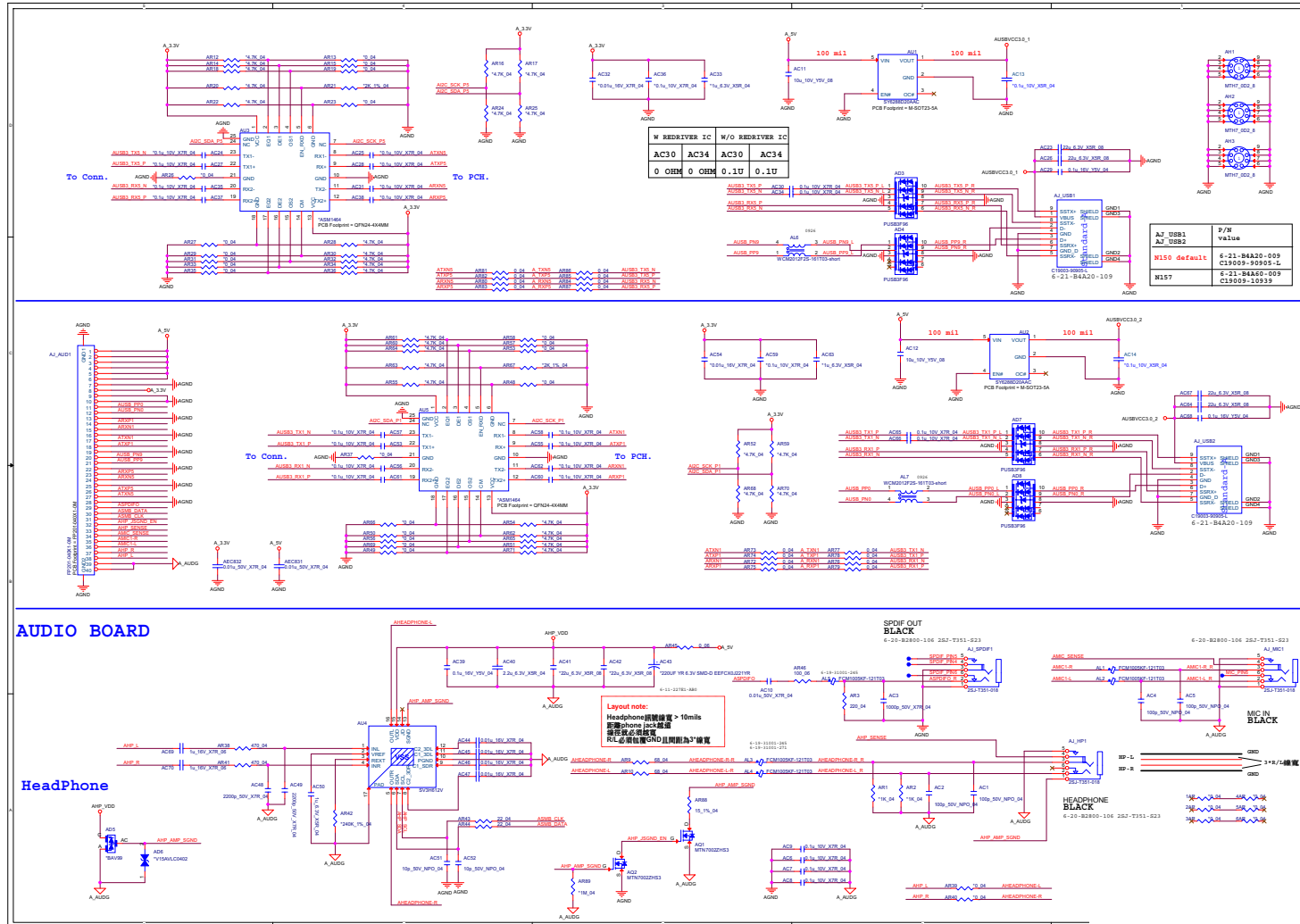

Sheet 54 of 62  
Audio Board

B.Schematic Diagrams

Schematic Diagrams

Front LED Board

B.Schematic Diagrams

Sheet 55 of 62  
Front LED Board

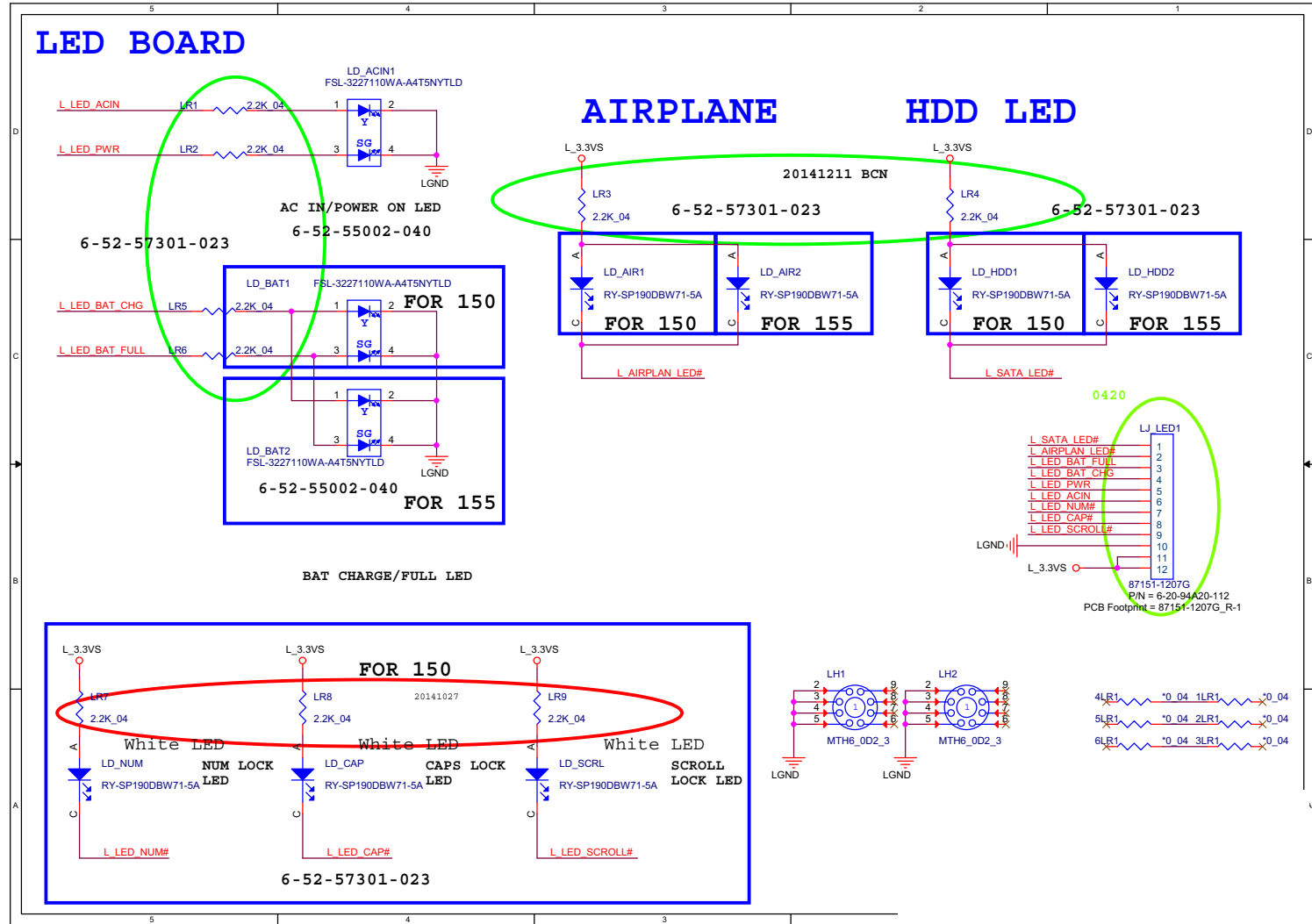

# Click / Finger Con Board

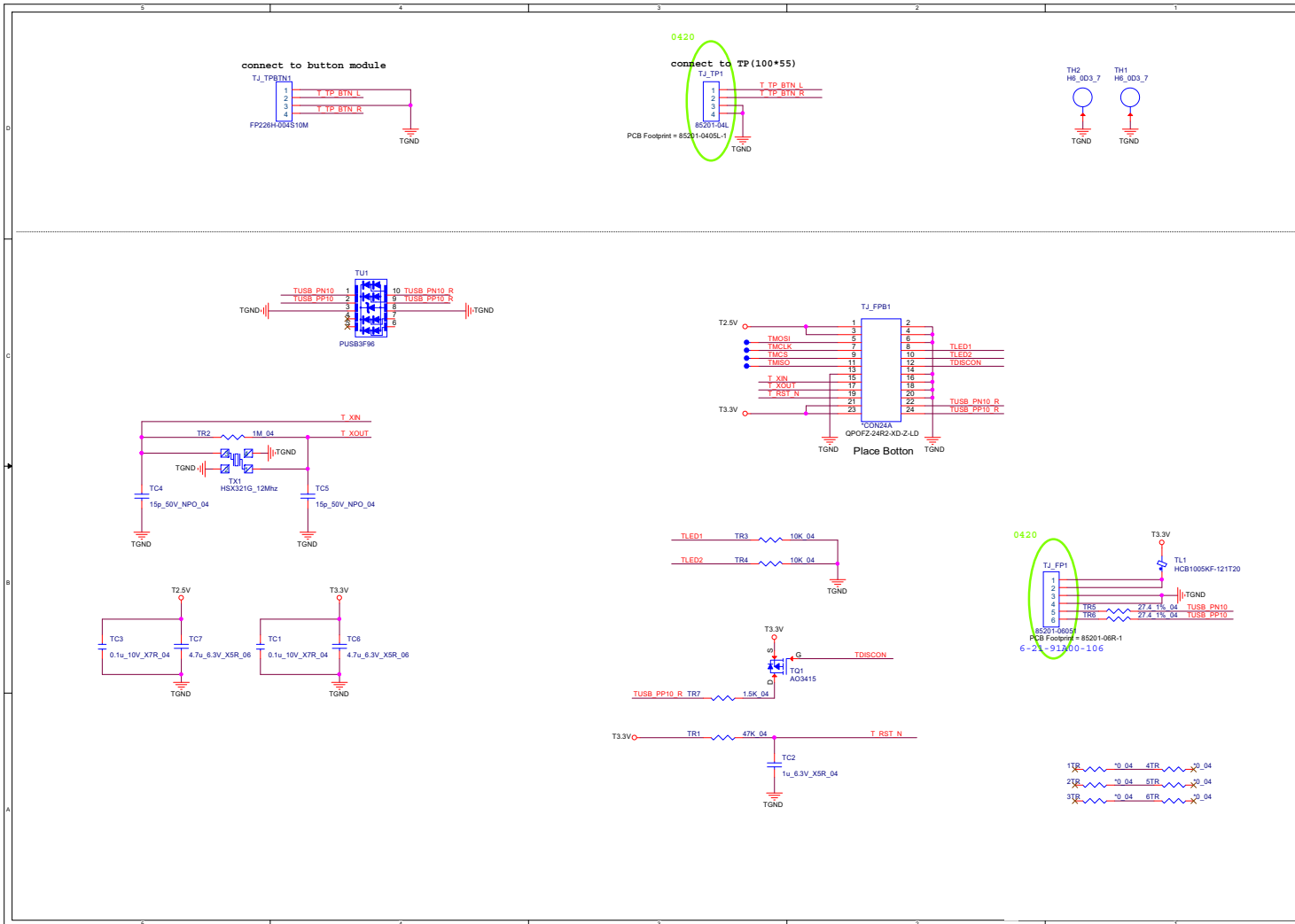

Sheet 56 of 62  
Click / Finger Con Board

B.Schematic Diagrams

# Fingerprint Board

Sheet 57 of 62  
Fingerprint Board

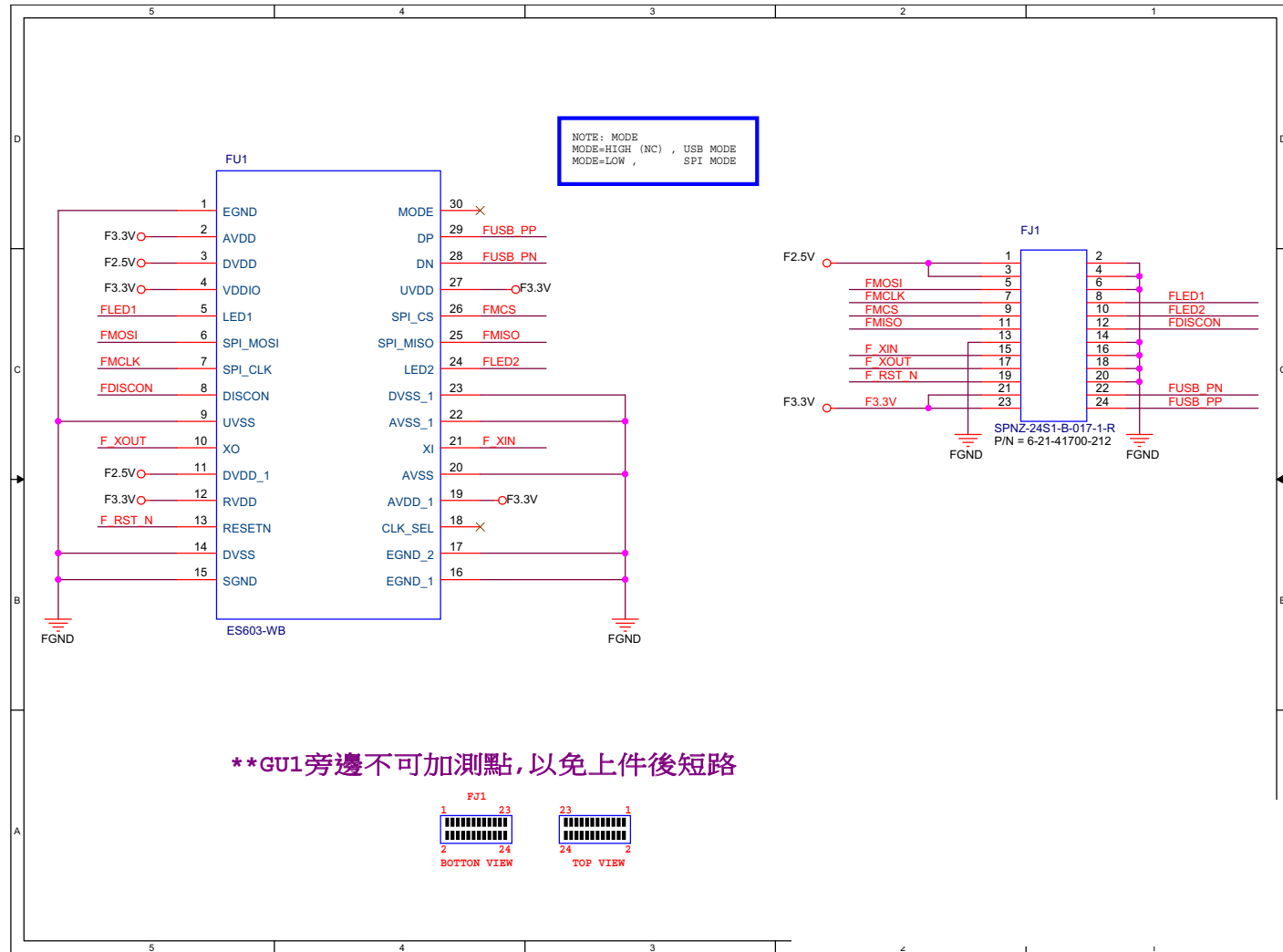

# N150 LID, PWR SW Board

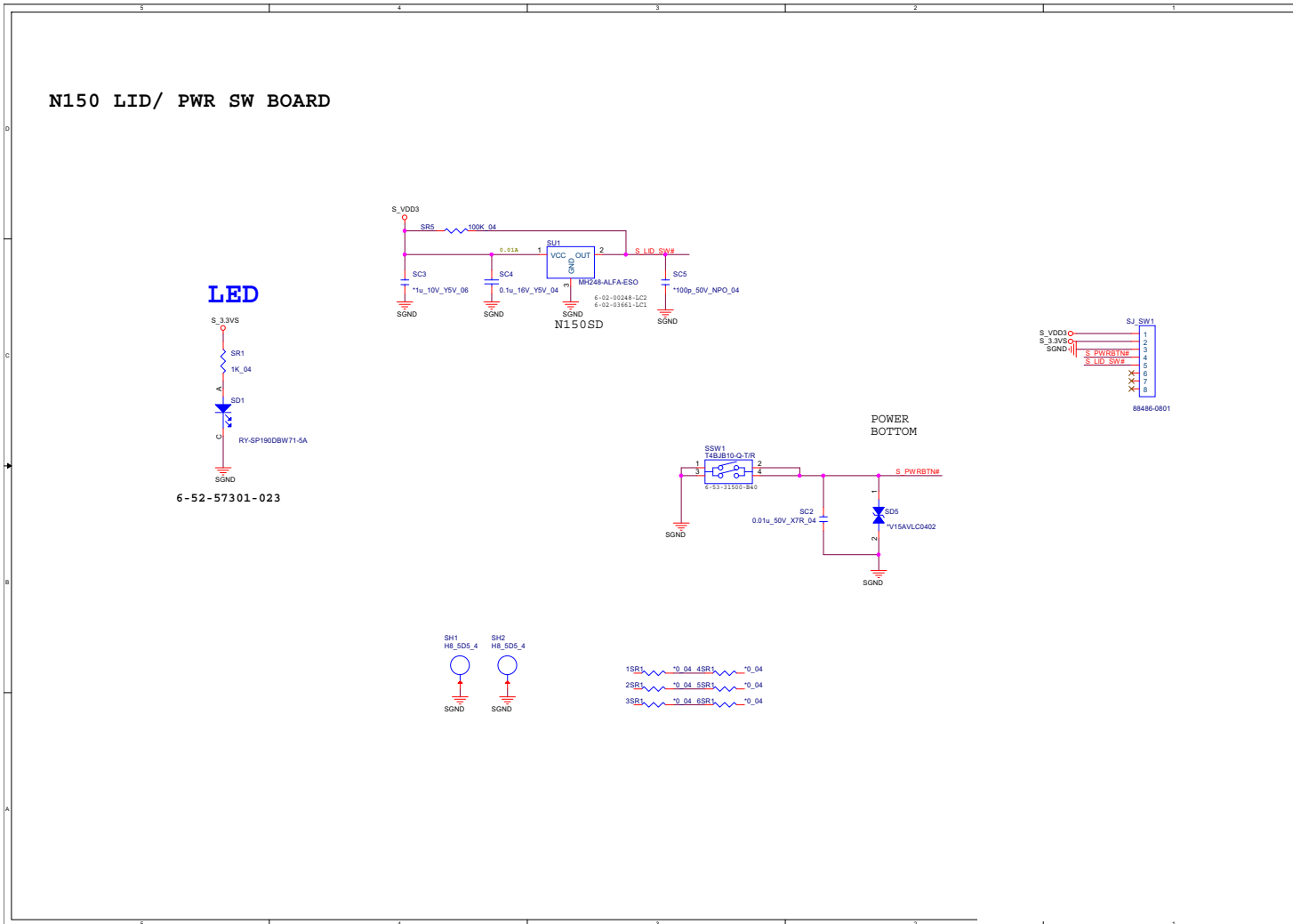

Sheet 58 of 62  
N150 LID, PWR SW  
Board

# N170 LID, PWR SW Board

Sheet 59 of 62  
N170 LID, PWR SW  
Board

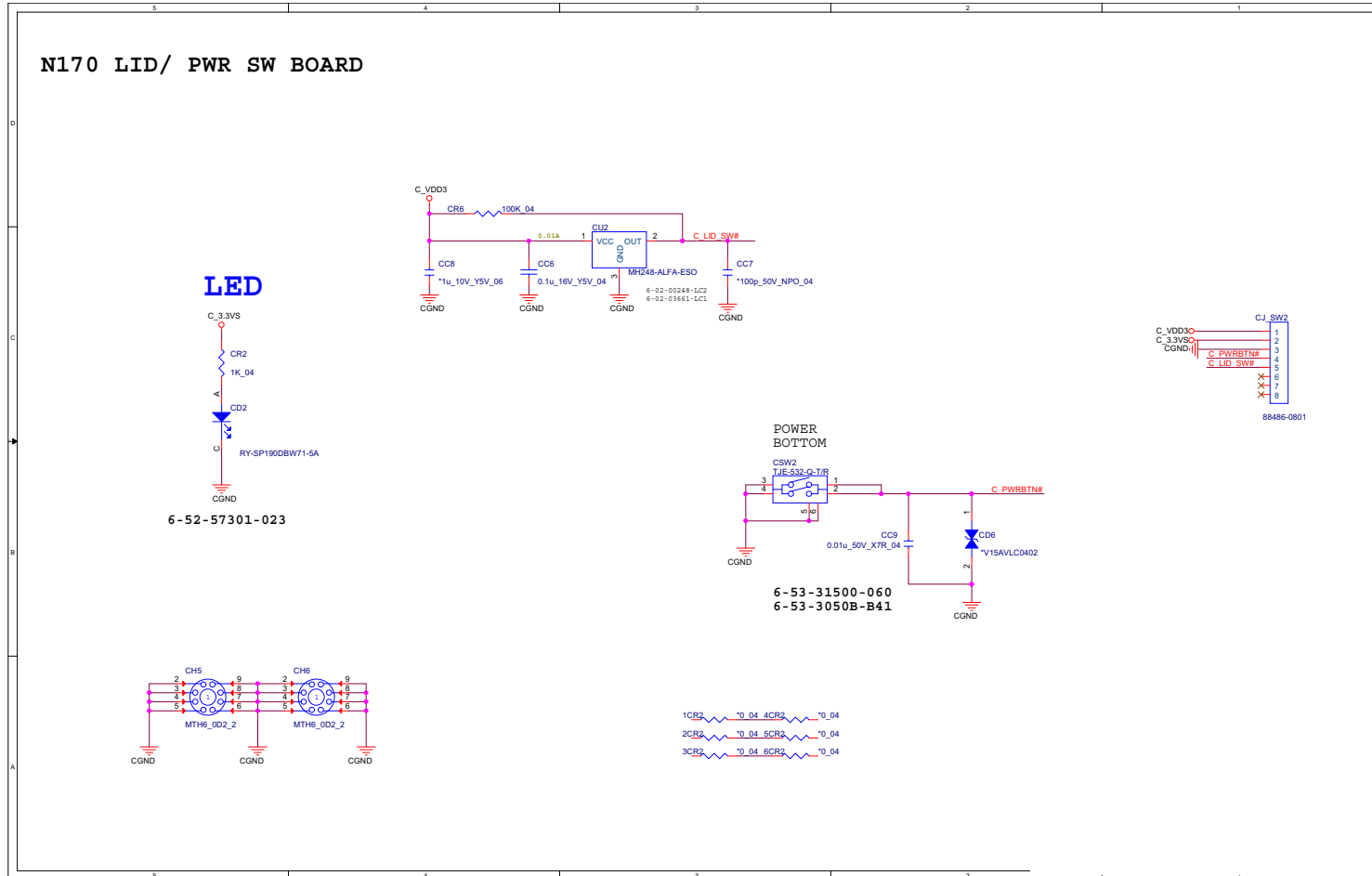

N170 ODD Ext. Board

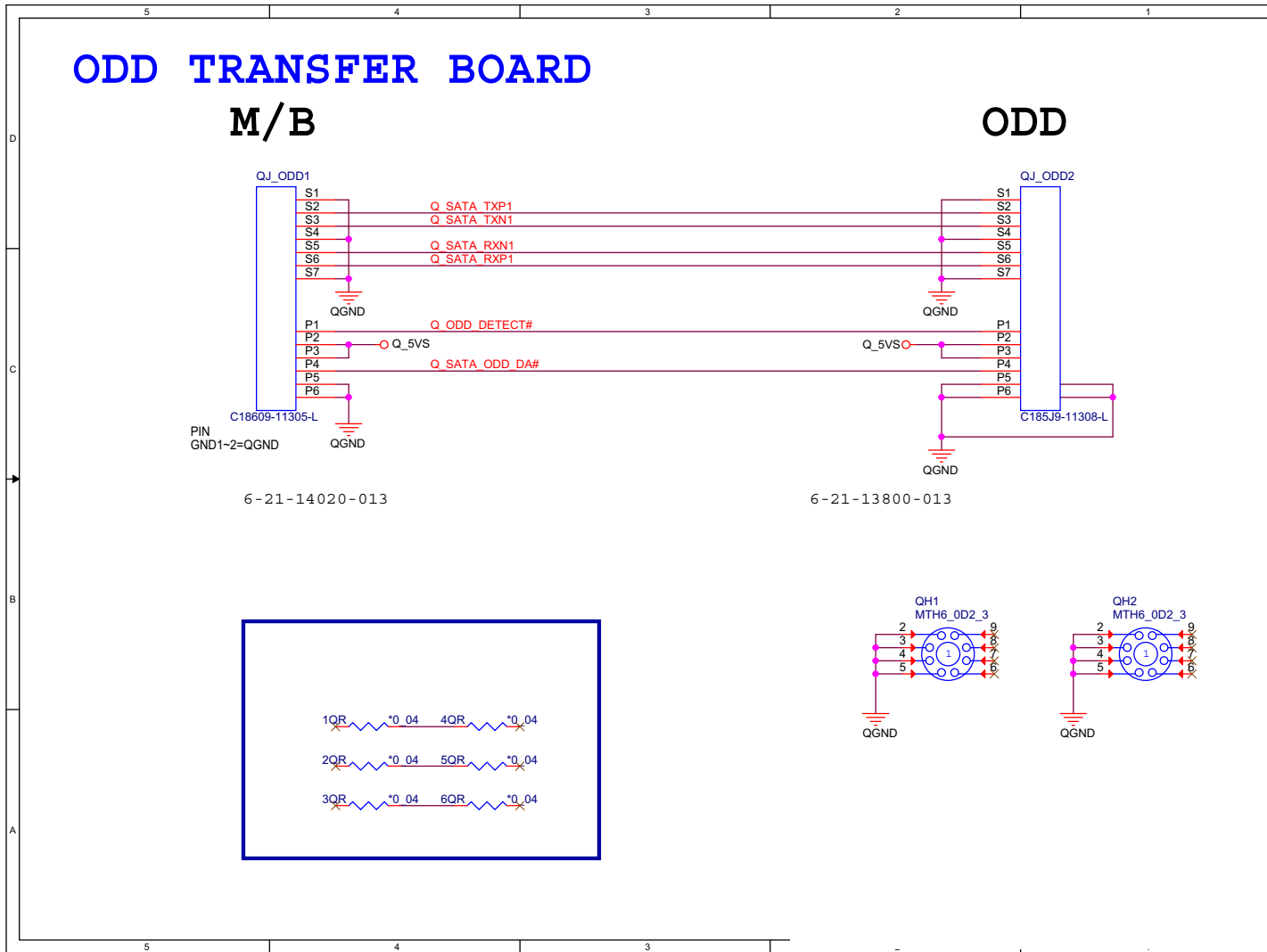

Sheet 60 of 62  
N170 ODD Ext.  
Board

# Power Sequence

Sheet 61 of 62  
Power Sequence

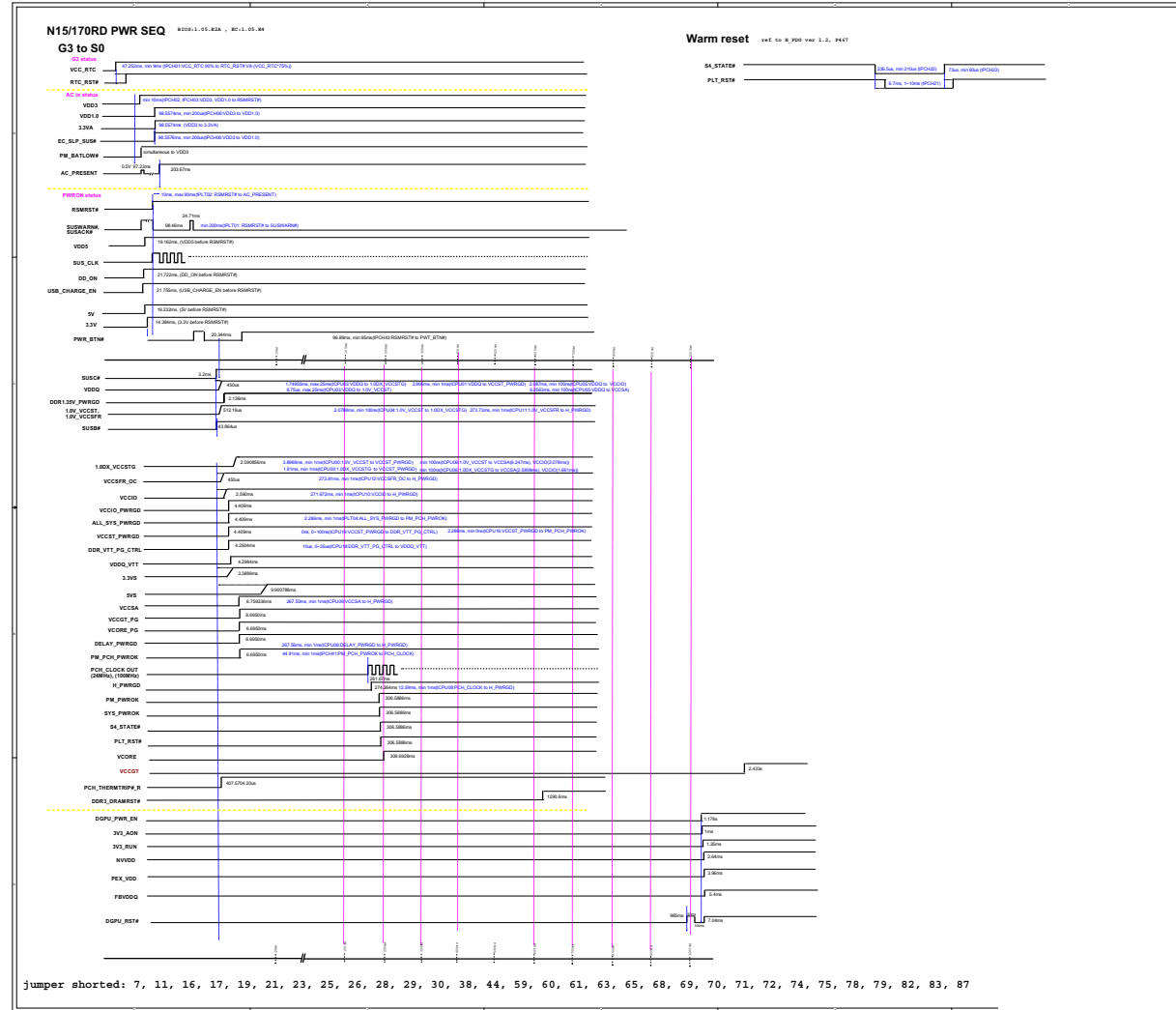



# Option BOM

LVDS		eDP		4G		N15		N17		N150 default		N157	
R240	0 04	R1950	0 04	R312	0 04	J KE2		J KB1		J USB2	6-21-B4A20-009	C19009-90905-L	6-21-B4A60-009
R237	0 04	R1951	0 04	R1966	0 04	J_LEDKB2	J_LEDKB1	J_LEDKB1		AJ_USB1	C19009-90905-L	C19009-10939	
R224	0 04	R1952	0 04	R326	10 06	R329	0 04	R315	10K_04	R316	10K_04	MODEL ID	
R220	0 04	R1953	0 04	R335	100K 04	R335	100K 04	W/ USB CHARGER		W/O USB CHARGER			
R1876	0 04	R1954	0 04	R617	10K 04	R338	230K 04	R457	0 04	R1810	0 04		
R225	0 04	R1957	0 04	R617	10K 04	C539	470p-50V X7R 04	R462	10K 04	R219	0 04		
R226	0 04	R1947	0 04	R338	230K 04	C1796	0.01u 16V X7R 04	R454	100K 04	R455	0 04		
R227	0 04	R180	0 04	C539	470p-50V X7R 04	C1709	0.1u 10V X7R 04	C700	0.1u 10V X5R 04	R620	100K 04		
R207	0 04	R261	0 04	C1796	0.01u 16V X7R 04	C1710	0.1u 10V X7R 04	U35	SL65553VTR	PR159	0 04		
R205	0 04	R246	1K 04	C1709	0.1u 10V X7R 04	C532	0.1u 10V X5R 04	PR138	0 04				
R175	0 04	R203	100K 04	C1710	0.1u 10V X7R 04	C537	0.1u 10V X5R 04						
R1948	0 04	R210	100K 04	C532	0.1u 10V X5R 04	C537	0.1u 10V X5R 04						
R1962	0 04	C393	0.1u 10V X7R 04	C537	0.1u 10V X5R 04	C535	0.1u 10V X5R 04						
R1963	0 04	C396	0.1u 10V X7R 04	C535	0.1u 10V X5R 04	C782	0.1u 10V X5R 04						
R1949	1K 04	C455	0.1u 10V X7R 04	C782	0.1u 10V X5R 04	C748	0.1u 10V X5R 04						
R138	2.2K 04	C444	0.1u 10V X7R 04	C748	0.1u 10V X5R 04	C592	0.1u 10V X5R 04						
R141	2.2K 04	C456	0.1u 10V X7R 04	C592	0.1u 10V X5R 04	C594	1u 6.3V X5R 04						
R1958	4.7K 04	C417	0.1u 10V X7R 04	C594	1u 6.3V X5R 04	C779	10u 6.3V X5R 06						
R1964	4.7K 04	C388	0.1u 10V X7R 04	C779	10u 6.3V X5R 06	C736	220u 6.3V 6.3*6.3*4.2						
R1944	10K 04	C391	0.1u 10V X7R 04	C736	220u 6.3V 6.3*6.3*4.2	C778	220u 6.3V 6.3*6.3*4.2						
R1945	10K 04	C1762	0.1u 10V X7R 04	C778	220u 6.3V 6.3*6.3*4.2	Q22	MPS3572G6						
R1955	4.99K 1% 04	C1763	0.1u 10V X7R 04	Q22	MPS3572G6	J 3G1	51736-06702-002						
R1956	4.99K 1% 04	C474	0.1u 16V V5V 04	J SIM1	91712-0090P-001	HZ4	H7 5B5_0D3_7						
C1785	0.1u 10V X7R 04												
C1786	0.1u 10V X7R 04												
C1787	0.1u 10V X5R 04												
C1788	0.1u 10V X7R 04												
C1791	0.1u 10V X7R 04												
C1792	0.1u 10V X7R 04												
C1793	0.1u 10V X7R 04												
C1795	0.1u 10V X7R 04												
C1787	0.1u 10V X5R 04												
C1783	0.1u 10V X7R 04												
C1780	0.1u 10V X7R 04												
C1775	0.47u 10V V5V 04												
C1776	0.47u 10V V5V 04												
C1794	0.01u 16V X7R 04												
C1788	0.01u 16V X7R 04												
C1776	1u 6.3V X5R 04												
C1784	1u 6.3V X5R 04												
C1781	1u 6.3V X5R 04												
C286	4.7u 6.3V X5R 06												
C1779	4.7u 6.3V X5R 06												
C1789	4.7u 6.3V X5R 06												
C1782	2.2u 6.3V X5R 04												
C1777	22u 6.3V X5R 06												
L71	HCB1005KF-121T20												
L72	HCB1005KF-121T20												
L74	HCB1005KF-121T20												
L73	BCNR3010C-2R2M												
U24	P88625												
						W/ TPM		W/O TPM					
						U25	SLB9665TT	U25	*SLB9665TT				
						R292	10K	R297	100K				
										N16P-GX		N16E-GR	
										R2082	0 06	R2081	0 06
										R1988	*0_04	R1988	*0_04

Sheet 62 of 62  
Option BOM

B.Schematic Diagrams

**Schematic Diagrams**

# Appendix C: Updating the FLASH ROM BIOS

## To update the FLASH ROM BIOS, you must:

- Download the BIOS update from the web site.
- Unzip the files onto a bootable CD/DVD/USB Flash Drive.
- Reboot your computer from an external CD/DVD/USB Flash Drive.
- Use the flash tools to update the flash BIOS using the commands indicated below.
- Restart the computer booting from the HDD and press **F2** at startup enter the BIOS.
- Load setup defaults from the BIOS and save the default settings and exit the BIOS to restart the computer.
- After rebooting the computer you may restart the computer again and make any required changes to the default BIOS settings.

## Download the BIOS

1. Go to [www.clevo.com.tw](http://www.clevo.com.tw) and point to **E-Services** and click **E-Channel**.
2. Use your user ID and password to access the appropriate download area (BIOS), and download the latest BIOS files (the BIOS file will be contained in a batch file that may be run directly once unzipped) for your computer model (see sidebar for important information on BIOS versions).

## Unzip the downloaded files to a bootable CD/DVD or USB Flash drive

1. Insert a bootable CD/DVD/USB flash drive into the CD/DVD drive/USB port of the computer containing the downloaded files.
2. Use a tool such as Winzip or Winrar to unzip all the BIOS files and refresh tools to your bootable CD/DVD/USB flash drive (you may need to create a bootable CD/DVD with the files using a 3rd party software).

## Set the computer to boot from the external drive

1. With the bootable CD/DVD/USB flash drive containing the BIOS files in your CD/DVD drive/USB port, restart the computer and press **F2** (in most cases) to enter the BIOS.
2. Use the arrow keys to highlight the **Boot** menu.
3. Use the “+” and “-” keys to move boot devices up and down the priority order.
4. Make sure that the CD/DVD drive/USB flash drive is set first in the boot priority of the BIOS.
5. Press **F4** to save any changes you have made and exit the BIOS to restart the computer.



### BIOS Version

Make sure you download the latest correct version of the BIOS appropriate for the computer model you are working on.

You should only download BIOS versions that are **V1.00.XX or higher** as appropriate for your computer model.

Note that BIOS versions are not backward compatible and therefore **you may not downgrade your BIOS to an older version** after upgrading to a later version (e.g if you upgrade a BIOS to ver 1.00.05, you **MAY NOT** then go back and flash the BIOS to ver 1.00.04).

## BIOS Update

---

### Use the flash tools to update the BIOS

1. Make sure you are not loading any memory management programs such as HIMEM by holding the **F8** key as you see the message “**EFI Shell**”. You will then be prompted to give “**Y**” or “**N**” responses to the programs being loaded by EFI Shell. Choose “**N**” for any memory management programs.
2. You should now see **DISK fsX:\>** (X is the designated drive number for the CD/DVD drive/USB flash drive).
3. **Type the following command:**

**fsX:\> Flash.nsh**

4. The utility will then proceed to flash the BIOS.
5. You should then be prompted to press any key to restart the system or turn the power off, and then on again but make sure you remove the CD/DVD/USB flash drive from the CD/DVD drive/USB port before the computer restarts.

### Restart the computer (booting from the HDD)

1. With the CD/DVD/USB flash drive removed from the CD/DVD drive/USB port the computer should restart from the HDD.
2. Press **F2** as the computer restarts to enter the BIOS.
3. Use the arrow keys to highlight the **Exit** menu.
4. Select **Load Setup Defaults** (or press **F3**) and select “**Yes**” to confirm the selection.
5. Press **F4** to save any changes you have made and exit the BIOS to restart the computer.

### Your computer is now running normally with the updated BIOS

You may now enter the BIOS and make any changes you require to the default settings.