

SERVICE MANUAL

W25CSW

notebook



Notebook Computer

W25CSW

Service Manual

Notice

The company reserves the right to revise this publication or to change its contents without notice. Information contained herein is for reference only and does not constitute a commitment on the part of the manufacturer or any subsequent vendor. They assume no responsibility or liability for any errors or inaccuracies that may appear in this publication nor are they in anyway responsible for any loss or damage resulting from the use (or misuse) of this publication.

This publication and any accompanying software may not, in whole or in part, be reproduced, translated, transmitted or reduced to any machine readable form without prior consent from the vendor, manufacturer or creators of this publication, except for copies kept by the user for backup purposes.

Brand and product names mentioned in this publication may or may not be copyrights and/or registered trademarks of their respective companies. They are mentioned for identification purposes only and are not intended as an endorsement of that product or its manufacturer.

Version 1.0
March 2014

Trademarks

Intel, Pentium and Intel Core are trademarks of Intel Corporation.

Windows[®] is a registered trademark of Microsoft Corporation.

Other brand and product names are trademarks and /or registered trademarks of their respective companies.

About this Manual

This manual is intended for service personnel who have completed sufficient training to undertake the maintenance and inspection of personal computers.

It is organized to allow you to look up basic information for servicing and/or upgrading components of the **W25CSW** series notebook PC.

The following information is included:

Chapter 1, Introduction, provides general information about the location of system elements and their specifications.

Chapter 2, Disassembly, provides step-by-step instructions for disassembling parts and subsystems and how to upgrade elements of the system.

Appendix A, Part Lists

Appendix B, Schematic Diagrams

Appendix C, Updating the FLASH ROM BIOS

IMPORTANT SAFETY INSTRUCTIONS

Follow basic safety precautions, including those listed below, to reduce the risk of fire, electric shock and injury to persons when using any electrical equipment:

1. Do not use this product near water, for example near a bath tub, wash bowl, kitchen sink or laundry tub, in a wet basement or near a swimming pool.
2. Avoid using a telephone (other than a cordless type) during an electrical storm. There may be a remote risk of electrical shock from lightning.
3. Do not use the telephone to report a gas leak in the vicinity of the leak.
4. Use only the power cord and batteries indicated in this manual. Do not dispose of batteries in a fire. They may explode. Check with local codes for possible special disposal instructions.
5. This product is intended to be supplied by a Listed Power Unit with an AC Input of 100 - 240V, 50 - 60Hz, DC Output of 19V, 3.42A (65W) minimum AC/DC Adapter.

FCC Statement

This device complies with Part 15 of the FCC Rules. Operation is subject to the following two conditions:

This device may not cause harmful interference.

This device must accept any interference received, including interference that may cause undesired operation.

Instructions for Care and Operation

The notebook computer is quite rugged, but it can be damaged. To prevent this, follow these suggestions:

1. **Don't drop it, or expose it to shock.** If the computer falls, the case and the components could be damaged.



2. **Keep it dry, and don't overheat it.** Keep the computer and power supply away from any kind of heating element. This is an electrical appliance. If water or any other liquid gets into it, the computer could be badly damaged.

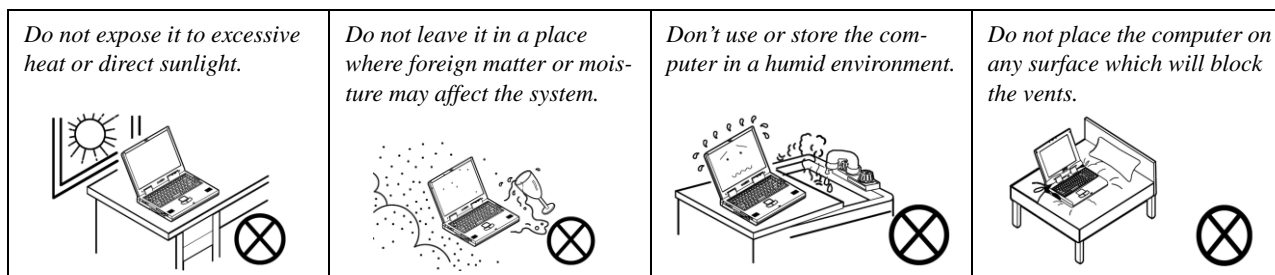

3. **Follow the proper working procedures for the computer.** Shut the computer down properly and don't forget to save your work. Remember to periodically save your data as data may be lost if the battery is depleted.

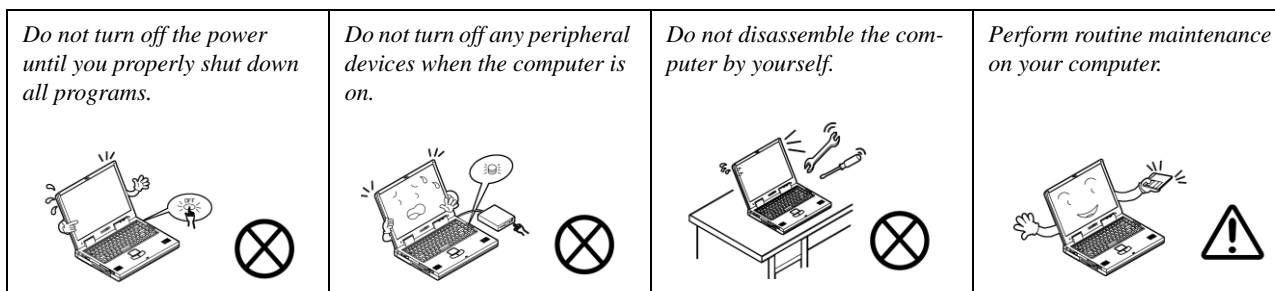

4. **Avoid interference.** Keep the computer away from high capacity transformers, electric motors, and other strong magnetic fields. These can hinder proper performance and damage your data.
5. **Take care when using peripheral devices.**

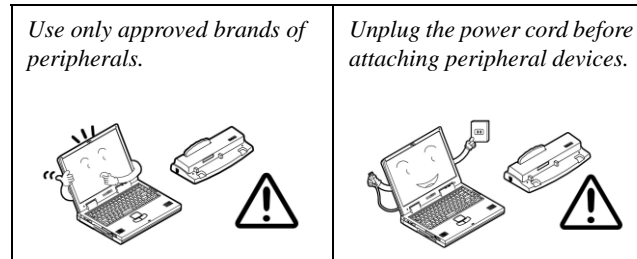

Power Safety

The computer has specific power requirements:

- Only use a power adapter approved for use with this computer.
- Your AC adapter may be designed for international travel but it still requires a steady, uninterrupted power supply. If you are unsure of your local power specifications, consult your service representative or local power company.
- The power adapter may have either a 2-prong or a 3-prong grounded plug. The third prong is an important safety feature; do not defeat its purpose. If you do not have access to a compatible outlet, have a qualified electrician install one.
- When you want to unplug the power cord, be sure to disconnect it by the plug head, not by its wire.
- Make sure the socket and any extension cord(s) you use can support the total current load of all the connected devices.
- Before cleaning the computer, make sure it is disconnected from any external power supplies.

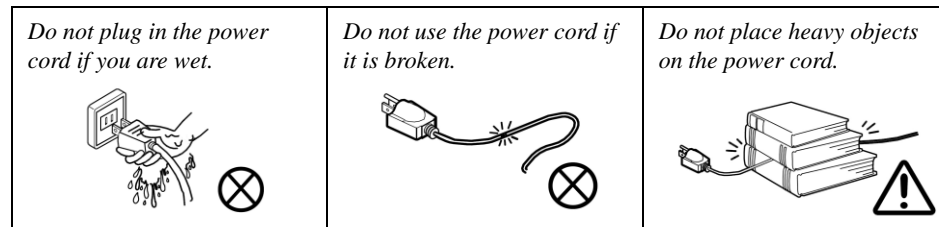

Power Safety Warning

Before you undertake any upgrade procedures, make sure that you have turned off the power, and disconnected all peripherals and cables (including telephone lines). It is advisable to also remove your battery in order to prevent accidentally turning the machine on.

Battery Precautions

- Only use batteries designed for this computer. The wrong battery type may explode, leak or damage the computer.
- Do not continue to use a battery that has been dropped, or that appears damaged (e.g. bent or twisted) in any way. Even if the computer continues to work with a damaged battery in place, it may cause circuit damage, which may possibly result in fire.
- Recharge the batteries using the notebook's system. Incorrect recharging may make the battery explode.
- Do not try to repair a battery pack. Refer any battery pack repair or replacement to your service representative or qualified service personnel.
- Keep children away from, and promptly dispose of a damaged battery. Always dispose of batteries carefully. Batteries may explode or leak if exposed to fire, or improperly handled or discarded.
- Keep the battery away from metal appliances.
- Affix tape to the battery contacts before disposing of the battery.
- Do not touch the battery contacts with your hands or metal objects.

Battery Guidelines

The following can also apply to any backup batteries you may have.

- If you do not use the battery for an extended period, then remove the battery from the computer for storage.
- Before removing the battery for storage charge it to 60% - 70%.
- Check stored batteries at least every 3 months and charge them to 60% - 70%.



Battery Disposal

The product that you have purchased contains a rechargeable battery. The battery is recyclable. At the end of its useful life, under various state and local laws, it may be illegal to dispose of this battery into the municipal waste stream. Check with your local solid waste officials for details in your area for recycling options or proper disposal.

Caution

Danger of explosion if battery is incorrectly replaced. Replace only with the same or equivalent type recommended by the manufacturer. Discard used battery according to the manufacturer's instructions.

Battery Level

Click the battery icon  in the taskbar to see the current battery level and charge status. A battery that drops below a level of 10% will not allow the computer to boot up. Make sure that any battery that drops below 10% is recharged within one week.

Related Documents

You may also need to consult the following manual for additional information:

User's Manual on CD/DVD

This describes the notebook PC's features and the procedures for operating the computer and its ROM-based setup program. It also describes the installation and operation of the utility programs provided with the notebook PC.

System Startup

1. Remove all packing materials.
2. Place the computer on a stable surface.
3. Insert the battery and make sure it is locked in position.
4. Securely attach any peripherals you want to use with the computer (e.g. keyboard and mouse) to their ports.
5. Attach the AC/DC adapter to the DC-In jack at the left of the computer, then plug the AC power cord into an outlet, and connect the AC power cord to the AC/DC adapter.
6. Use one hand to raise the lid/LCD to a comfortable viewing angle (do not exceed 135 degrees); use the other hand (as illustrated in Figure 1) to support the base of the computer (**Note: Never** lift the computer by the lid/LCD).
7. Press the power button to turn the computer "on".



Figure 1
Opening the Lid/LCD/
Computer with AC/DC
Adapter Plugged-In



Shut Down

Note that you should always shut your computer down by choosing the **Shut Down** command from the bottom right of the **Start** menu in **Windows**. This will help prevent hard disk or system problems.

Contents

Introduction	1-1	Part Lists	A-1
Overview	1-1	Part List Illustration Location	A-2
Specifications	1-2	Top	A-3
External Locator - Top View with LCD Panel Open	1-4	Bottom	A-4
External Locator - Front & Right Side Views	1-5	HDD	A-5
External Locator - Left Side & Rear View	1-6	DVD	A-6
External Locator - Bottom View	1-7	LCD	A-7
Mainboard Overview - Top (Key Parts)	1-8	Schematic Diagrams.....	B-1
Mainboard Overview - Bottom (Key Parts)	1-9	System Block Diagram	B-2
Mainboard Overview - Top (Connectors)	1-10	Processor 1/7	B-3
Mainboard Overview - Bottom (Connectors)	1-11	Processor 2/7	B-4
Disassembly	2-1	Processor 3/7	B-5
Overview	2-1	Processor 4/7	B-6
Maintenance Tools	2-2	Processor 5/7	B-7
Connections	2-2	Processor 6/7	B-8
Maintenance Precautions	2-3	Processor 7/7	B-9
Disassembly Steps	2-4	DDR3 SO-DIMM_0	B-10
Removing the Battery	2-5	DDR3 SO-DIMM_1	B-11
Removing and Installing the Hard Disk Drive	2-6	PS8625	B-12
Removing the System Memory (RAM)	2-8	LVDS, Inverter	B-13
Removing and Installing a Processor	2-10	HDMI	B-14
Removing the 3G Module	2-13	CRT	B-15
Removing the Wireless LAN Module	2-14	Lynx 1/9	B-16
Wireless LAN, Combo, 3G & LTE Module Cables	2-15	Lynx 2/9	B-17
Removing the Optical Device	2-16	Lynx 3/9	B-18
Removing the Keyboard	2-17	Lynx 4/9	B-19
Removing and Installing the Mainboard	2-18	Lynx 5/9	B-20
Removing the LCD	2-20	Lynx 6/9	B-21
Removing the Speaker	2-21	Lynx 7/9	B-22

Preface

Lynx 8/9	B-23
Lynx 9/9	B-24
Intel LAN i217LM	B-25
LAN Transformer	B-26
Card Reader RTS5229	B-27
USB Port, E-SATA	B-28
3G, HDD, ODD	B-29
WLAN, CCD, TPM	B-30
KBC-ITE IT8587	B-31
AUDIO CODEC ALC269	B-32
New Card, GSensor	B-33
Fan, TP, Connector	B-34
Docking Connector, COM Port	B-35
5VS, 3VS, 3.3VM, 5VM	B-36
1.05V Series	B-37
VDD3, VDD5	B-38
Power 1.5V, 1.35V, 0.75VS, 1.5VS	B-39
POWER V_CORE 1	B-40
AC IN, Charger	B-41
Audio Board	B-42
Power Switch & LID Board	B-43
CLICK BOARD	B-44
FINGERPRINT BOARD	B-45
Updating the FLASH ROM BIOS.....	C-1
Download the BIOS	C-1
Unzip the downloaded files to a bootable CD/DVD/ or	
USB Flash drive	C-1
Set the computer to boot from the external drive	C-1
Use the flash tools to update the BIOS	C-2
Restart the computer (booting from the HDD)	C-2

Chapter 1: Introduction

Overview

This manual covers the information you need to service or upgrade the **W25CSW** series notebook computer. Information about operating the computer (e.g. getting started, and the *Setup* utility) is in the *User's Manual*. Information about drivers (e.g. VGA & audio) is also found in the *User's Manual*. The manual is shipped with the computer.

Operating systems (e.g. *Windows 7*, etc.) have their own manuals as do application softwares (e.g. word processing and database programs). If you have questions about those programs, you should consult those manuals.

The **W25CSW** series notebook is designed to be upgradeable. See [Disassembly on page 2 - 1](#) for a detailed description of the upgrade procedures for each specific component. Please take note of the warning and safety information indicated by the “” symbol.

The balance of this chapter reviews the computer's technical specifications and features.

Specifications



Latest Specification Information

The specifications listed here are correct at the time of sending them to the press. Certain items (particularly processor types/speeds) may be changed, delayed or updated due to the manufacturer's release schedule. Check with your service center for more details.



CPU

The CPU is not a user serviceable part. Accessing the CPU in any way may violate your warranty.

Processor Options

Intel® Core™ i7 Processor

i7-4702MQ (2.20GHz)

6MB L3 Cache, **22nm**, DDR3L-1600MHz, TDP 37W

i7-4600M (2.90GHz)

4MB L3 Cache, **22nm**, DDR3L-1600MHz, TDP 37W

Intel® Core™ i5 Processor

i5-4330M (2.80GHz), i5-4300M (2.60GHz), i5-4200M (2.50GHz)

3MB L3 Cache, **22nm**, DDR3L-1600MHz, TDP 37W

Intel® Core™ i3 Processor

i3-4100M (2.50GHz), i3-4000M (2.40GHz)

3MB L3 Cache, **22nm**, DDR3L-1600MHz, TDP 37W

Intel® Pentium™ Processor

3550M (2.30GHz)

2MB L3 Cache, **22nm**, DDR3L-1600MHz, TDP 37W

Intel® Celeron™ Processor

2950M (2.00GHz)

2MB L3 Cache, **22nm**, DDR3L-1600MHz, TDP 37W

LCD

15.6" (39.62cm) HD/HD+/FHD

BIOS

AMI BIOS (One 96Mb SPI Flash ROM)

Core Logic

Intel® HM87 Chipset

Memory

Two 204 Pin SO-DIMM Sockets Supporting **DDR3L 1600MHz** Memory

Memory Expandable up to **16GB**

(The real memory operating frequency depends on the FSB of the processor.)

Storage

(**Factory Option**) One Changeable 12.7mm(h) Super Multi Optical Device Drive

One Changeable 2.5" 9.5mm/7.0mm (h) SATA HDD

(**Factory Option**) One mSATA Solid State Drive (SSD)

Video Adapter

Intel Integrated GPU

(*GPU is Dependent on Processor*)

Intel® HD Graphics 4600/Intel® HD Graphics

Dynamic Frequency (Intel Dynamic Video Memory Technology for up to **1.7GB**)

Microsoft DirectX®11 Compatible

Audio

High Definition Audio Compliant Interface

2 * Built-In Speakers

Built-In Microphone

Security

BIOS Password

Security (Kensington® Type) Lock Slot

Fingerprint Reader

TPM v1.2

Keyboard

Full-size "WinKey" keyboard (with numeric keypad)

Pointing Device

Built-in Touchpad (scrolling key functionality integrated)

Communication

Built-In Gigabit Ethernet LAN

(Factory Option) 1.0M HD PC Camera Module

(Factory Option) 3G Module

WLAN/ Bluetooth Half Mini-Card Modules:

(Factory Option) Intel® Wireless-N 7260 Wireless LAN (802.11b/g/n) + Bluetooth 4.0

(Factory Option) Intel® Wireless-N 3160 Wireless LAN (802.11a/c) + Bluetooth 4.0

(Factory Option) Third-Party Wireless LAN (802.11b/g/n) + Bluetooth 4.0

(Factory Option) Third-Party Wireless LAN (802.11b/g/n)

Interface

Three USB 3.0 Ports (Including one AC/DC Powered USB port)

One USB 2.0 Port

One eSATA Port

One HDMI-Out Port

One Headphone and S/PDIF Out Combo Jack

One Microphone-In Jack

One RJ-45 LAN Jack

One External Monitor Port

One ExpressCard/34(54) Slot

One DC-in Jack

One Docking Port

Card Reader

Embedded Multi-in-1 Push-Push Card Reader

MMC (MultiMedia Card) / RS MMC

SD (Secure Digital) / Mini SD / SDHC/ SDXC

MS (Memory Stick) / MS Pro / MS Duo

Mini Card Slots

Slot 1 for **WLAN** Module or **WLAN and Bluetooth** Combo Module

(Factory Option) Slot 2 for **3G** Module or mSATA **SSD**

Environmental Spec

Temperature

Operating: 5°C - 35°C

Non-Operating: -20°C - 60°C

Relative Humidity

Operating: 20% - 80%

Non-Operating: 10% - 90%

Power

Full Range AC/DC Adapter

AC Input: 100 - 240V, 50 - 60Hz

DC Output: 19V, 3.42A (**65W**)

6 Cell Smart Lithium-Ion Battery Pack, 62.16WH

Dimensions & Weight

374mm (w) * 250mm (d) * 35.5mm (h)

2.33kg with ODD & 62.16WH Battery

Introduction

External Locator - Top View with LCD Panel Open

Figure 1
Top View

1. PC Camera
(Optional)
2. *PC Camera LED
**When the PC camera is in use, the LED will be illuminated in red.*
3. LCD
4. Power Button
5. LED Indicators
6. Keyboard
7. Built-In Microphone
8. Touchpad & Buttons
9. Fingerprint Reader

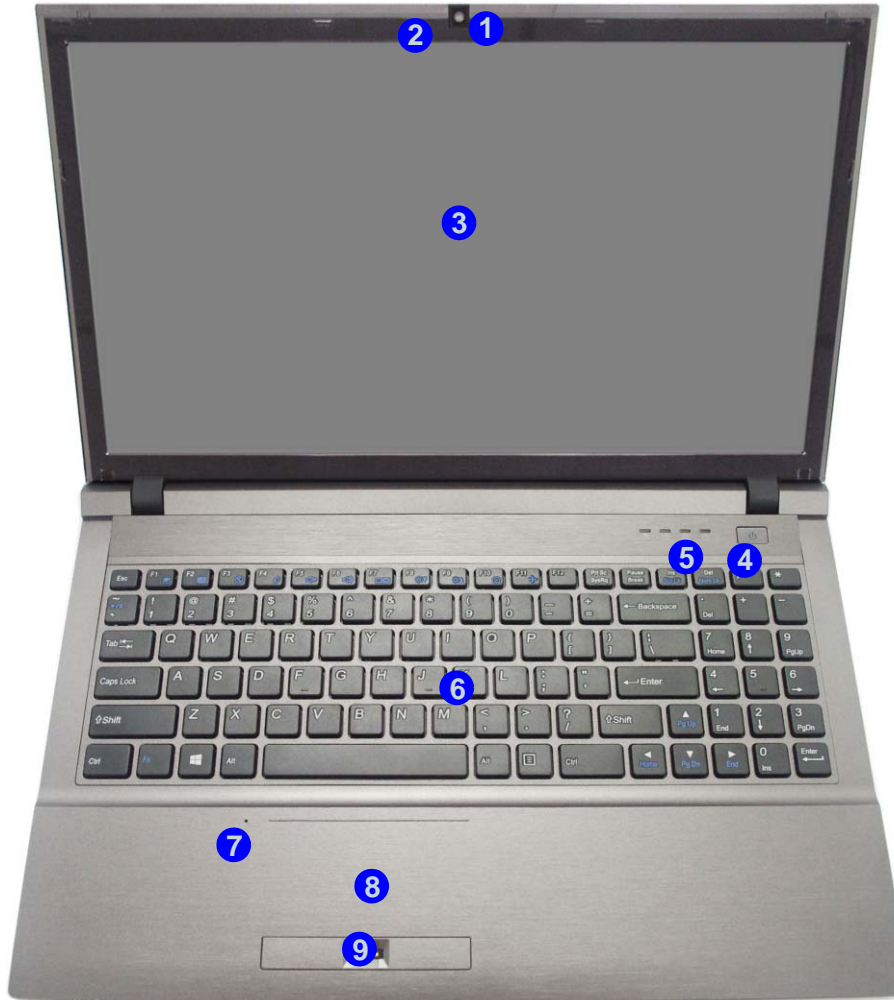

External Locator - Front & Right Side Views

FRONT VIEW



Figure 2
Front View

1. LED Indicator
2. Touchpad Switch

RIGHT SIDE VIEW



Figure 3
Right Side View

1. Microphone-In Jack
2. Headphone and S/PDIF Out Combo Jack
3. USB 2.0 Port
4. Optical Device Drive Bay
5. Emergency Eject Hole

Introduction

External Locator - Left Side & Rear View

Figure 4
Left Side View

1. DC-In Jack
2. External Monitor Port
3. RJ-45 LAN Jack
4. e-SATA Port
5. Vent
6. Powered USB 3.0 Port
7. 2 * USB 3.0 Ports
8. HDMI-Out Port
9. ExpressCard/54(34) Slot
10. Multi-in-1 Card Reader

LEFT SIDE VIEW

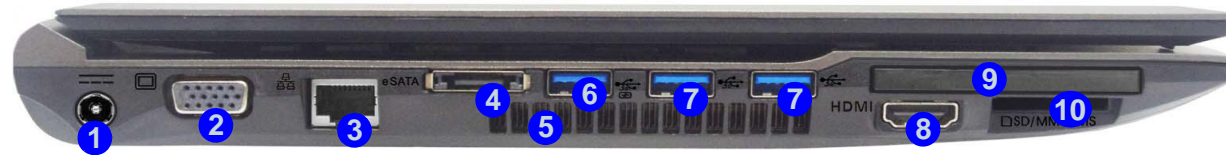

Figure 5
Rear View

1. Battery
2. Security Lock Slot

REAR VIEW



External Locator - Bottom View

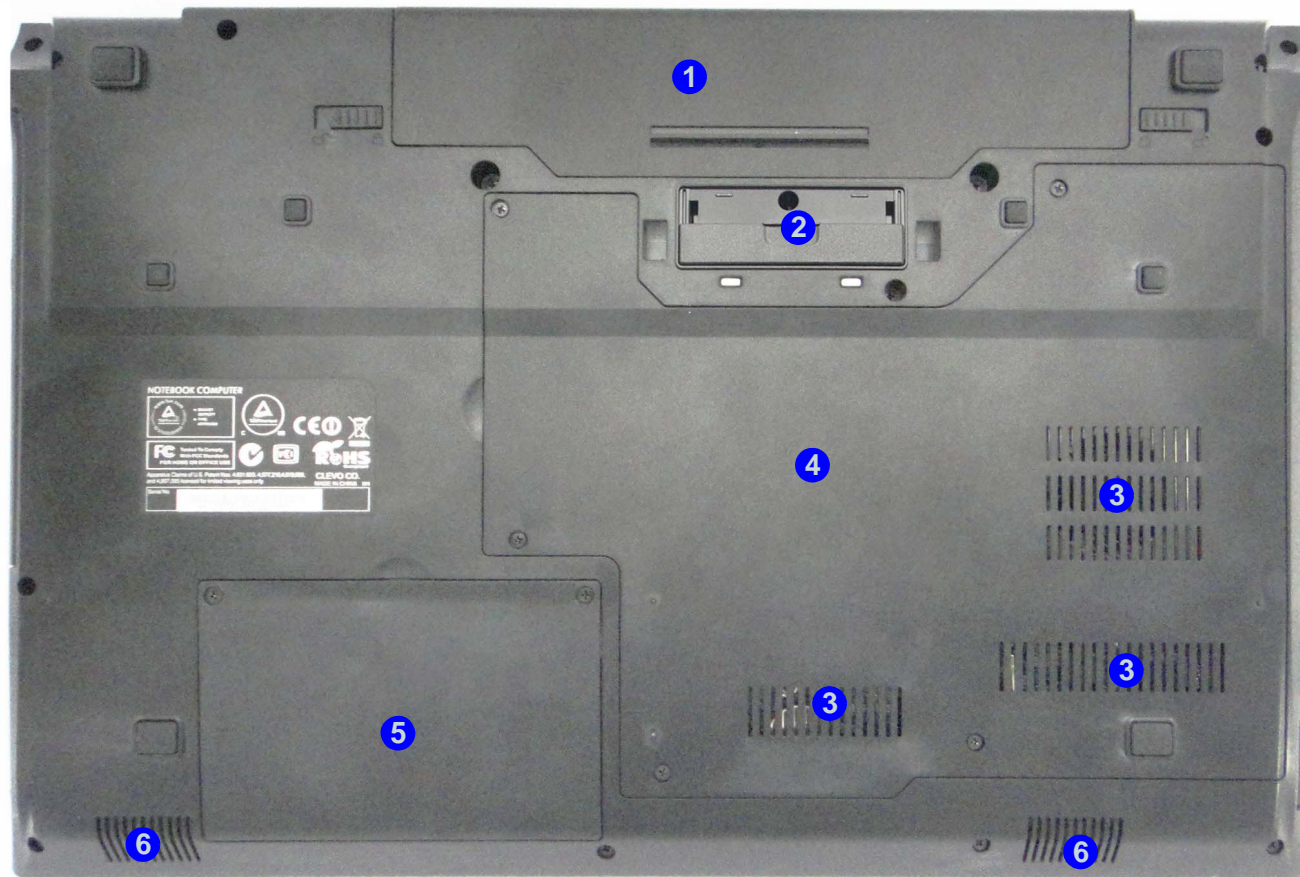

Figure 6
Bottom View

1. Battery
2. Docking Port
3. Vent
4. Component Bay Cover
5. Hard Disk Bay Cover
6. Speakers



Overheating

To prevent your computer from overheating, make sure nothing blocks any vent while the computer is in use.

Introduction

Figure 7
**Mainboard Top
Key Parts**

1. PI3L720ZHE
2. TUSB7320
3. ITE IT8518E

Mainboard Overview - Top (Key Parts)

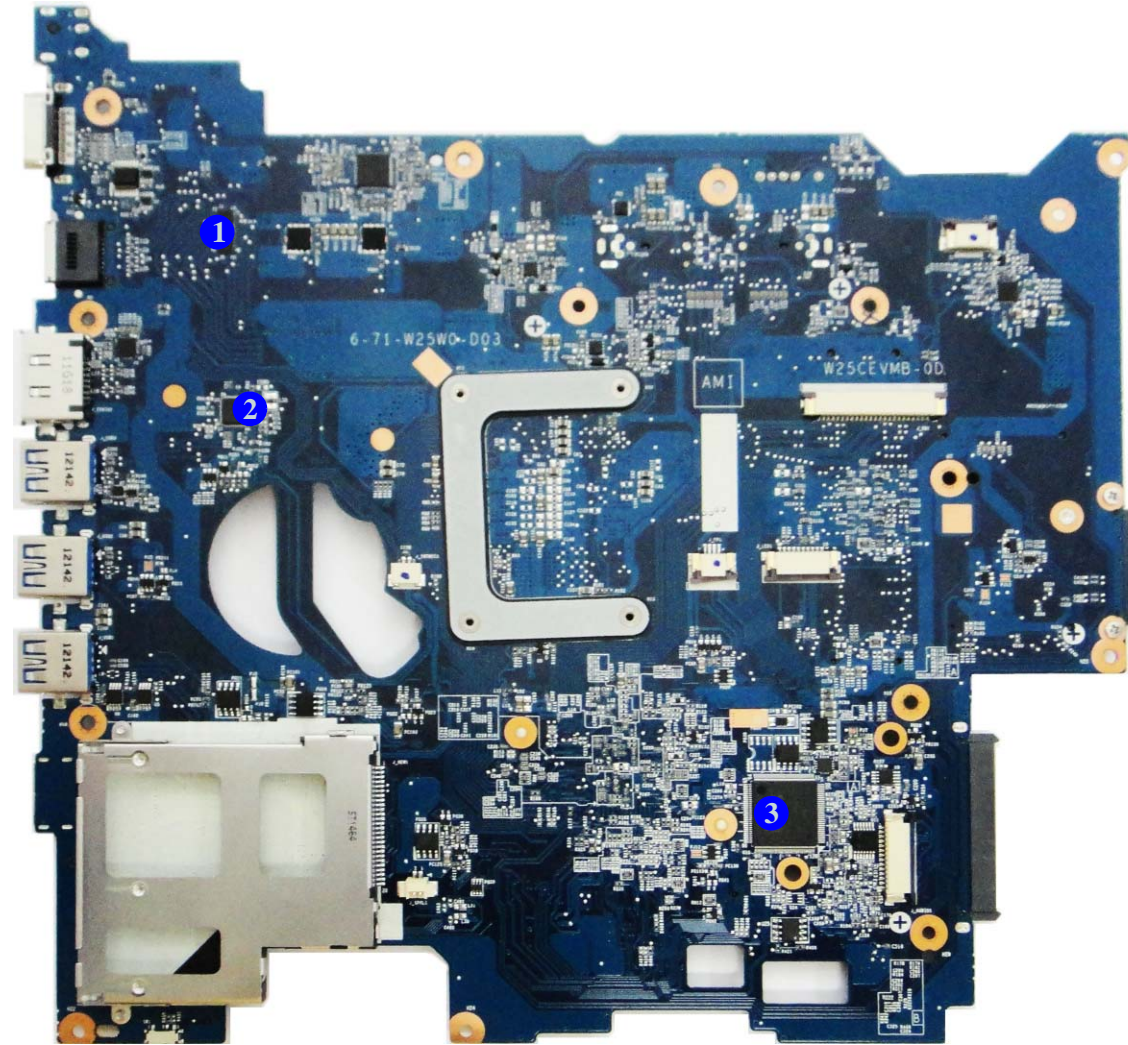

Mainboard Overview - Bottom (Key Parts)

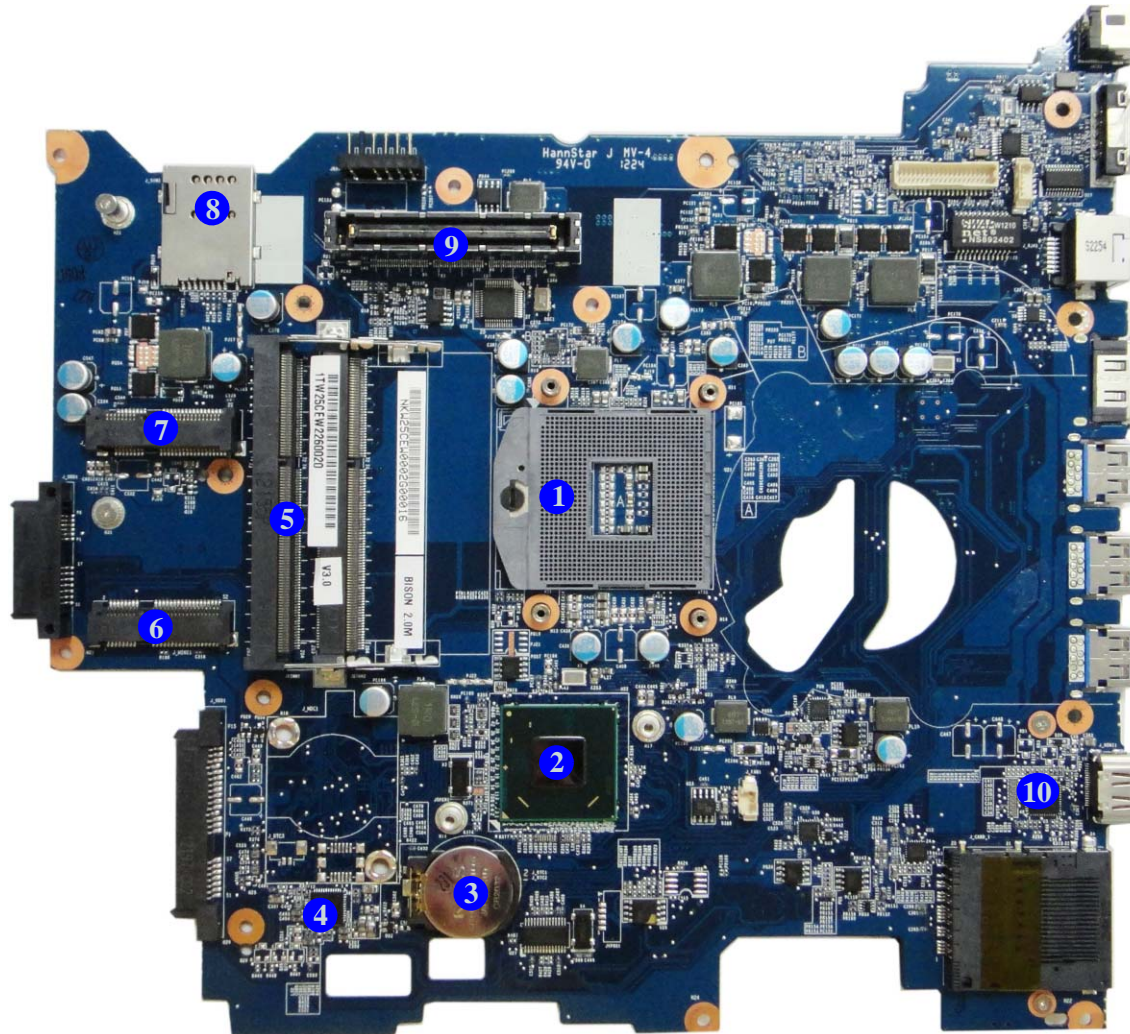

Figure 8
**Mainboard Bottom
Key Parts**

1. CPU Socket (no CPU installed)
2. Platform Controller Hub
3. CMOS Battery
4. Audio Codec VT1802P
5. Memory Slots DDR3 SO-DIMM
6. Mini-Card Connector (WLAN Module)
7. Mini-Card Connector (3G Module)
8. SIM LOCK
9. Docking Station Connector
10. Card Reader JMB369

Introduction

Figure 9
**Mainboard Top
Connectors**

1. e-SATA Port
2. Powered USB 3.0 Port
3. USB Port 3.0
4. Keyboard Cable Connector
5. Audio Board Connector
6. Touchpad Cable Connector

Mainboard Overview - Top (Connectors)



Mainboard Overview - Bottom (Connectors)

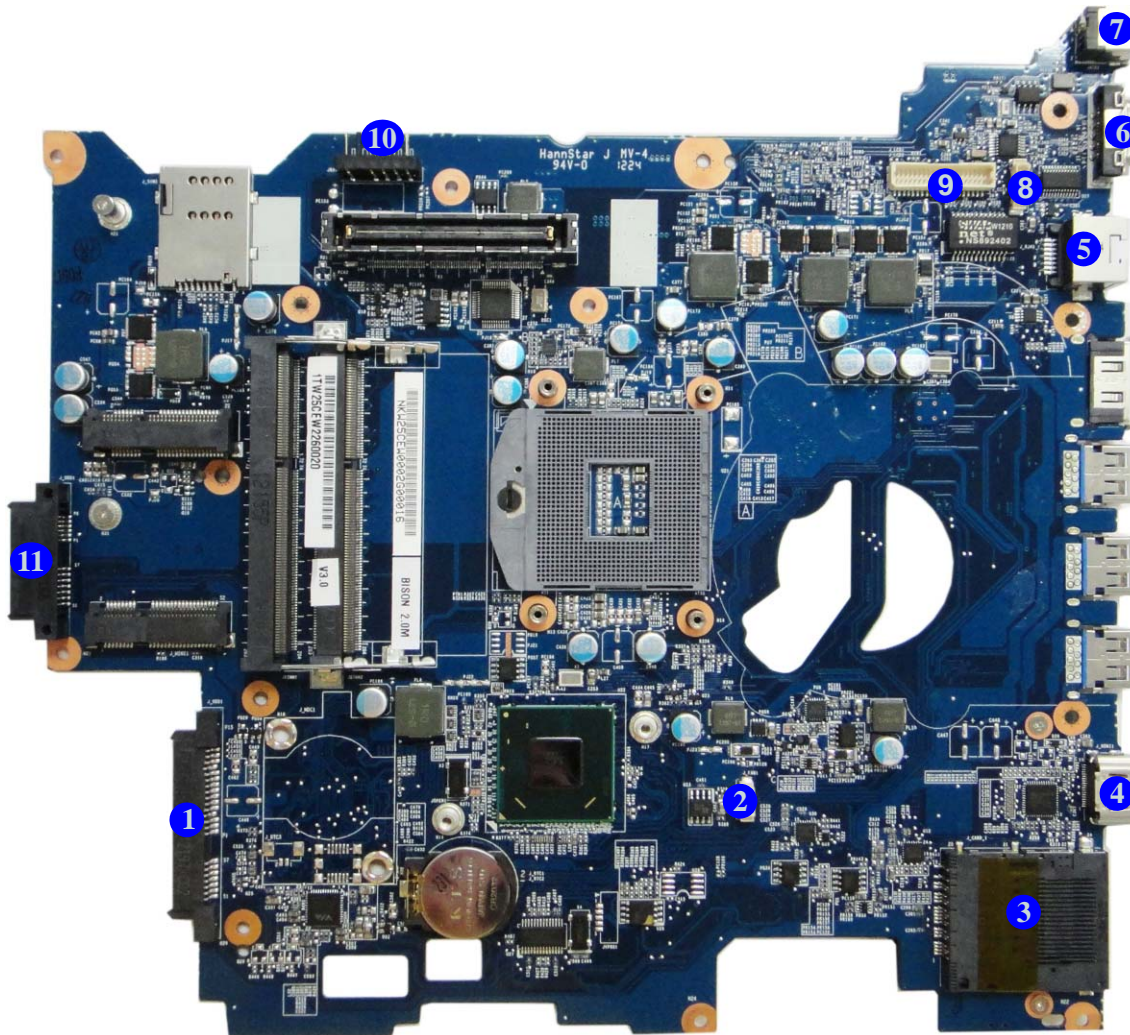

Figure 10
**Mainboard Bottom
Connectors**

1. HDD Connector
2. Fan Cable Connector
3. Multi-in-1 Card Reader
4. HDMI-Out Port
5. RJ-45 LAN Jack
6. External Monitor Port
7. DC-In Jack
8. Microphone Cable Connector
9. LVDS Cable Connector
10. Battery Connector
11. ODD Cable Connector

Chapter 2: Disassembly

Overview

This chapter provides step-by-step instructions for disassembling the *W25CSW* series notebook's parts and subsystems. When it comes to reassembly, reverse the procedures (unless otherwise indicated).

We suggest you completely review any procedure before you take the computer apart.

Procedures such as upgrading/replacing the RAM, optical device and hard disk are included in the User's Manual but are repeated here for your convenience.

To make the disassembly process easier each section may have a box in the page margin. Information contained under the figure # will give a synopsis of the sequence of procedures involved in the disassembly procedure. A box with a  lists the relevant parts you will have after the disassembly process is complete. **Note:** The parts listed will be for the disassembly procedure listed ONLY, and not any previous disassembly step(s) required. Refer to the part list for the previous disassembly procedure. The amount of screws you should be left with will be listed here also.

A box with a  will also provide any possible helpful information. A box with a  contains warnings.

An example of these types of boxes are shown in the sidebar.

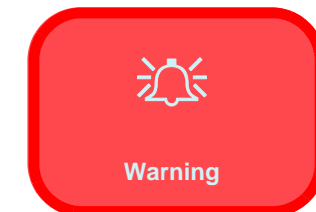
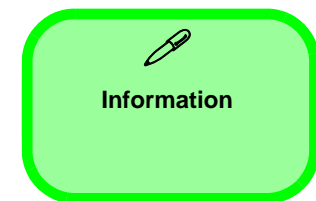

Disassembly

NOTE: All disassembly procedures assume that the system is turned **OFF**, and disconnected from any power supply (the battery is removed too).

Maintenance Tools

The following tools are recommended when working on the notebook PC:

- M3 Philips-head screwdriver
- M2.5 Philips-head screwdriver (magnetized)
- M2 Philips-head screwdriver
- Small flat-head screwdriver
- Pair of needle-nose pliers
- Anti-static wrist-strap

Connections

Connections within the computer are one of four types:

Locking collar sockets for ribbon connectors	To release these connectors, use a small flat-head screwdriver to gently pry the locking collar away from its base. When replacing the connection, make sure the connector is oriented in the same way. The pin1 side is usually not indicated.
Pressure sockets for multi-wire connectors	To release this connector type, grasp it at its head and gently rock it from side to side as you pull it out. Do not pull on the wires themselves. When replacing the connection, do not try to force it. The socket only fits one way.
Pressure sockets for ribbon connectors	To release these connectors, use a small pair of needle-nose pliers to gently lift the connector away from its socket. When replacing the connection, make sure the connector is oriented in the same way. The pin1 side is usually not indicated.
Board-to-board or multi-pin sockets	To separate the boards, gently rock them from side to side as you pull them apart. If the connection is very tight, use a small flat-head screwdriver - use just enough force to start.

Maintenance Precautions

The following precautions are a reminder. To avoid personal injury or damage to the computer while performing a removal and/or replacement job, take the following precautions:

1. **Don't drop it.** Perform your repairs and/or upgrades on a stable surface. If the computer falls, the case and other components could be damaged.
2. **Don't overheat it.** Note the proximity of any heating elements. Keep the computer out of direct sunlight.
3. **Avoid interference.** Note the proximity of any high capacity transformers, electric motors, and other strong magnetic fields. These can hinder proper performance and damage components and/or data. You should also monitor the position of magnetized tools (i.e. screwdrivers).
4. **Keep it dry.** This is an electrical appliance. If water or any other liquid gets into it, the computer could be badly damaged.
5. **Be careful with power.** Avoid accidental shocks, discharges or explosions.
 - Before removing or servicing any part from the computer, turn the computer off and detach any power supplies.
 - When you want to unplug the power cord or any cable/wire, be sure to disconnect it by the plug head. Do not pull on the wire.
6. **Peripherals** – Turn off and detach any peripherals.
7. **Beware of static discharge.** ICs, such as the CPU and main support chips, are vulnerable to static electricity. Before handling any part in the computer, discharge any static electricity inside the computer. When handling a printed circuit board, do not use gloves or other materials which allow static electricity buildup. We suggest that you use an anti-static wrist strap instead.
8. **Beware of corrosion.** As you perform your job, avoid touching any connector leads. Even the cleanest hands produce oils which can attract corrosive elements.
9. **Keep your work environment clean.** Tobacco smoke, dust or other air-borne particulate matter is often attracted to charged surfaces, reducing performance.
10. **Keep track of the components.** When removing or replacing any part, be careful not to leave small parts, such as screws, loose inside the computer.

Cleaning

Do not apply cleaner directly to the computer, use a soft clean cloth.

Do not use volatile (petroleum distillates) or abrasive cleaners on any part of the computer.



Power Safety Warning

Before you undertake any upgrade procedures, make sure that you have turned off the power, and disconnected all peripherals and cables (including telephone lines). It is advisable to also remove your battery in order to prevent accidentally turning the machine on.

Disassembly Steps

The following table lists the disassembly steps, and on which page to find the related information. **PLEASE PERFORM THE DISASSEMBLY STEPS IN THE ORDER INDICATED.**

To remove the Battery:

1. Remove the battery [page 2 - 5](#)

To remove the HDD:

1. Remove the battery [page 2 - 5](#)
2. Remove the HDD [page 2 - 6](#)

To remove the System Memory:

1. Remove the battery [page 2 - 5](#)
2. Remove the system memory [page 2 - 8](#)

To remove and install a Processor:

1. Remove the battery [page 2 - 5](#)
2. Remove the processor [page 2 - 10](#)
3. Install the processor [page 2 - 12](#)

To remove the 3G Module:

1. Remove the battery [page 2 - 5](#)
2. Remove the 3G module [page 2 - 13](#)

To remove the Wireless LAN Module:

1. Remove the battery [page 2 - 5](#)
2. Remove the WLAN module [page 2 - 14](#)

To remove the Optical Device:

1. Remove the battery [page 2 - 5](#)
2. Remove the ODD [page 2 - 16](#)

To remove the Keyboard:

1. Remove the battery [page 2 - 5](#)
2. Remove the keyboard [page 2 - 17](#)

To remove and install the Mainboard:

1. Remove the battery [page 2 - 5](#)
2. Remove the HDD [page 2 - 6](#)
3. Remove the system memory [page 2 - 8](#)
4. Remove the processor [page 2 - 10](#)
5. Remove the ODD [page 2 - 16](#)
6. Remove the keyboard [page 2 - 17](#)
7. Remove the mainboard [page 2 - 18](#)
8. Install the mainboard [page 2 - 19](#)

To remove the Speaker:

1. Remove the battery [page 2 - 5](#)
2. Remove the HDD [page 2 - 6](#)
3. Remove the system memory [page 2 - 8](#)
4. Remove the processor [page 2 - 10](#)
5. Remove the ODD [page 2 - 16](#)
6. Remove the keyboard [page 2 - 17](#)
7. Remove the mainboard [page 2 - 18](#)
8. Remove the speaker [page 2 - 21](#)

Removing the Battery

1. Turn the computer **off**, and turn it over.
2. Slide the latch **1** in the direction of the arrow (*Figure 1a*).
3. Slide the latch **2** in the direction of the arrow, and hold it in place (*Figure 1a*).
4. Slide the battery **3** in the direction of the arrow **4** (*Figure 1b*).
5. Make sure the latch **5** is in the unlock position, and slide the battery into the bay until it locks into position. Make sure both locks are locked after the battery is in the bay.

Figure 1
Battery Removal

- a. Slide the latch and hold it in place.
- b. Slide the battery out.
- c. Slide the battery in.

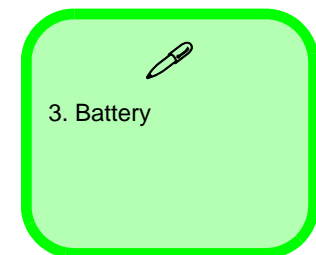
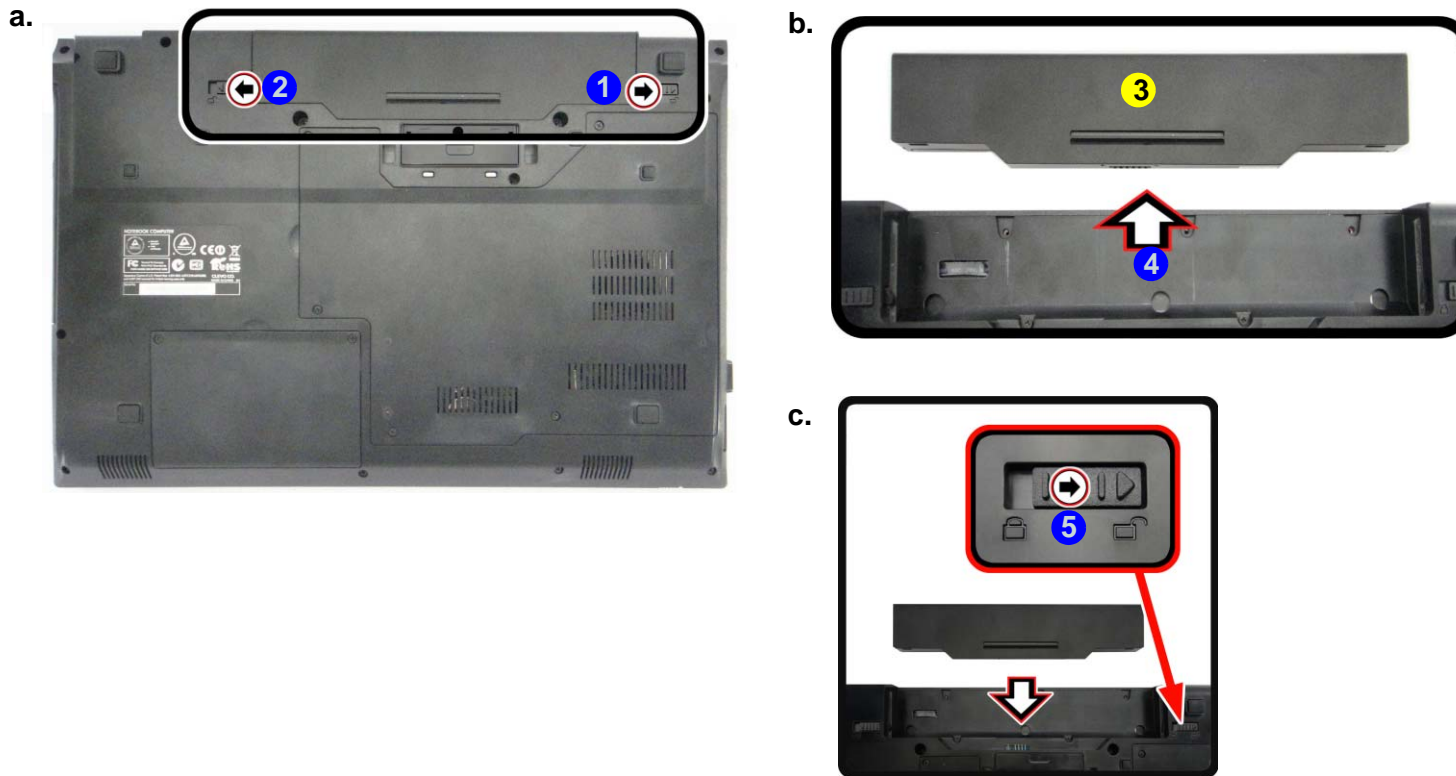

Disassembly

Figure 2
**HDD Assembly
Removal**

- Remove the screws.
- Remove the hard disk bay cover.

Removing and Installing the Hard Disk Drive

Hdd Removal Procedure

The hard disk drive can be taken out to accommodate other 2.5" serial (SATA) hard disk drives with a height of 9.5mm (h). Follow your operating system's installation instructions, and install all necessary drivers and utilities (as outlined in **Chapter 4 of the User's Manual**) when setting up a new hard disk.

Hard Disk Upgrade Process

- Turn **off** the computer, and remove the battery ([page 2 - 5](#)).
- Remove the screws ① - ②.
- Lift the hard disk bay cover up from point ③.
- Remove the hard disk bay cover ④ from the computer.

HDD System Warning

New HDD's are blank. Before you begin make sure:

You have backed up any data you want to keep from your old HDD.

You have all the CD-ROMs and FDDs required to install your operating system and programs.

If you have access to the internet, download the latest application and hardware driver updates for the operating system you plan to install. Copy these to a removable medium.

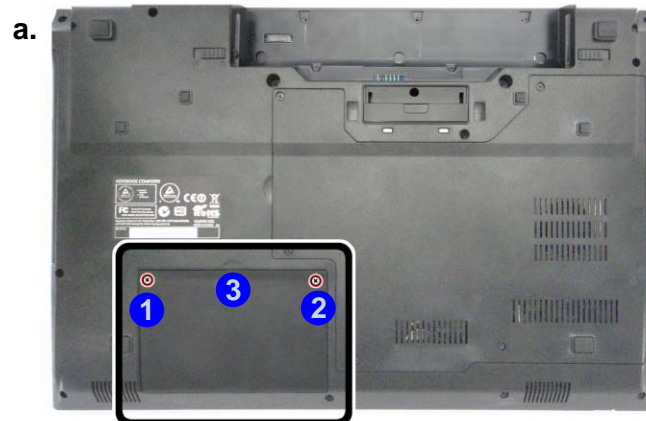

4. Hard Disk Bay Cover

- 2 Screws

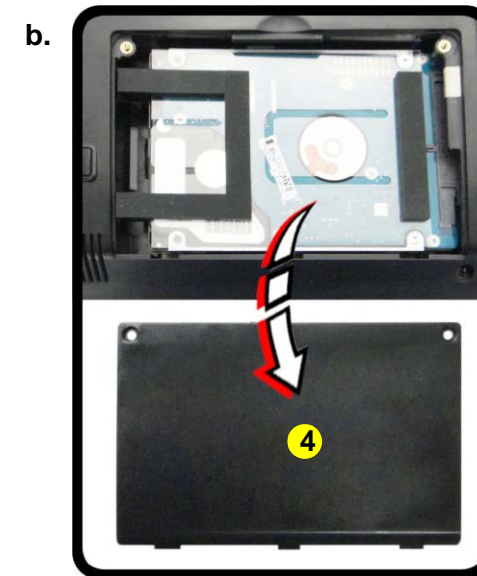

5. Raise the plastic tab 5.
6. Slide the hard disk assembly in the direction of arrow 6 (Figure 3d).
7. Remove the HDD assembly 7 from the bay.
8. Remove the screws 8 & 9 and the adhesive cover 10 from the hard disk 11 (Figure 3f).
9. Reverse the process to install a new hard disk drive.
10. Replace the hard disk bay cover and screws.

Figure 3
HDD Assembly
Removal (cont'd.)

- c. Raise the plastic tab.
- d. Grip the tab and slide the HDD assembly in the direction of the arrow.
- e. Lift the HDD assembly out of the bay.
- f. Remove the screws and mylar cover.

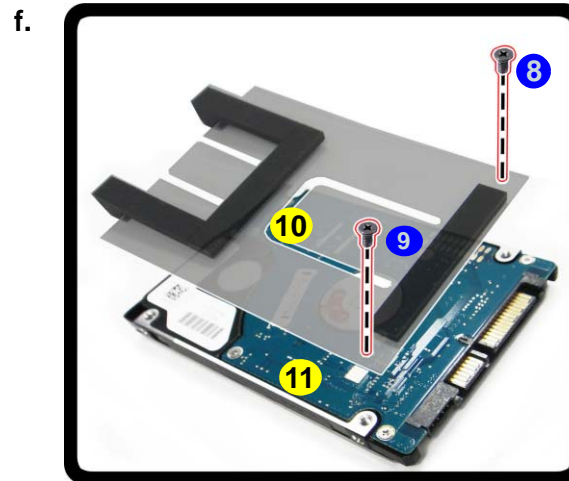
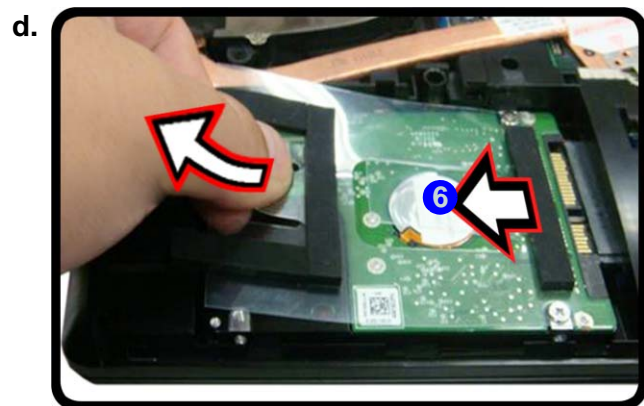
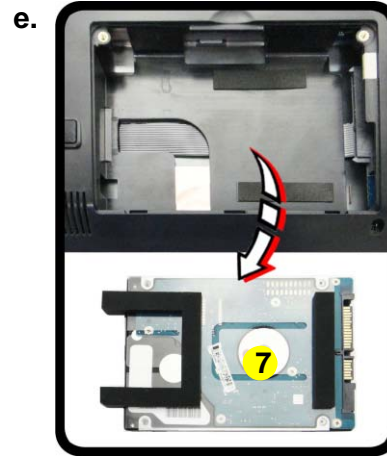
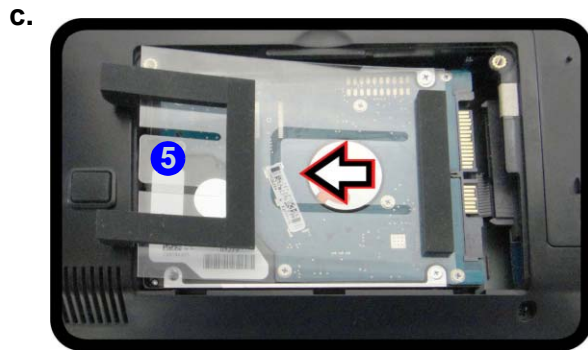



7. HDD Assembly
10. Adhesive Cover
11. HDD

- 2 Screws

Disassembly

Figure 4
RAM Module Removal

- a. Remove the screws.
- b. Remove the cover.

Removing the System Memory (RAM)

The computer has two memory sockets for 204 pin Small Outline Dual In-line Memory Modules (SO-DIMM) supporting DDR3L Up to 1600 MHz. The main memory can be expanded up to 16GB. The SO-DIMM modules supported are 1024MB and 2048MB **DDR3L** Modules. The total memory size is automatically detected by the POST routine once you turn on your computer.

Memory Upgrade Process

1. Turn **off** the computer, turn it over to remove the battery ([page 2 - 5](#)).
2. Locate the component bay cover and remove screws **1** - **5**.
3. Carefully remove the component bay cover **6**.

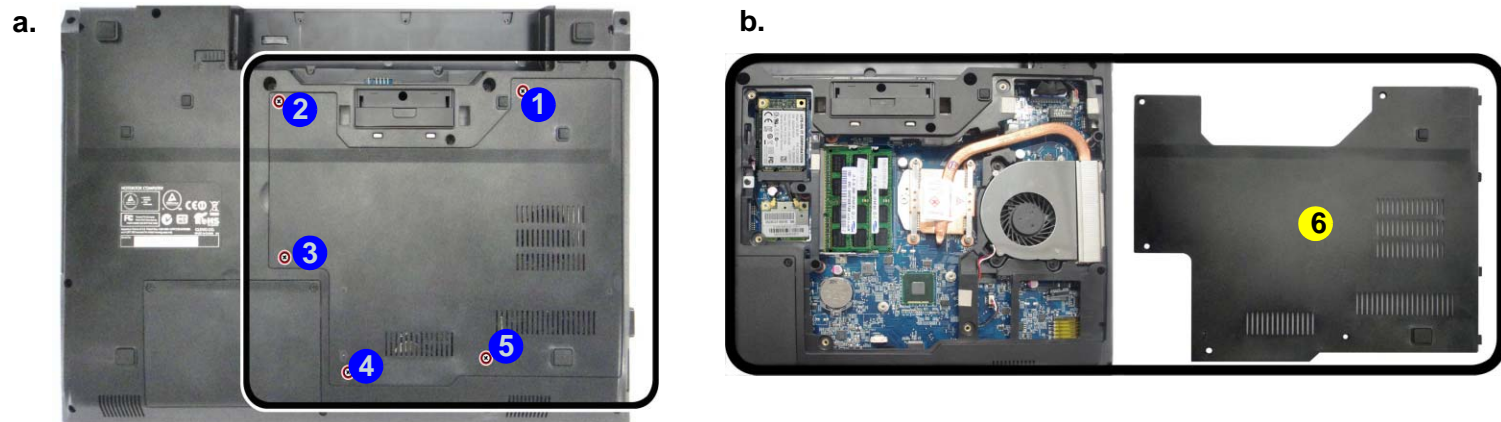

6. Component Bay Cover

- 5 Screws

- The RAM modules will be visible at point **7** on the mainboard.
- Gently pull the two release latches (**8** & **9**) on the sides of the memory socket in the direction indicated by the arrows (**Figure 5b**). The RAM module **10** will pop-up (**Figure 5c**), and you can then remove it.
- Pull the latches to release the second module if necessary.
- Insert a new module holding it at about a 30° angle and fit the connectors firmly into the memory slot.
- The module will only fit one way as defined by its pin alignment. Make sure the module is seated as far into the slot as it will go. **DO NOT FORCE IT**; it should fit without much pressure.
- Press the module in and down towards the mainboard until the slot levers click into place to secure the module.
- Replace the component bay cover (see [page 2 - 6](#)).
- Restart the computer to allow the BIOS to register the new memory configuration as it starts up.

Figure 5
RAM Module Removal (cont'd)

- The RAM modules will be visible at point **1** on the mainboard.
- Pull the release latches.
- Remove the module.

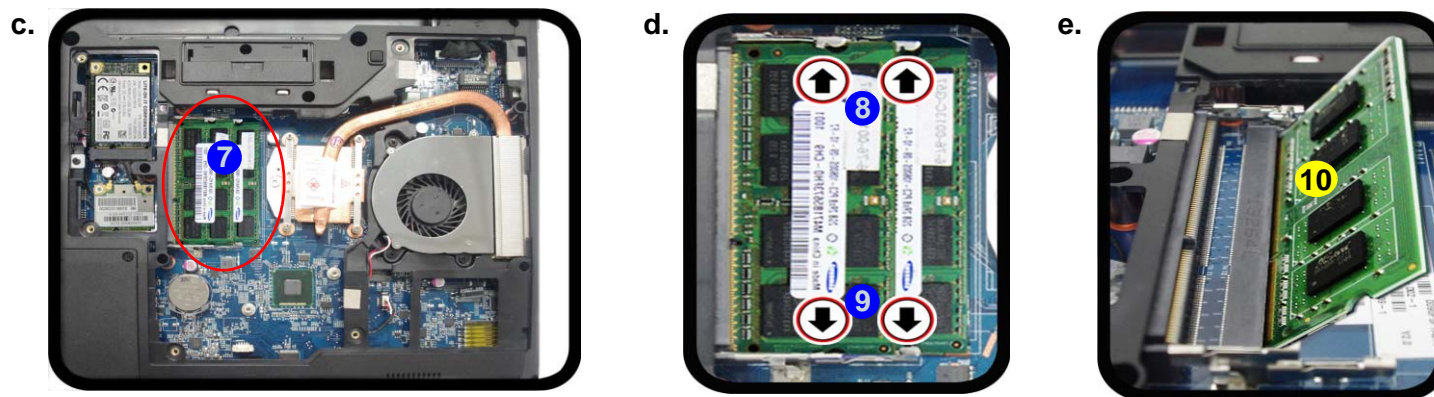

Contact Warning

Be careful not to touch the metal pins on the module's connecting edge. Even the cleanest hands have oils which can attract particles, and degrade the module's performance.



10. RAM Modules

Removing and Installing a Processor

Processor Removal Procedure

Figure 6
Processor Removal

1. Turn off the computer, turn it over, and remove the battery (page 2 - 5) and the component bay cover (page 2 - 8).
 2. The CPU heat sink will be visible at point **A** (Figure 6a).
 3. Carefully disconnect the cable **B**, and then remove the screws **C** - **E** (Figure 9b).
 4. Remove the fan **F**.
 5. Loosen the CPU heat sink screws in the order **4**, **3**, **2** & **1** (the reverse order as indicated on the label Figure 6d).
 6. Grip the heat sink tab **5** and carefully raise the heat sink **6** up off the computer (Figure 6e).
- a. The CPU heat sink will be visible at point **A**.
- b. Disconnect the cable and remove the screws.
- c. Remove the fan.
- d. Remove the screws from the CPU heatsink.
- e. Grip the heat sink tab and carefully lift the heat sink up and off the computer.

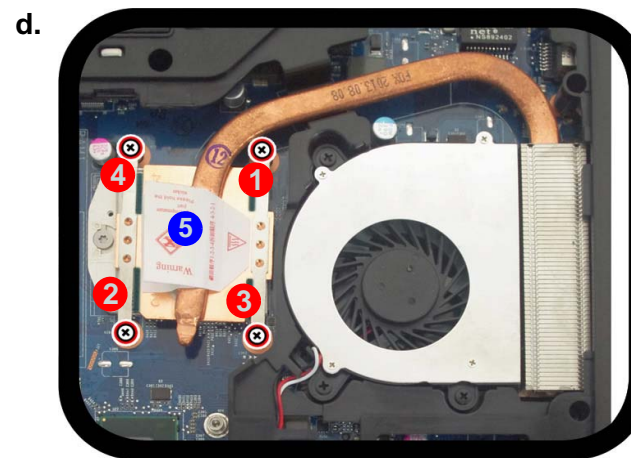
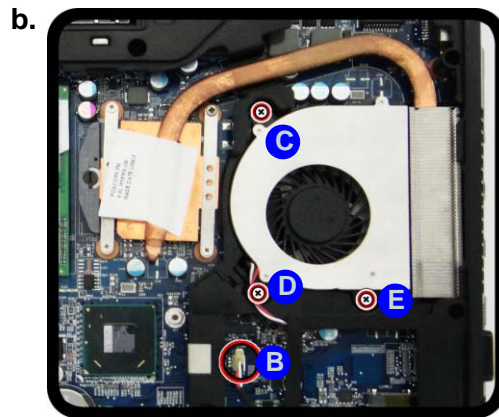
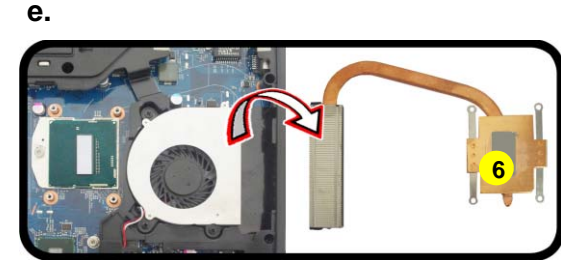
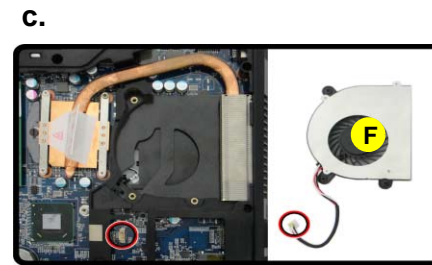



F. Fan
6. Heat Sink

- 7 Screws

- Turn the release latch **7** towards the unlock symbol  to release the CPU (*Figure 7d*).
- Carefully (it may be hot) lift the CPU **8** up and out of the socket (*Figure 7e*).
- Reverse the process to install a new CPU.
- When re-inserting the CPU, pay careful attention to the pin alignment, it will fit only one way (DO NOT FORCE IT!).

f.

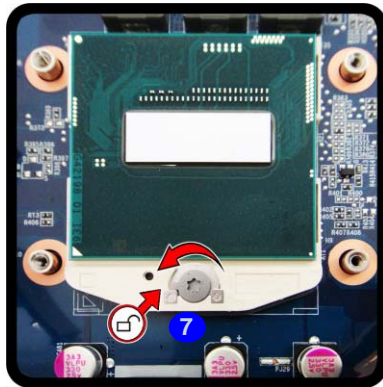

Unlock

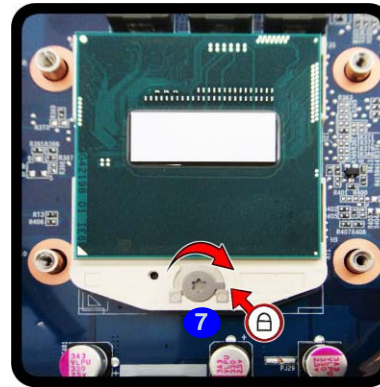

Lock

g.

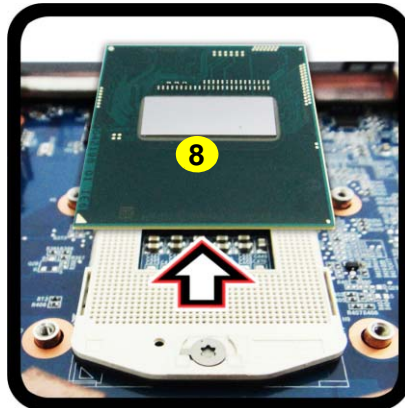

Caution

The heat sink, and CPU area in general, contains parts which are subject to high temperatures. Allow the area time to cool before removing these parts.



8. CPU

- Figure 7*
Processor Removal (cont'd)
- Turn the release latch to unlock the CPU.
 - Lift the CPU out of the socket.

Disassembly

Figure 8
Processor Installation

- Insert the CPU.
- Turn the release latch towards the lock symbol.
- Insert the heat sink and tighten the screws.

Processor Installation Procedure

- Insert the CPU **A** (*Figure 8a*), pay careful attention to the pin alignment, it will fit only one way (DO NOT FORCE IT!), and turn the release latch **B** towards the lock symbol  (*Figure 8b*).
- Insert the heat sink **C** and tighten the CPU heat sink screws in the order **1**, **2**, **3** & **4** (the order as indicated on the label and *Figure 8c*).
- Replace the component bay cover.

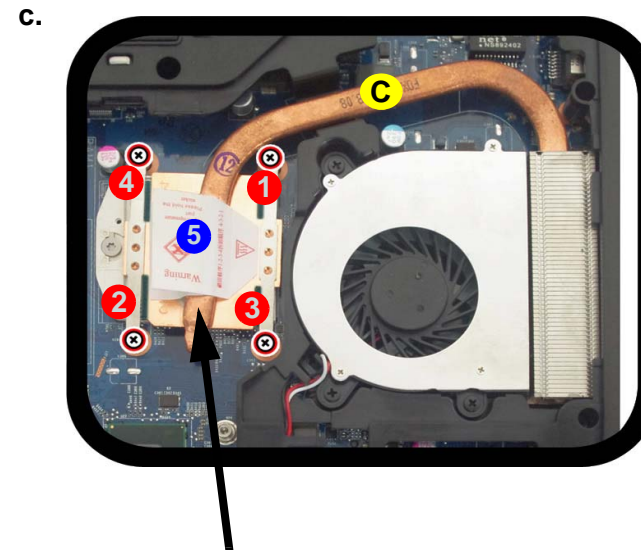
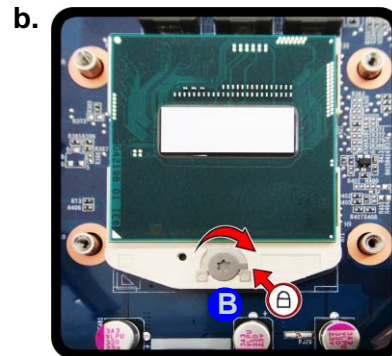
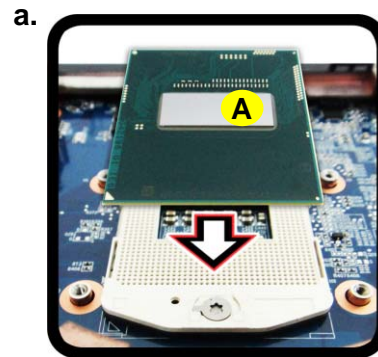

Note:
Tighten the screws
in the order as indicated
on the label.



A. CPU
C. Heat Sink

- 3 Screws

Removing the 3G Module

1. Turn off the computer, turn it over, and remove the battery ([page 2 - 5](#)) and the component bay cover ([page 2 - 8](#)).
2. Carefully disconnect the cables **1** & **2**, and then remove the screw **3** ([Figure 9a](#)).
3. The 3G module **4** will pop-up, and you can remove it from the computer ([Figure 9b](#)).



Figure 9
3G Module Removal

- a. Disconnect the cables and remove the screw.
- b. The module will pop-up.
- c. Remove the 3G module.

Note: Make sure you reconnect the antenna cable to socket.

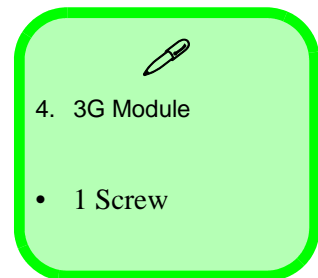

Disassembly

Figure 10
**Wireless LAN
 Module Removal**

- Disconnect the cables and remove the screw.
- The WLAN module will pop up.
- Remove the WLAN module.

Note: Make sure you reconnect the antenna cable to the “1 + 2” socket (*Figure 10b*).

4. Wireless LAN Module

- 1 Screw

Removing the Wireless LAN Module

- Turn **off** the computer, turn it over, and remove the battery (*page 2 - 5*) and the component bay cover (*page 2 - 8*).
- Carefully disconnect the cables **1** - **2**, and then remove the screw **3** (*Figure 10a*).
- The Wireless LAN module **4** (*Figure 10b*) will pop-up, and you can remove it from the computer.

a.

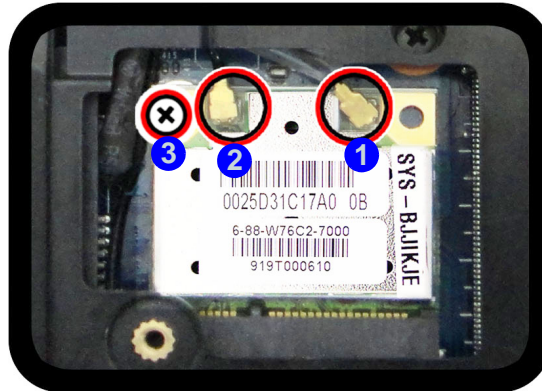

b.



c.

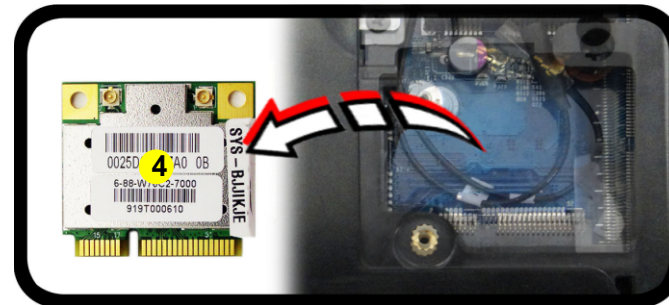

Wireless LAN, Combo, 3G & LTE Module Cables

Note that the cables for connecting to the antennae on WLAN, WLAN & Bluetooth Combo, 3G and LTE modules are not labelled. The cables/covers (each cable will have either a black or transparent cable cover) are color coded for identification as outlined in the table below.

Module Type	Antenna Type	Cable Color	Cable Cover Type
WLAN/WLAN & Bluetooth Combo	WM 1	Black	Transparent
	WM 2	Gray	
	WM 3	White	
LTE Broadband	LTE 1	Black	Black
	LTE 2	Gray	
3G Broadband	3G 1	Black	Black
	3G 2	Gray	

Cable 1 is usually connected to antenna 1 (Main) on the module, and cable 2 to antenna 2 (Aux).

Disassembly

Figure 11
ODD Removal

- Remove the screw.
- Push the optical device out of the computer.

Removing the Optical Device

- Turn **off** the computer, turn it over, and remove the battery ([page 2 - 5](#)) and the component bay cover ([page 2 - 8](#)).
- Remove the screw at point **1**, and use a screwdriver to carefully push out the optical device at point **2**.
- Push the optical device drive **3** out of the bay and reverse the process to install the new device.

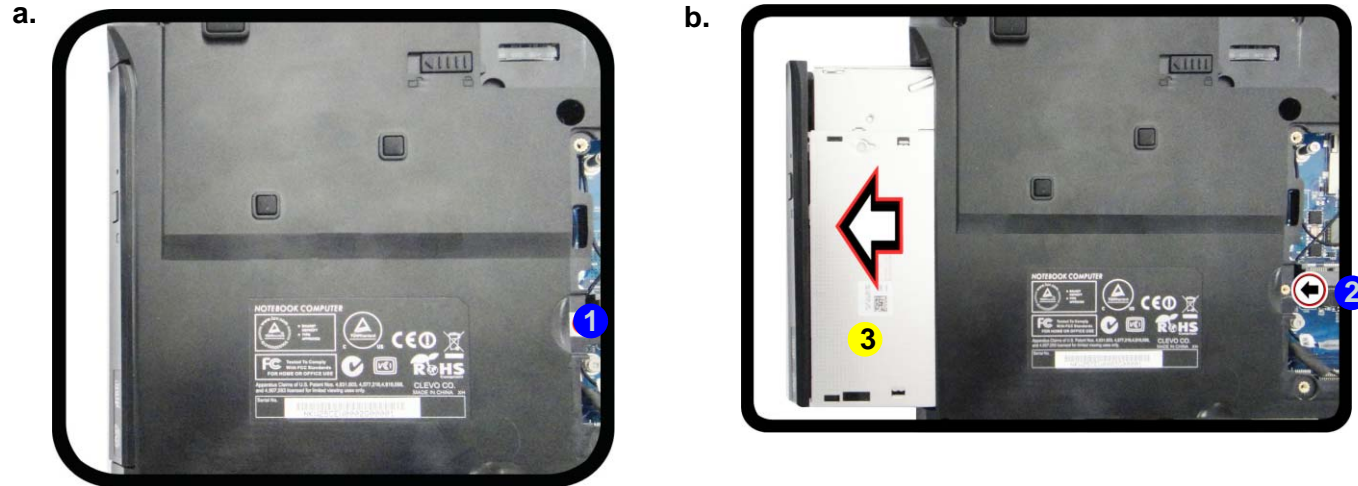

3. Optical Device

- 1 Screws

Removing the Keyboard

1. Turn **off** the computer, remove the battery ([page 2 - 5](#)), and the component bay cover ([page 2 - 8](#)).
2. Remove screws **1** - **2** from the bottom of the computer and carefully push out at point **3**.
3. Lift up the center cover module **4** and remove screws **5** - **9** from the keyboard ([Figure 12b](#)).
4. Carefully raise the keyboard up, being careful not to bend the keyboard ribbon cable **10**.
5. Disconnect the keyboard ribbon cable **10** from the locking collar socket **11** ([Figure 12c](#)).
6. Carefully lift up the keyboard **12** off the computer ([Figure 12d](#)).
7. Reverse the process to replace the keyboard (make sure to reconnect the keyboard cable).

a.

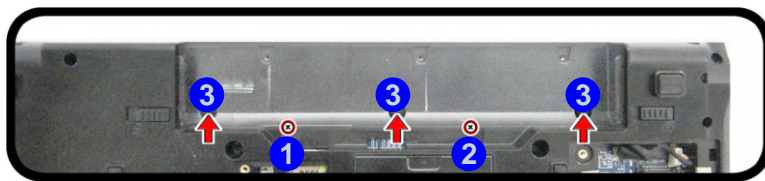

b.



c.



d.

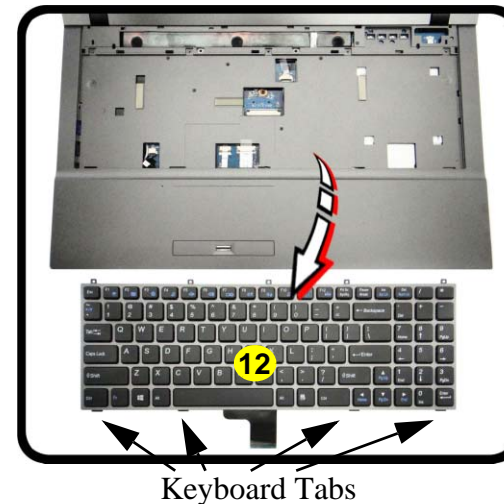

Figure 12

Keyboard Removal

- a. Remove screws from the bottom of the computer.
- b. Lift the center cover module and remove screws from the keyboard.
- c. Carefully lift the keyboard up and disconnect the keyboard ribbon cable from the locking collar socket.
- d. Remove the keyboard.



Re-Inserting the Keyboard

When re-inserting the keyboard firstly align the **four** keyboard tabs at the bottom ([Figure 12e](#)) at the bottom of the keyboard with the slots in the case.



- 4. Center Cover module
- 12. Keyboard

- 7 Screws

Figure 13
Mainboard Module Removal

- Separate the top and bottom case.
- Lift the top case.
- Remove the screws.
- Remove the mainboard.

Removing and Installing the Mainboard

Mainboard Removal Procedure

- Turn **off** the computer, remove the battery ([page 2 - 5](#)), HDD ([page 2 - 6](#)), RAM ([page 2 - 8](#)), CPU ([page 2 - 10](#)), ODD ([page 2 - 16](#)), and keyboard ([page 2 - 17](#)).
- Carefully separate the top and bottom case at point **1** and slide along the direction of the arrows **2** & **3** ([Figure 13a](#)).
- Lift the top case **4** from the bottom case of the computer ([Figure 13b](#)).
- Remove screws **5** - **7** ([Figure 13c](#)) on the mainboard from the computer.
- The mainboard **8** ([Figure 13d](#)) can be removed from the computer.

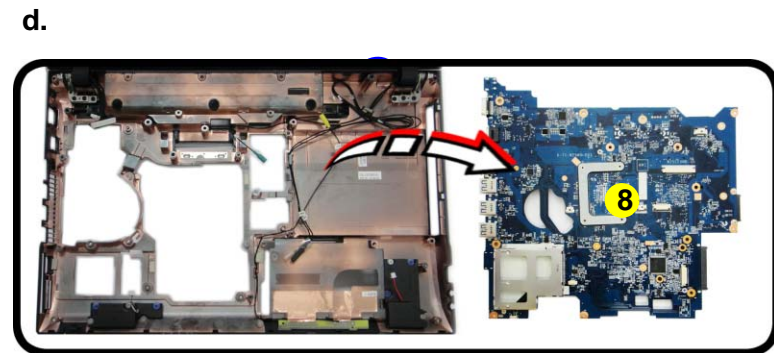
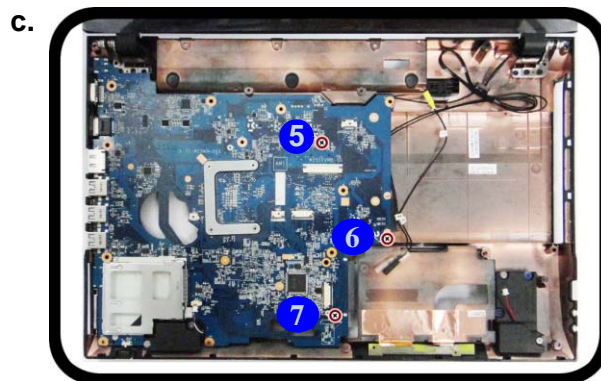
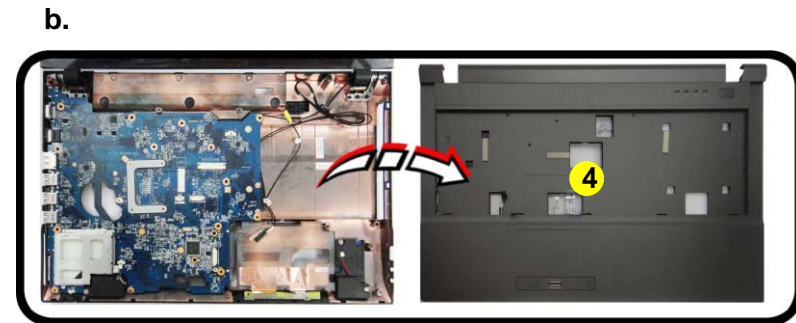
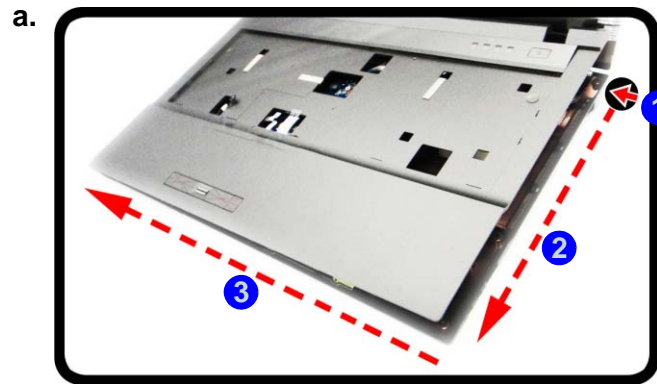

- 4. Top Case Module
- 8. Mainboard
- 3 Screws

Mainboard Installation Procedure

1. Insert the mainboard **1** by holding it at an angle and making sure that the ports are aligned with the bottom case (**Figure 14a**).
2. Tighten the screws **2** - **4** (**Figure 14b**) on the mainboard.
3. Make sure that the mainboard switch **5** is aligned with the WLAN knob slot **6** (**Figure 14c**).
4. Replace the keyboard (**page 2 - 17**), ODD (**page 2 - 16**), CPU (**page 2 - 10**), RAM (**page 2 - 8**), HDD (**page 2 - 6**), and battery (**page 2 - 5**).

Figure 14
Mainboard Module Installation

- a. Insert the mainboard.
- b. Tighten the screws.
- c. Align the mainboard switch with the WLAN slot.

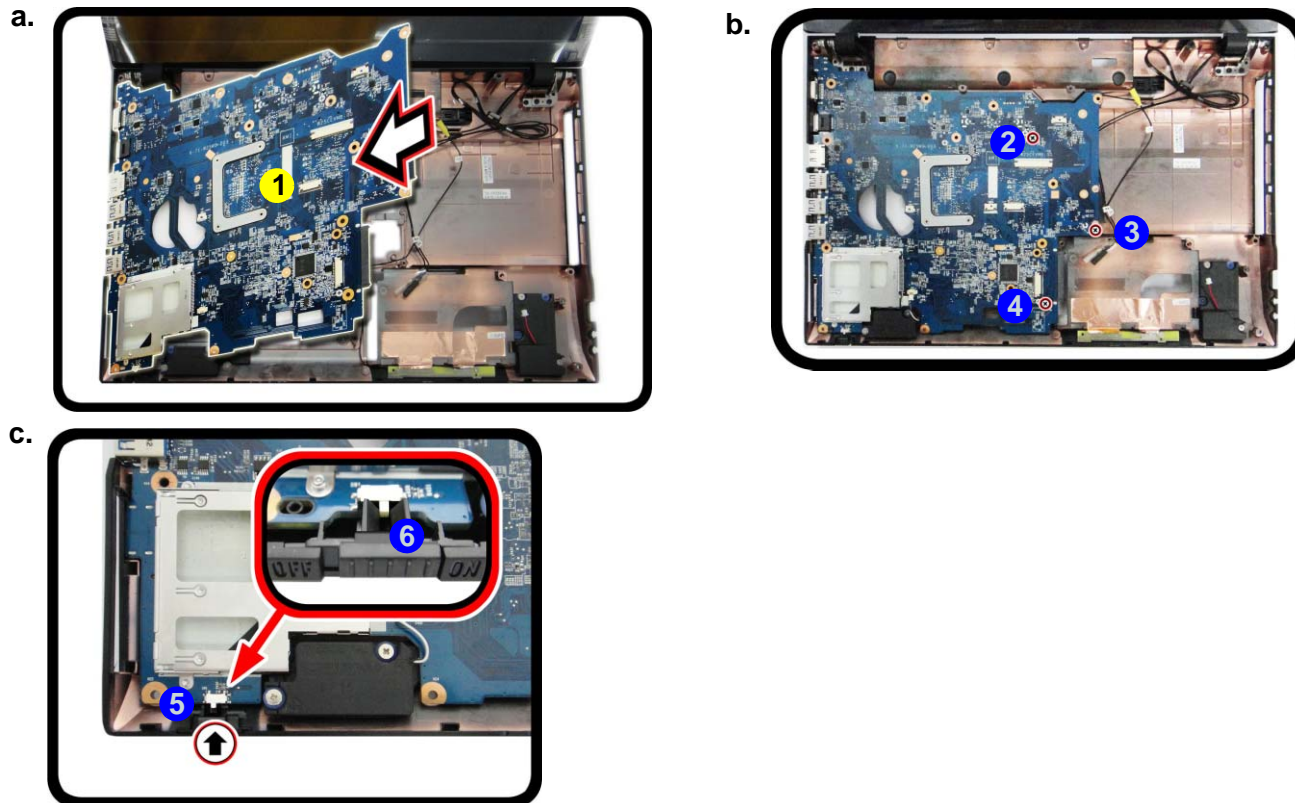



- 1. Mainboard
- 3 Screws

Disassembly

Figure 15
LCD Removal

- Remove the screws.
- Separate the LCD and bottom case.

Removing the LCD

- Turn **off** the computer, remove the battery ([page 2 - 5](#)), HDD ([page 2 - 6](#)), RAM ([page 2 - 8](#)), CPU ([page 2 - 10](#)), and keyboard ([page 2 - 17](#)).
- Carefully remove screws **1** - **4** ([Figure 15a](#)).
- Separate the LCD **5** and bottom case **6** of the computer ([Figure 15b](#)).

a.

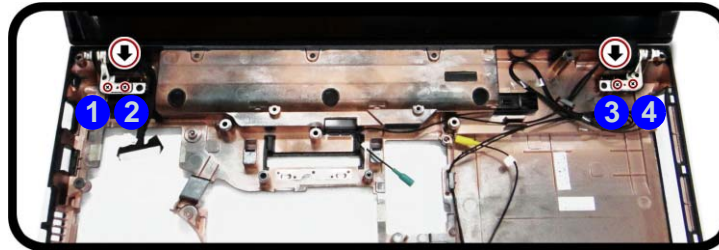

b.

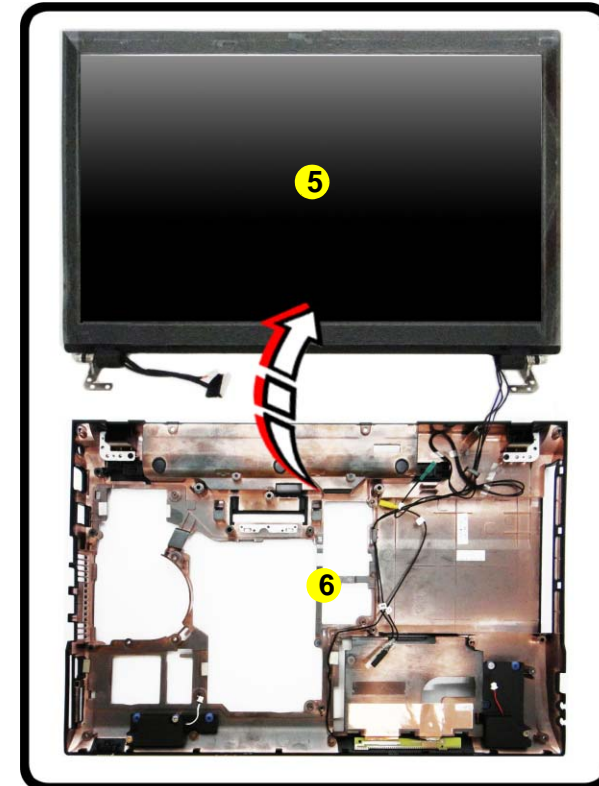

- LCD
- Bottom Case

- 4 Screws

Removing the Speaker

1. Turn **off** the computer, remove the battery ([page 2 - 5](#)), component bay cover ([page 2 - 8](#)), keyboard ([page 2 - 17](#)) and mainboard ([page 2 - 18](#)).
2. The speaker module will be visible at point **1** on the mainboard ([Figure 16a](#)).
3. Carefully remove the screws **2** - **3** ([Figure 16b](#)).
4. The speaker module **4** ([Figure 16c](#)) can be removed from the bottom case.

Figure 16
Speaker Module Removal

- a. Locate the speaker.
- b. Remove the screws.
- c. Remove the speaker.

a.

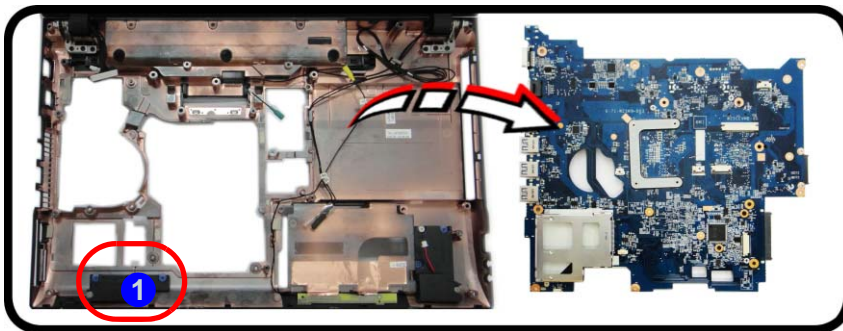

b.

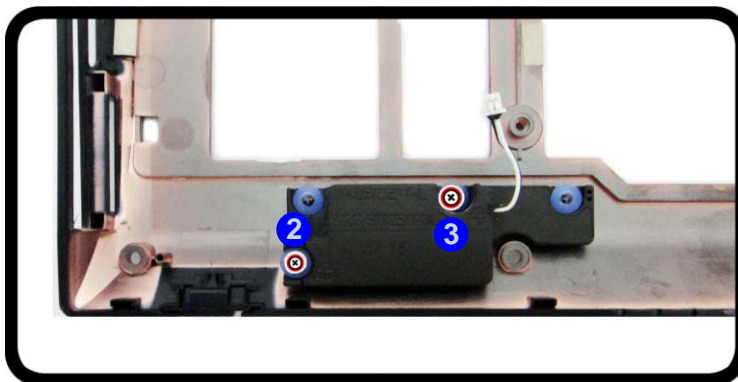

c.

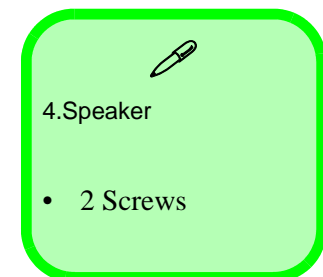
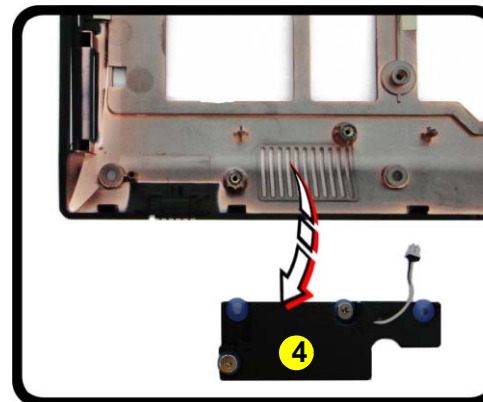

Appendix A:Part Lists

This appendix breaks down the *W25CSW* series notebook's construction into a series of illustrations. The component part numbers are indicated in the tables opposite the drawings.

Note: This section indicates the *manufacturer's* part numbers. Your organization may use a different system, so be sure to cross-check any relevant documentation.

Note: Some assemblies may have parts in common (especially screws). However, the part lists DO NOT indicate the total number of duplicated parts used.

Note: Be sure to check any update notices. The parts shown in these illustrations are appropriate for the system at the time of publication. Over the product life, some parts may be improved or re-configured, resulting in *new* part numbers.

Part List Illustration Location

The following table indicates where to find the appropriate part list illustration.

Table A - 1
**Part List Illustration
Location**

Part	
Top	<i>page A - 3</i>
Bottom	<i>page A - 4</i>
HDD	<i>page A - 5</i>
DVD	<i>page A - 6</i>
LCD	<i>page A - 7</i>

Top

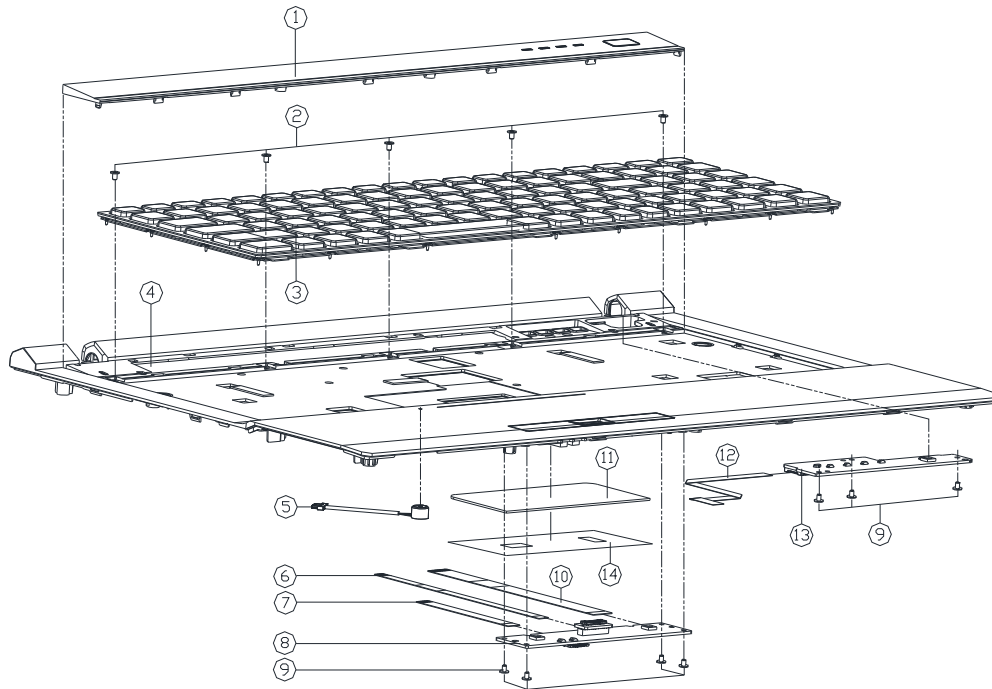
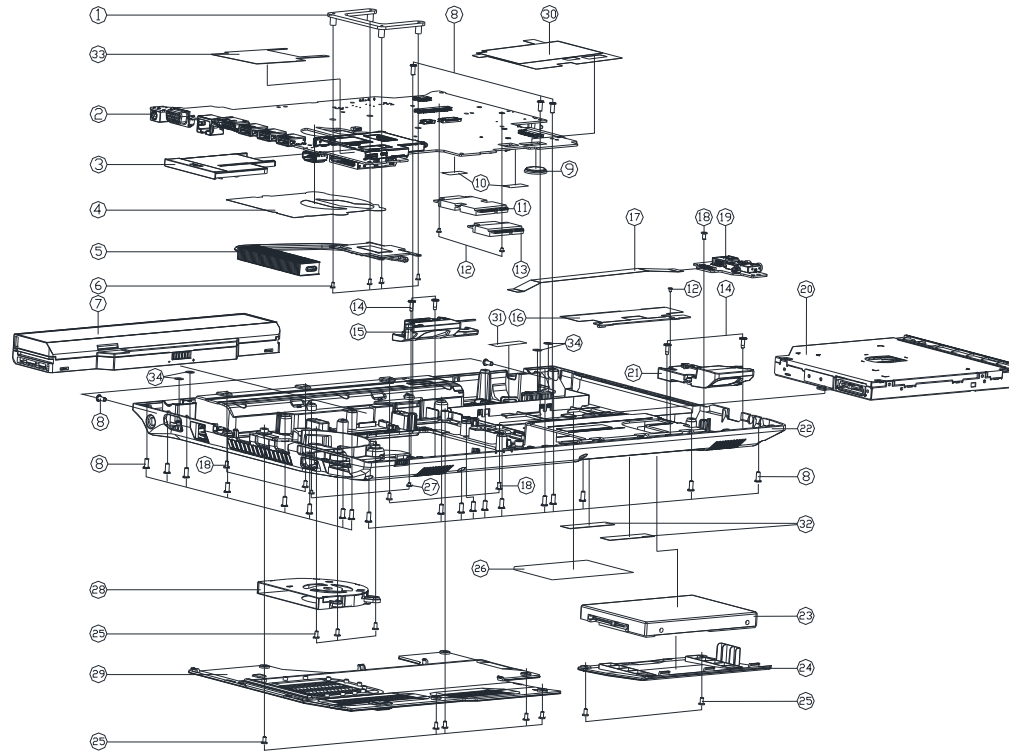

Figure A - 1
Top

ITEM	PART NAME	PART NO	REMARK
1	KB COVER MODULE W25CEW	6-42-W25W2-102	
2	SCREW M2x2.5L K1 BK/Z ICT NY 1# #35 T=05	6-35-B6120-2RD	
3	W/B K/B US/BR/AC/IN FRAME/US MIDDLE W25CSW/W25CSV	6-79-W25CSW0K-010-W	
4	TOP CASE MODULE W25CEW	6-39-W25W2-012	
5	D-MIC 6.0MM W/CABLE/BLACK L=40MM NEM300042 W25CSW	6-23-EW2W5-010	
6	FFC CABLE FOR W/B TO CLICK BOARD 4PIN V25BUD (YD)	6-43-E5100-010-3	
7	FFC CABLE FOR TOUCH PAD 6PIN 60V 6PIN (GENSHANG)	6-43-C4502-010-2	
8	CLICK BOARD V20/FINGER PRINT BOARD V4.0A W25CSW	6-77-W2W5A-N02	
9	SCREW M2x3L K1 NI ICT NY (COO=H45,DT=04)	6-35-B1120-3RE	
10	FFC CABLE FOR CLICK BOARD TO MB (HPIN PISHAW QHS)	6-43-X5100-062-2	
11	TOUCH PAD SYNAPTICS TM-80146-003 MULTI-GESTURE C4800	6-49-C4802-010	
12	FFC POWER BD TO MB (PITCH=0.5,2P/PIN)HDS W25CEW	6-43-W25W0-010	
13	POWER SW BOARD V2.0 W25CSW	6-77-W2W5S-D02	
14	TAPE MYLAR (C) (86*3880) W244HUD	6-40-W2442-040	

Bottom

Figure A - 2
Bottom



ITEM	PART	NAME	PART	NO	REMARK
1	CPU SUPPORTER	SECC T=1.5 W345U	6-33-W345S-010		
2	MAIN BOARD	V2.0 CW/3DG W25CSV	6-77-W25CSV0-000	FDR	W25CSV
2	MAIN BOARD	V2.0 CW/3DG W25CSV	6-77-W25CSV0-000-1	FDR	W25CSV
2	MAIN BOARD	V2.0 CW/3DG W25CSV	6-77-W25CSV0-000-1	FDR	W25CSV
2	MAIN BOARD	V2.0 CW/3DG W25CSV	6-77-W25CSV0-000	FDR	W25CSV
3	BATTERY	NEW CARD PC+ABS TNE20R(0.8U)	6-42-T12R3-011-2		
4	MYLAR FOR HD FAN AREA	PET W25CEW	6-40-W25WS-010		
5	ON THERM. MODULE	W/D FOR W25CEW	6-31-W25WS-102		
6	SCREW	M2*5L KI NI ICT NY	6-35-B1120-5R0		(OPTION)
7	TAPE	NYLON (C)MYLAR M550J	6-40-M55J2-030		
8	SCREW	M2.5*6L K BZ ICT NY	6-35-B6125-6RA		
9	BATTERY	3V 220MA BRBR2032B (KTS)	6-23-6A2B2-030		
10	TAPE	NYLON TRANSPARENT (GSM)HARD P180M	6-40-P1803-020		
11	SCREW	M2*5L KI NI ICT NY (D0=44.5D1=64)	6-88-W650W-8800		(OPTION)
12	SCREW	M2*5L KI NI ICT NY (D0=44.5D1=64)	6-35-B1120-3RE		
13	SCREW	M2*5L KI NI ICT NY (D0=44.5D1=64)	6-88-W230F-4200		
14	SCREW	M2*6.2L NI ICT NY FOR SPEAKER	6-35-Z1120-6R2		
15	SCREW	L 2*4H NY P 2*MM SPEAKER (NY W25C)	6-23-5W25W-0L1		
16	SCREW	L 2*4H NY P 2*MM SPEAKER (NY W25C)	6-23-7W25W-031		
17	ITC CABLE	NY TO AUDIO BOARD 22PH HD W25C	6-43-W25CS-022		
18	AUDIO BOARD	V2.0 W25CSV	6-77-W25WB-002		
19	AUDIO BOARD	V2.0 W25CSV	6-77-W25WB-002		
20	W/D HDD ASS'Y	W25CEW	6-79-W25CW0-000		
20	SATA DVD SUPER MULTI ASSY	(OPTION)	6-79-W25CW0-000		
21	SCREW	L 2*4H NY P 2*MM SPEAKER (NY W25C)	6-23-5W25W-0R0		
22	BOTTOM CASE MODULE	W25CEW	6-39-W25W3-011		
23	W/D HDD ASS'Y	W25CEW	6-79-W25CW0-000		
23	W/HDD ASS'Y	W25CEW	6-79-W25CW0-000		
24	HDD COVER	PC+ABS W25CEW	6-42-W25WJ-011		
25	SCREW	M2.5*5L KI BK/2 ICT NY	6-35-B6125-5RA		
26	PRODUCT LABEL	FDR W25CSV	6-45-W25CS03-010		
26	PRODUCT LABEL	FDR W25CSV	6-45-W25CS03-010		
27	SCREW	M2*5L KI NI ICT NY (D0=44.5D1=64)	6-35-C2120-3R0		
28	FAN MODULE	W251HUG	6-31-W25WS-100		
29	CPU COVER MODULE	W25CEW	6-42-W25WB-101		
30	MYLAR	(C)MYLAR M550J	6-40-M55J2-030		
31	TAPE	NYLON (C)MYLAR M550J	6-40-M55J2-030		
32	HDD 7MM SPONGE	(40*40*25) CR4030 P1073N	6-47-0019A-405		For 7mm HDD
33	MYLAR	(C)MYLAR M550J	6-40-W1302-010		
34	MYLAR	(C)MYLAR M550J	6-37-02000-603		

HDD

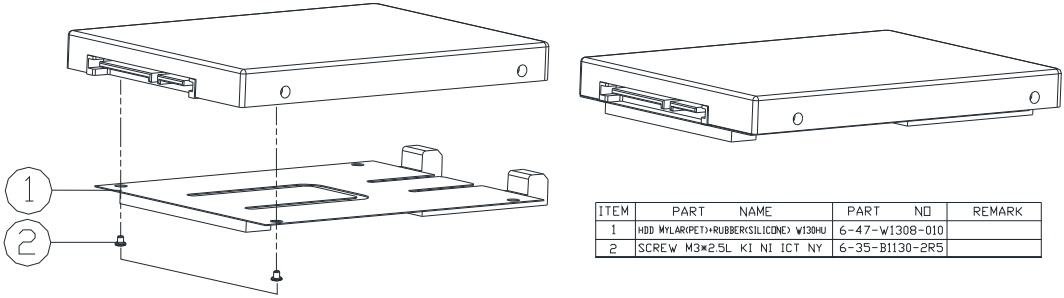

ITEM	PART NAME	PART NO	REMARK
1	HDD W/LAR(PET)+RUBBER(SILICONE) W/30HJ	6-47-W1308-010	
2	SCREW M3*2.5L K1 NI ICT NY	6-35-B1130-2R5	

Figure A - 3
HDD

DVD

Figure A - 4
DVD

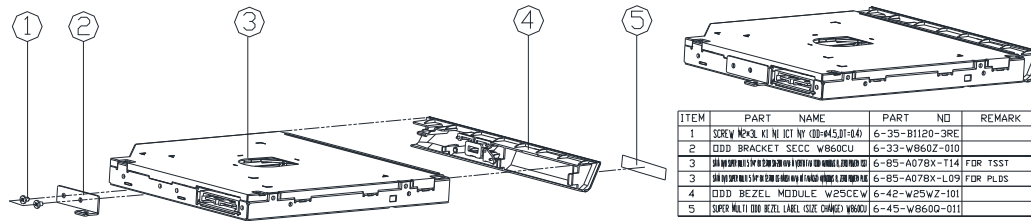

ITEM	PART NAME	PART NO	REMARK
1	SCREW HEX X 4.5 (0.145,0.184)	6-35-B1120-3RE	
2	ODD BRACKET SECC W8600U	6-33-W860Z-010	
3	ODD BEZEL MODULE W25CEW FOR PLDS	6-85-A078X-114	FOR TSST
4	ODD BEZEL MODULE W25CEW	6-85-A078X-L09	FOR PLDS
5	ODD BEZEL LABEL (SIZE CHANGE) W8600	6-45-W8600-011	



Appendix B: Schematic Diagrams

This appendix has circuit diagrams of the W25CSW notebook's PCB's. The following table indicates where to find the appropriate schematic diagram.

Diagram - Page	Diagram - Page	Diagram - Page
<i>System Block Diagram - Page B - 2</i>	<i>Lynx 4/9 - Page B - 19</i>	<i>5VS, 3VS, 3.3VM, 5VM - Page B - 36</i>
<i>Processor 1/7 - Page B - 3</i>	<i>Lynx 5/9 - Page B - 20</i>	<i>1.05V Series - Page B - 37</i>
<i>Processor 2/7 - Page B - 4</i>	<i>Lynx 6/9 - Page B - 21</i>	<i>VDD3, VDD5 - Page B - 38</i>
<i>Processor 3/7 - Page B - 5</i>	<i>Lynx 7/9 - Page B - 22</i>	<i>Power 1.5V, 1.35V, 0.75VS, 1.5VS - Page B - 39</i>
<i>Processor 4/7 - Page B - 6</i>	<i>Lynx 8/9 - Page B - 23</i>	<i>POWER V_CORE 1 - Page B - 40</i>
<i>Processor 5/7 - Page B - 7</i>	<i>Lynx 9/9 - Page B - 24</i>	<i>AC IN, Charger - Page B - 41</i>
<i>Processor 6/7 - Page B - 8</i>	<i>Intel LAN i217LM - Page B - 25</i>	<i>Audio Board - Page B - 42</i>
<i>Processor 7/7 - Page B - 9</i>	<i>LAN Transformer - Page B - 26</i>	<i>Power Switch & LID Board - Page B - 43</i>
<i>DDR3 SO-DIMM_0 - Page B - 10</i>	<i>Card Reader RTS5229 - Page B - 27</i>	<i>CLICK BOARD - Page B - 44</i>
<i>DDR3 SO-DIMM_1 - Page B - 11</i>	<i>USB Port, E-SATA - Page B - 28</i>	<i>FINGERPRINT BOARD - Page B - 45</i>
<i>PS8625 - Page B - 12</i>	<i>3G, HDD, ODD - Page B - 29</i>	
<i>LVDS, Inverter - Page B - 13</i>	<i>WLAN, CCD, TPM - Page B - 30</i>	
<i>HDMI - Page B - 14</i>	<i>KBC-ITE IT8587 - Page B - 31</i>	
<i>CRT - Page B - 15</i>	<i>AUDIO CODEC ALC269 - Page B - 32</i>	
<i>Lynx 1/9 - Page B - 16</i>	<i>New Card, GSensor - Page B - 33</i>	
<i>Lynx 2/9 - Page B - 17</i>	<i>Fan, TP, Connector - Page B - 34</i>	
<i>Lynx 3/9 - Page B - 18</i>	<i>Docking Connector, COM Port - Page B - 35</i>	

Table B - 1
**SCHEMATIC
DIAGRAMS**



Version Note

The schematic diagrams in this chapter are based upon version 6-7P-W2W55-002. If your mainboard (or other boards) are a later version, please check with the Service Center for updated diagrams (if required).

System Block Diagram

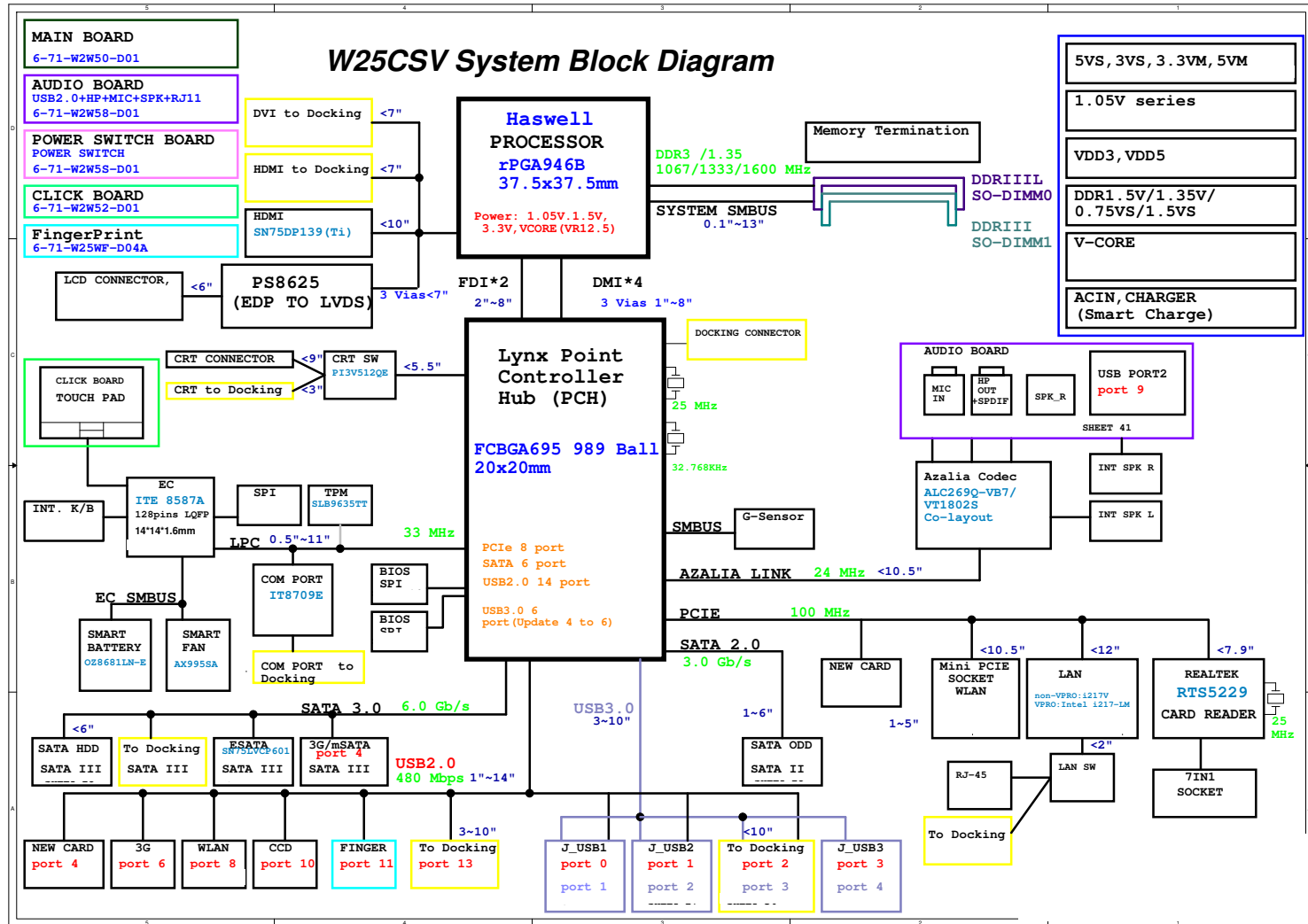

Sheet 1 of 44
System Block
Diagram

Processor 1/7

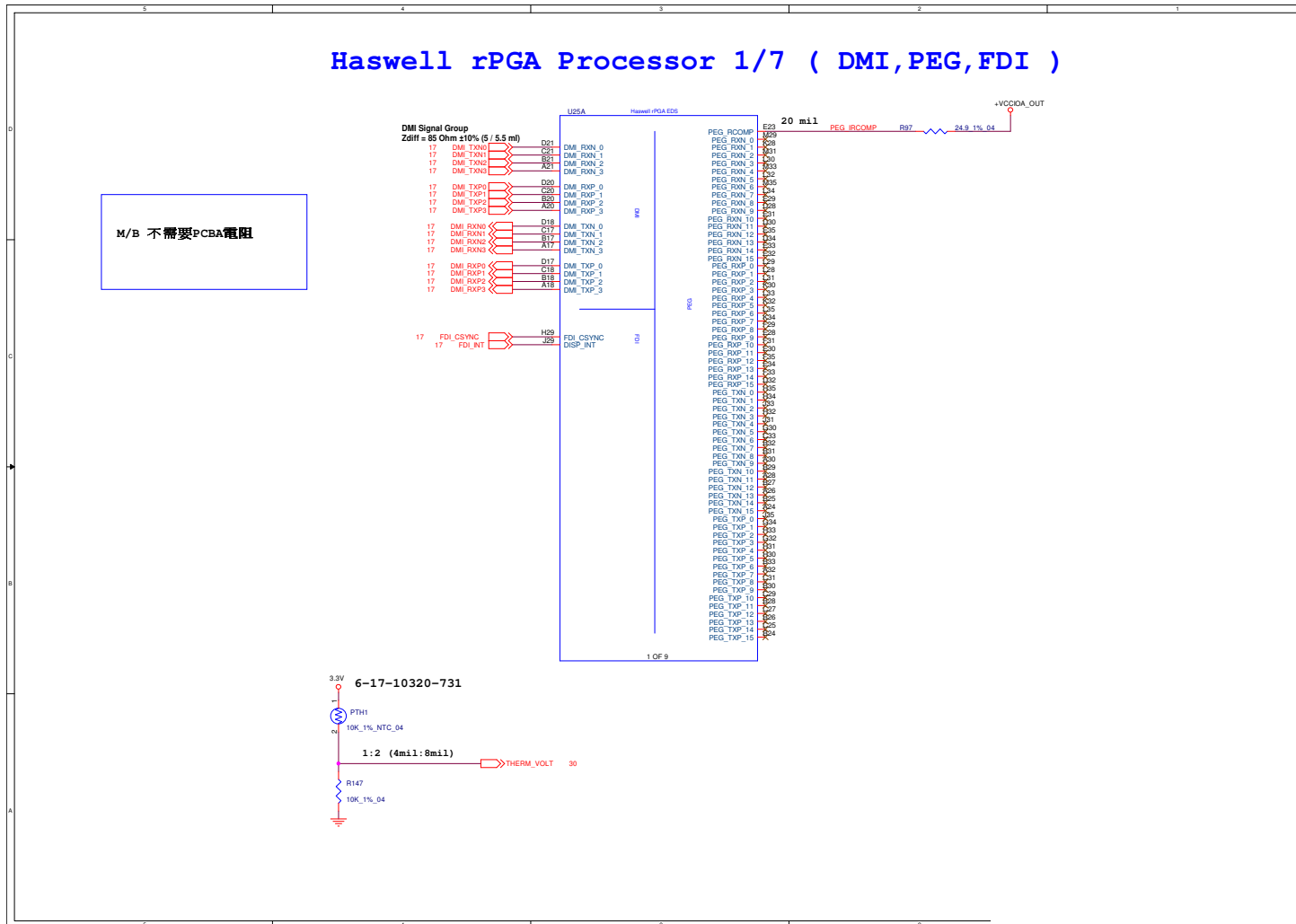

M/B 不需要PCBA電阻

Sheet 2 of 44
Processor 1/7

B.Schematic Diagrams

Processor 5/7

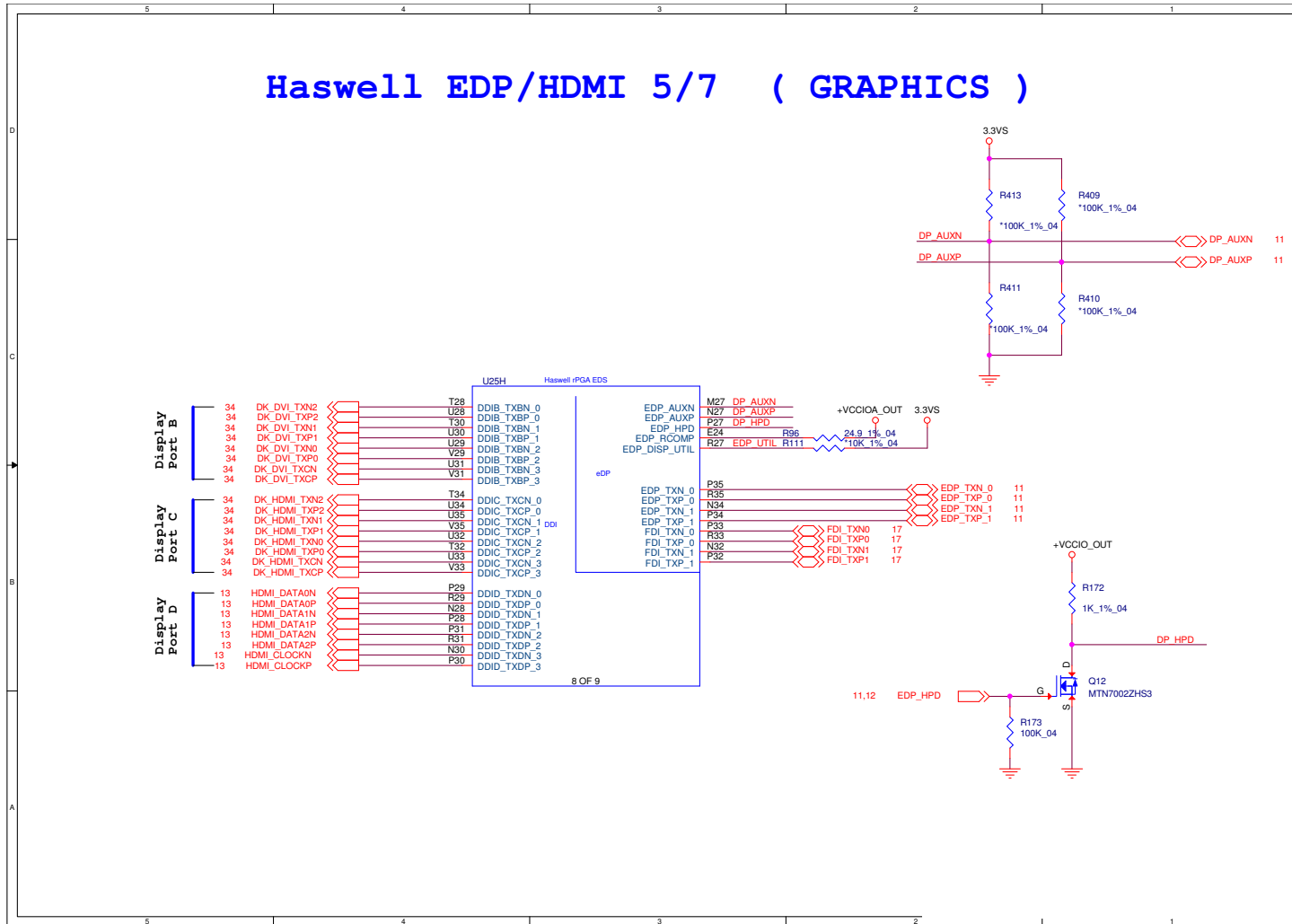

Sheet 6 of 44
Processor 5/7

B.Schematic Diagrams

Processor 7/7

Haswell Processor 7/7 (RESERVED)

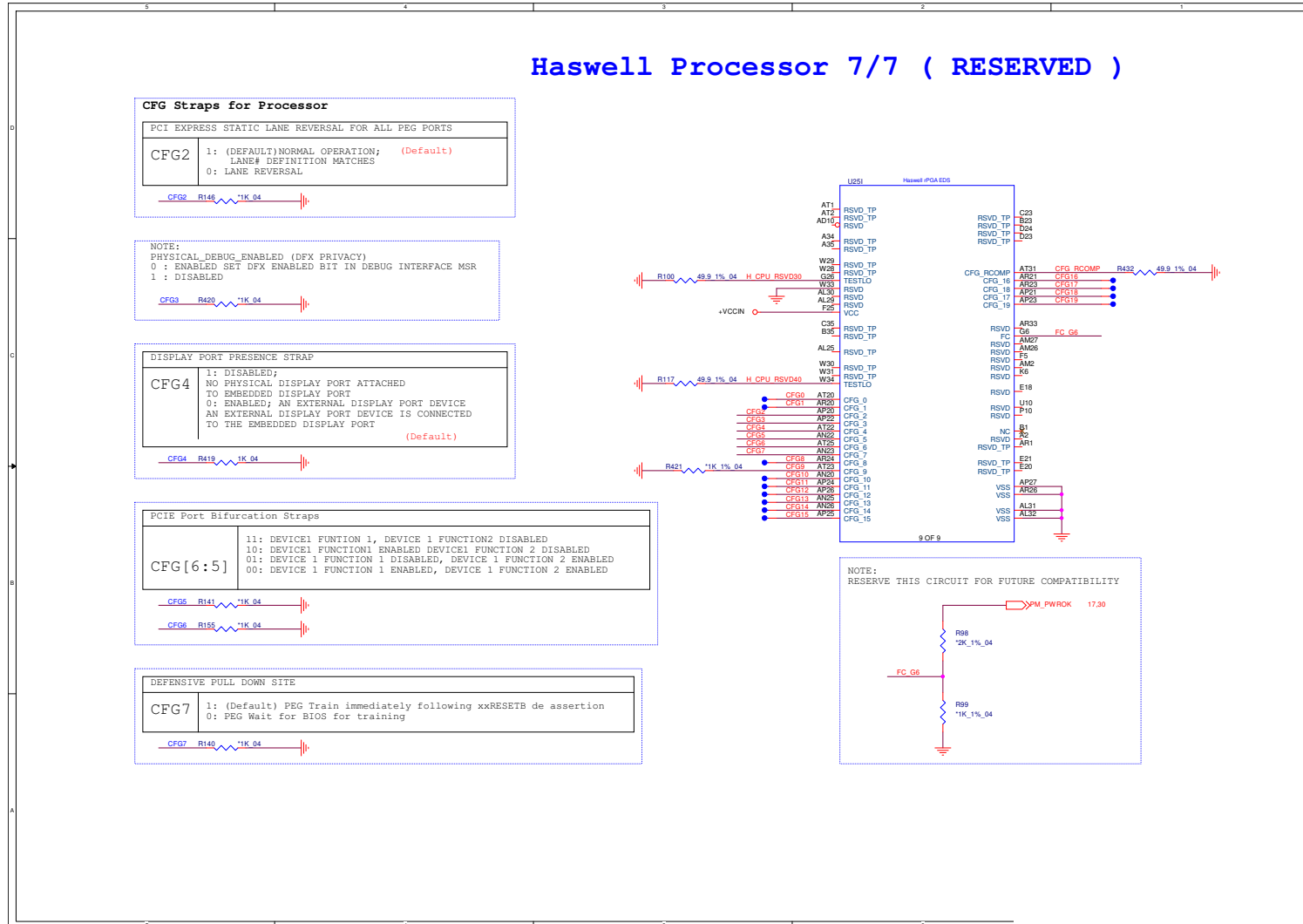

Sheet 8 of 44
Processor 7/7

DDR3 SO-DIMM_0

Sheet 9 of 44
DDR3 SO-DIMM_0

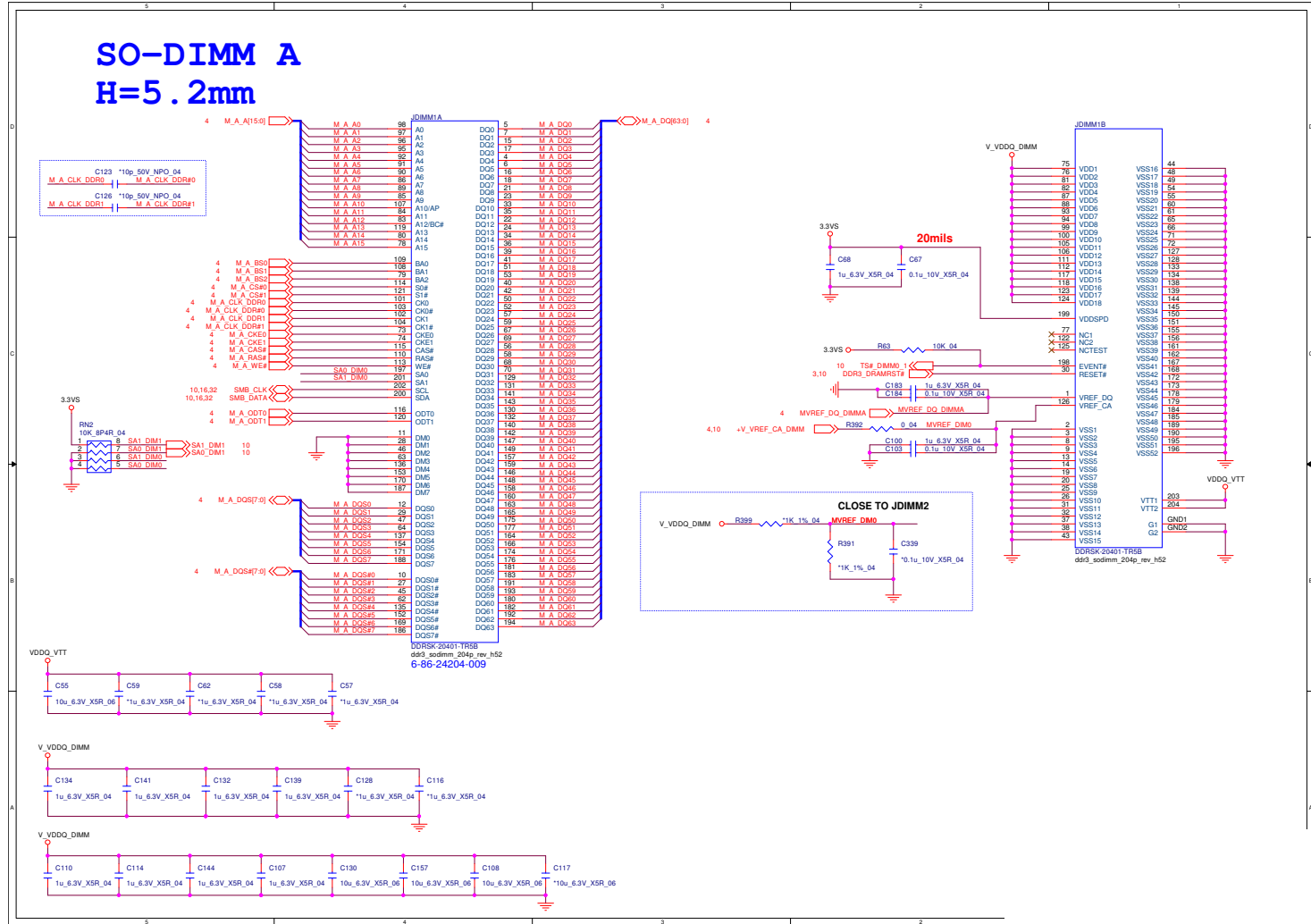

DDR3 SO-DIMM_1

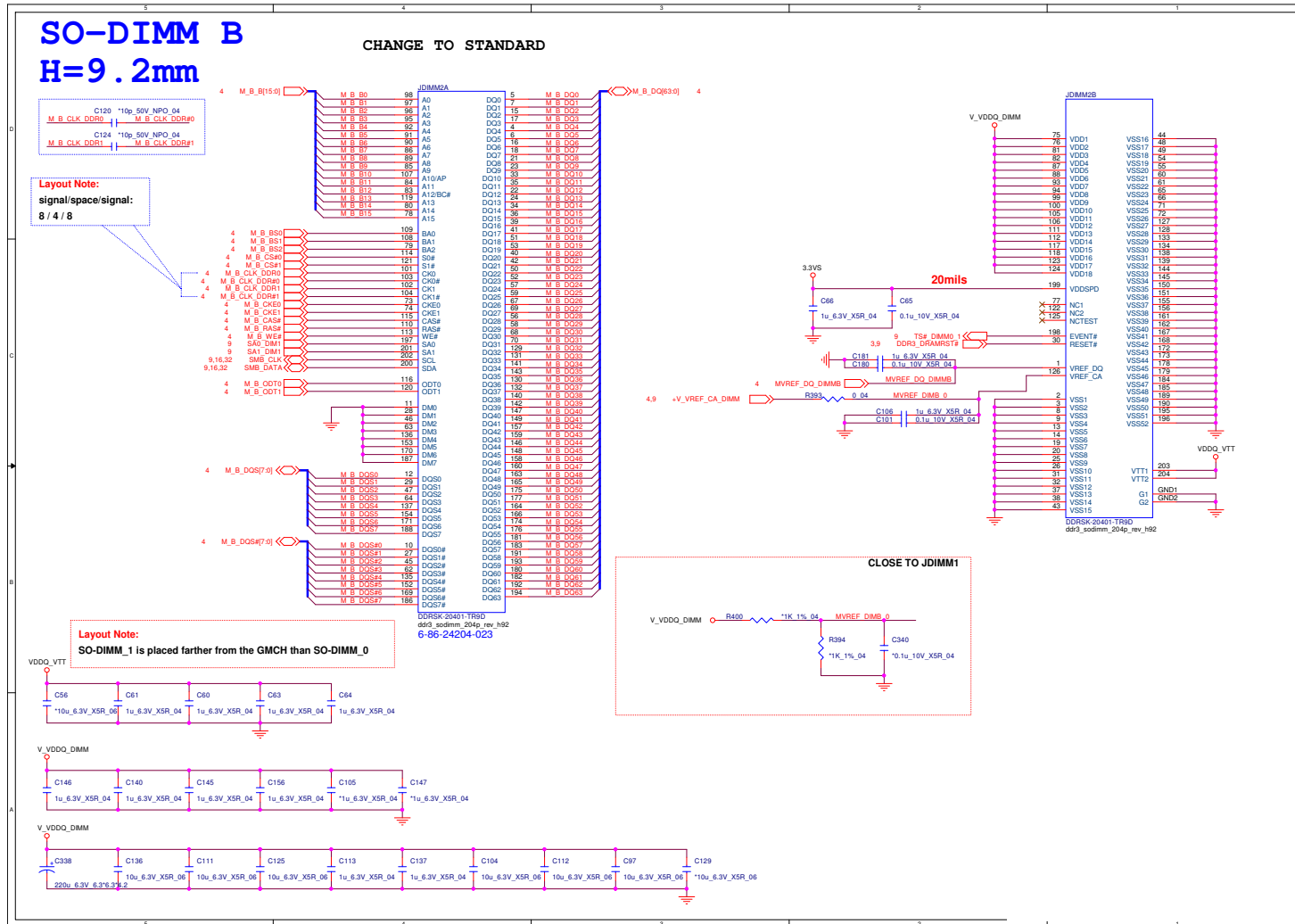

LVDS, Inverter

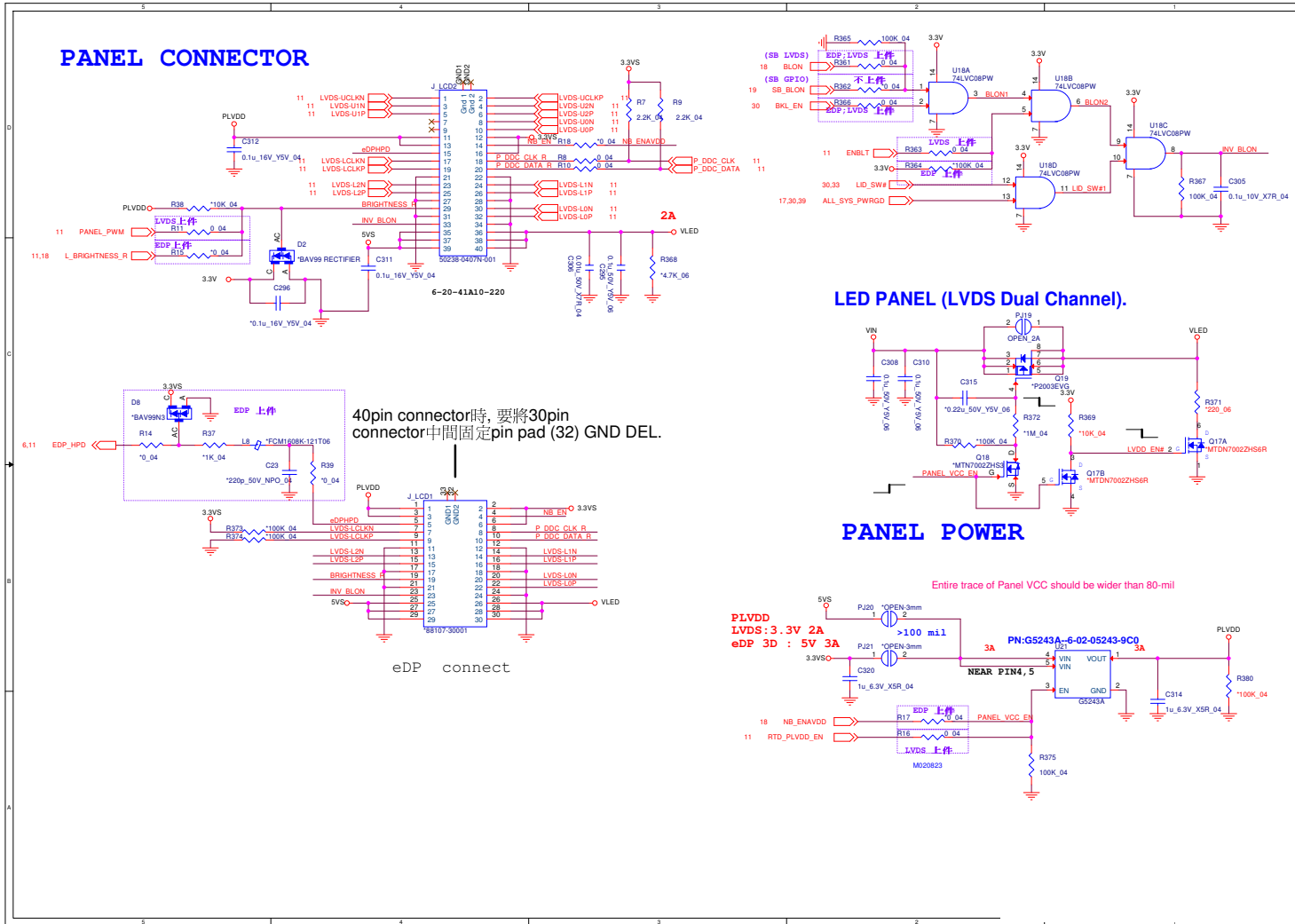

Sheet 12 of 44
LVDS, Inverter

B.Schematic Diagrams

HDMI

Sheet 13 of 44
HDMI

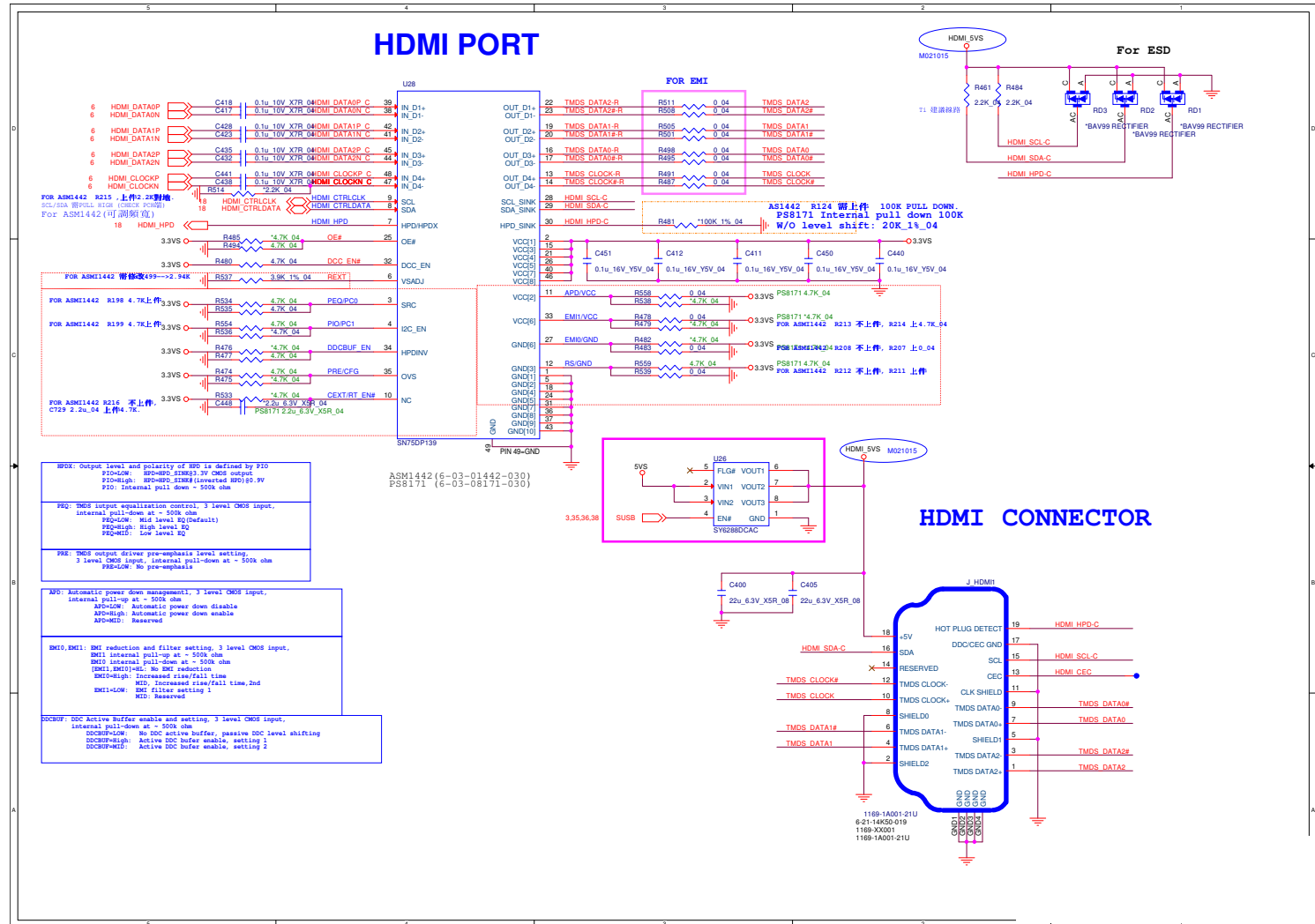

CRT

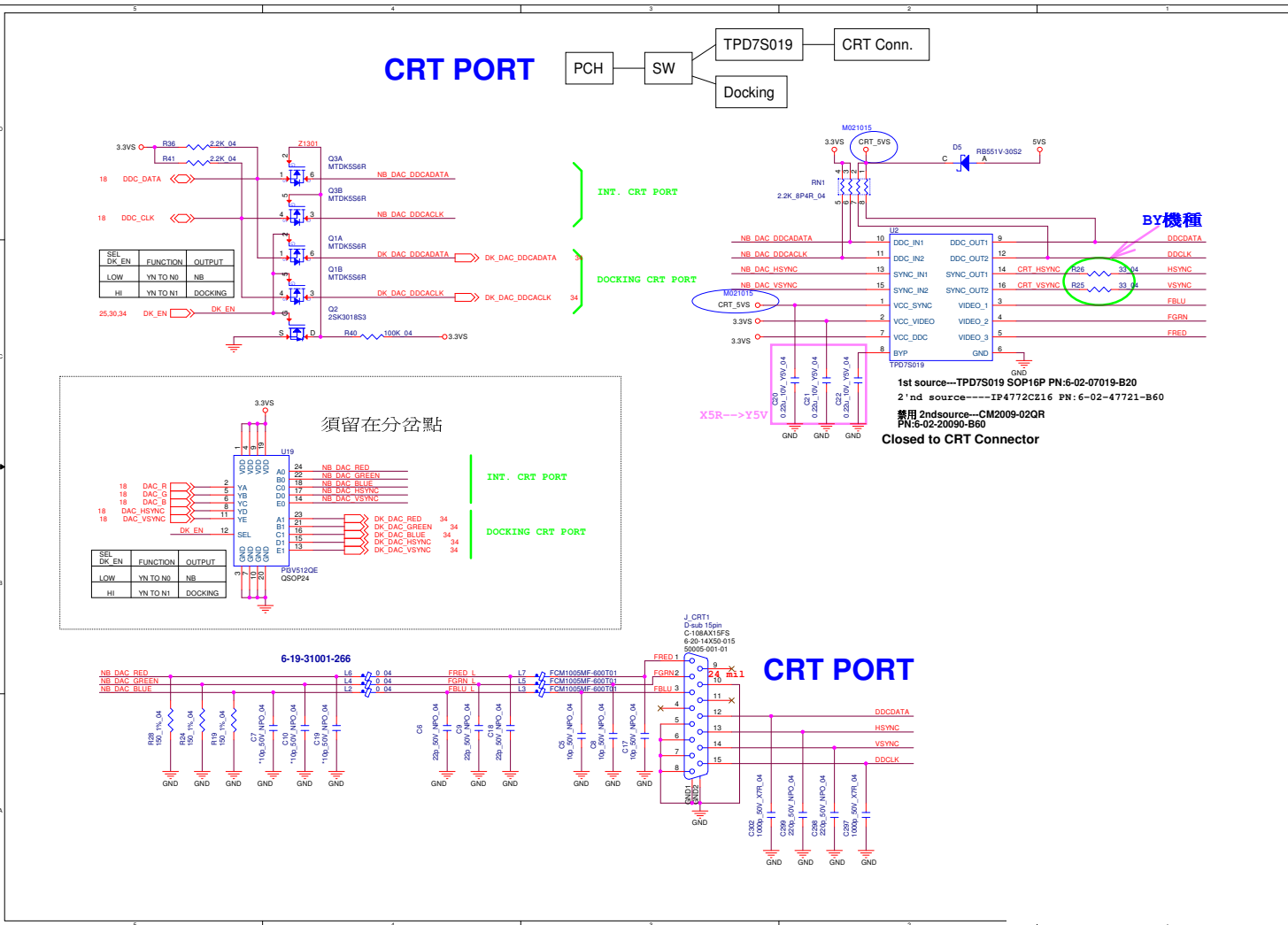

Sheet 14 of 44
 CRT

Lynx 1/9

Sheet 15 of 44
Lynx 1/9

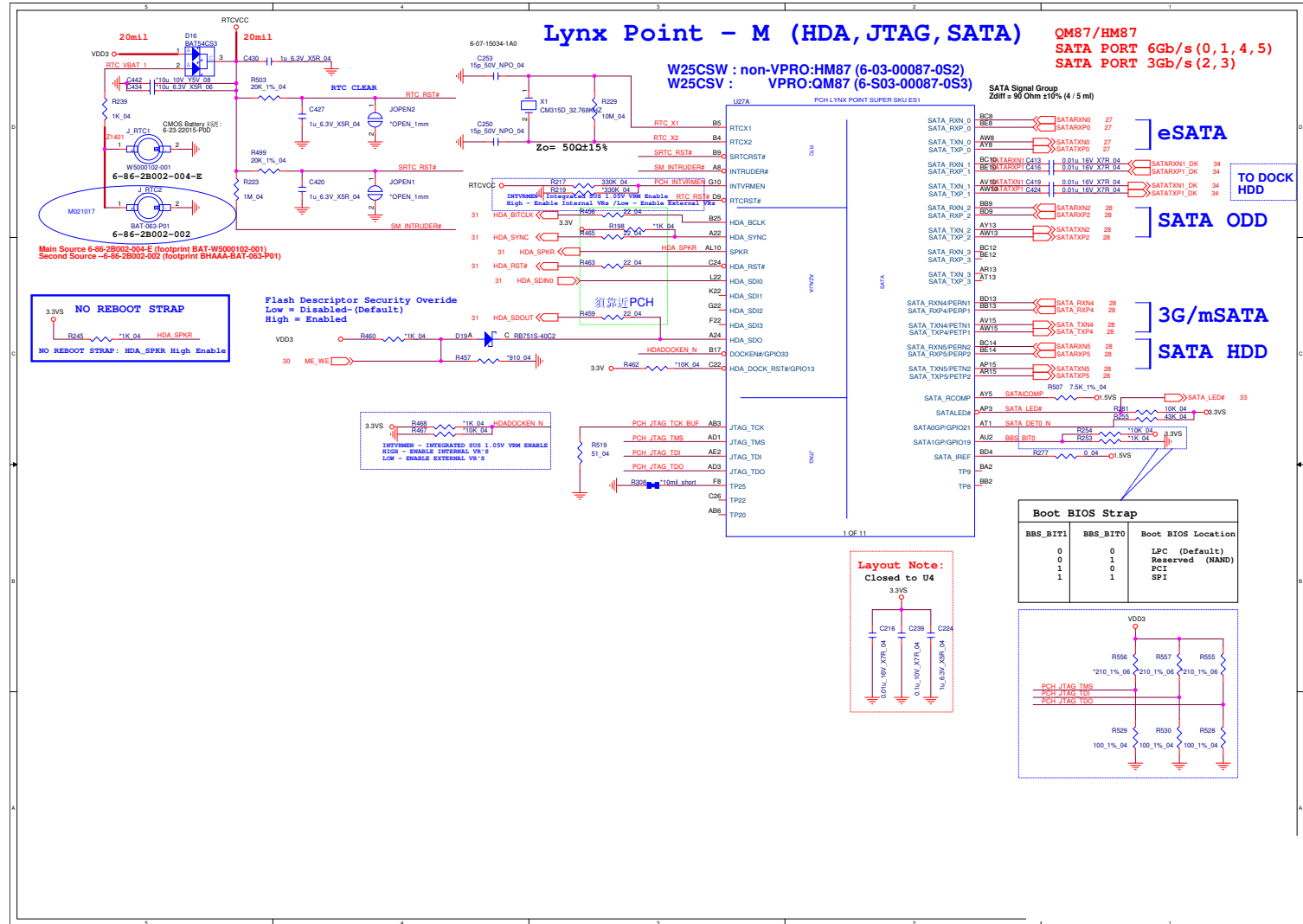

Lynx 2/9

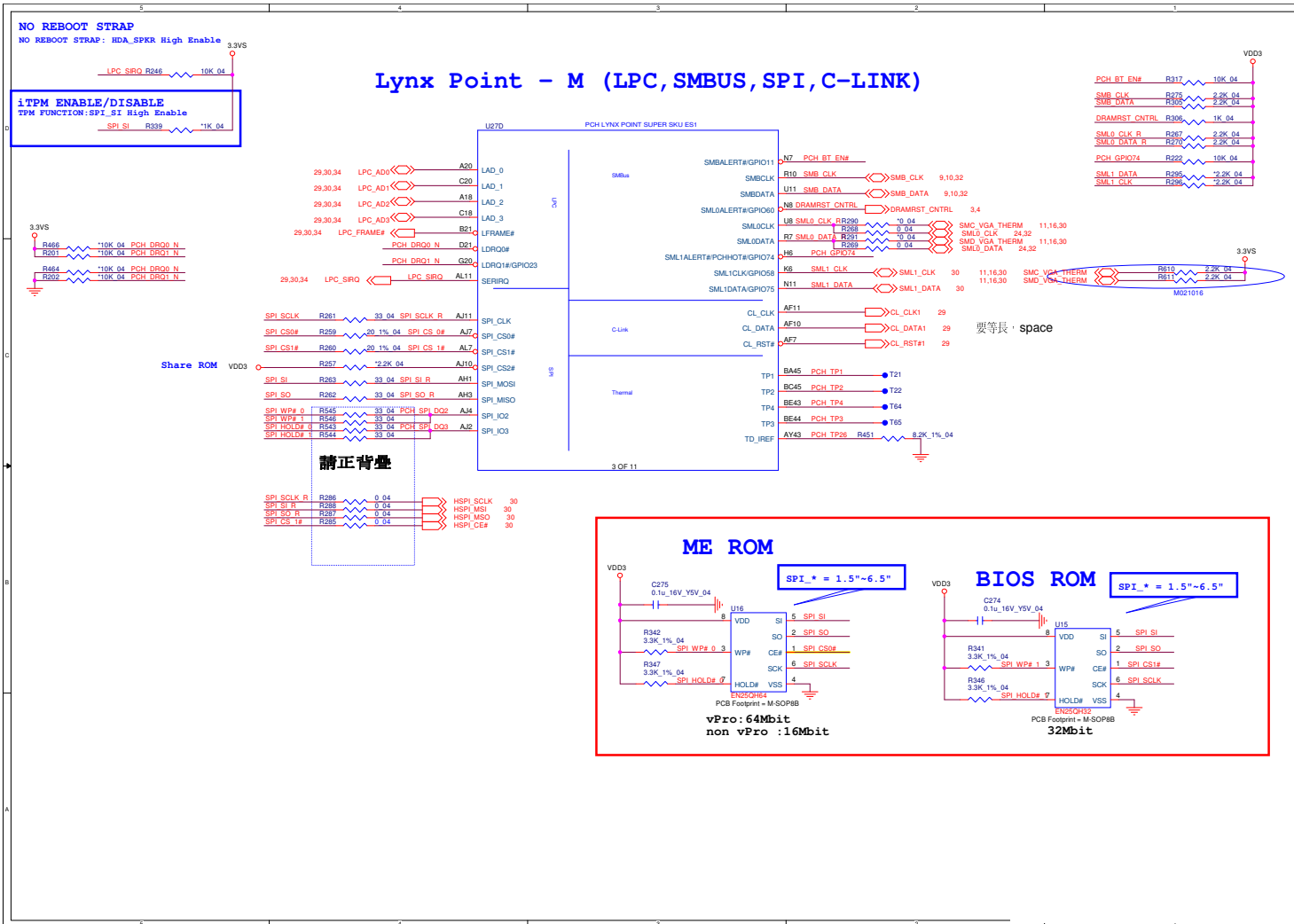

Sheet 16 of 44
Cougar Point M 2/9

B.Schematic Diagrams

Lynx 4/9

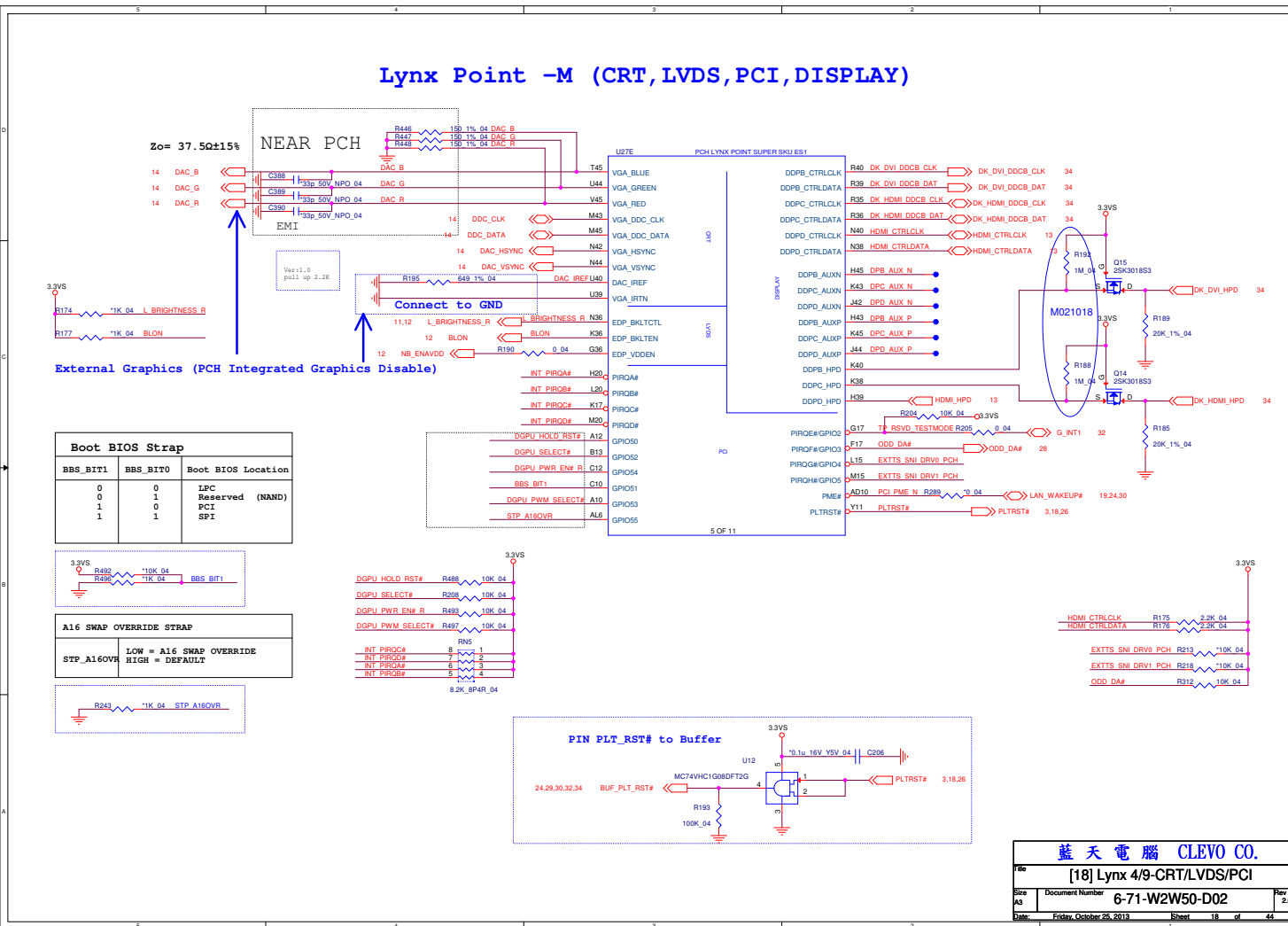

Sheet 18 of 44
Lynx 4/9

B.Schematic Diagrams

藍天電腦 CLEVO CO.

[18] Lynx 4/9-CRT/LVDS/PCI		
Doc No	Document Number	Rev
A3	6-71-W2W50-D02	2.0
Date	Friday, October 25, 2013	Sheet 18 of 44

Lynx 5/9

Sheet 19 of 44
Lynx 5/9

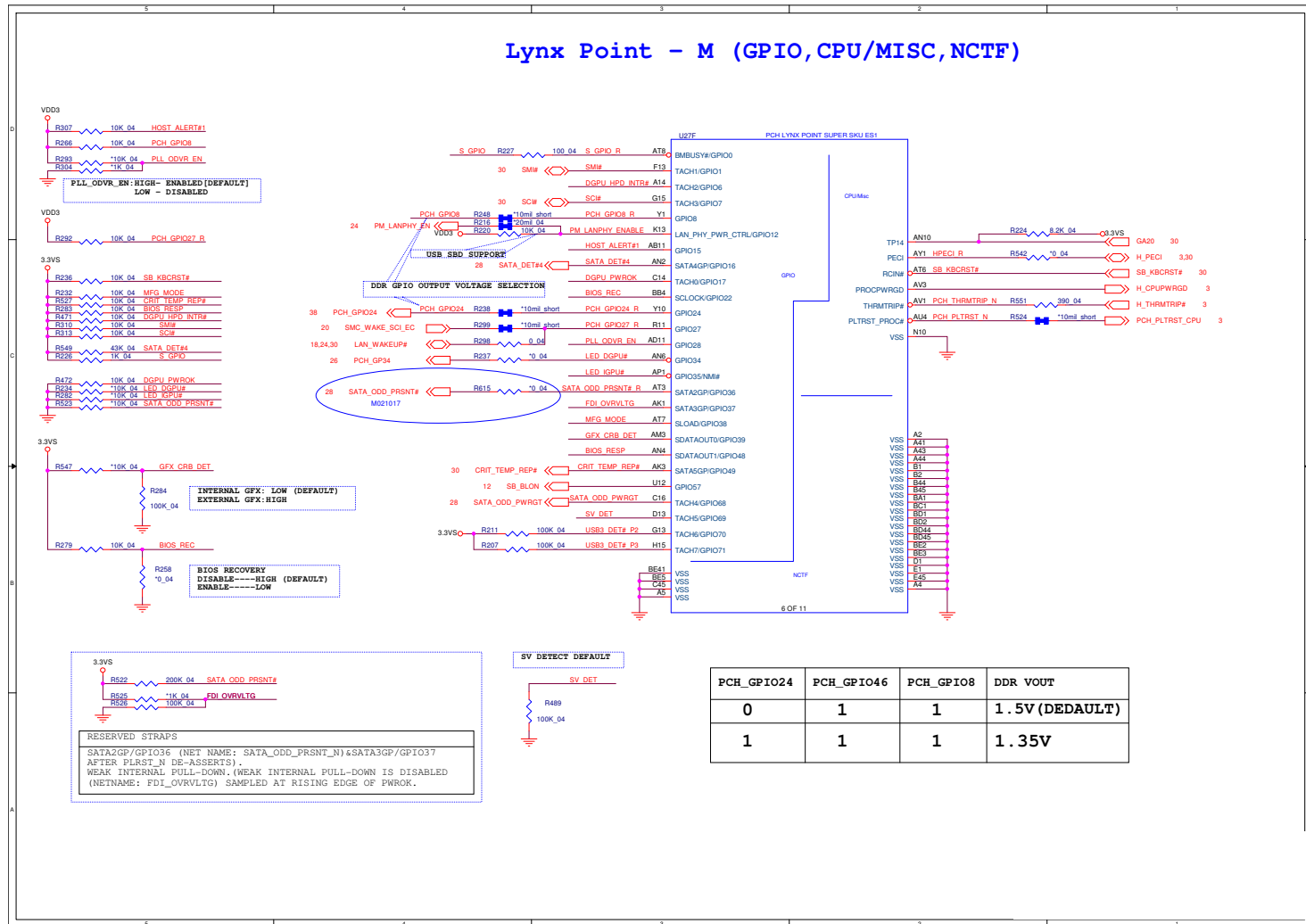

Lynx 6/9

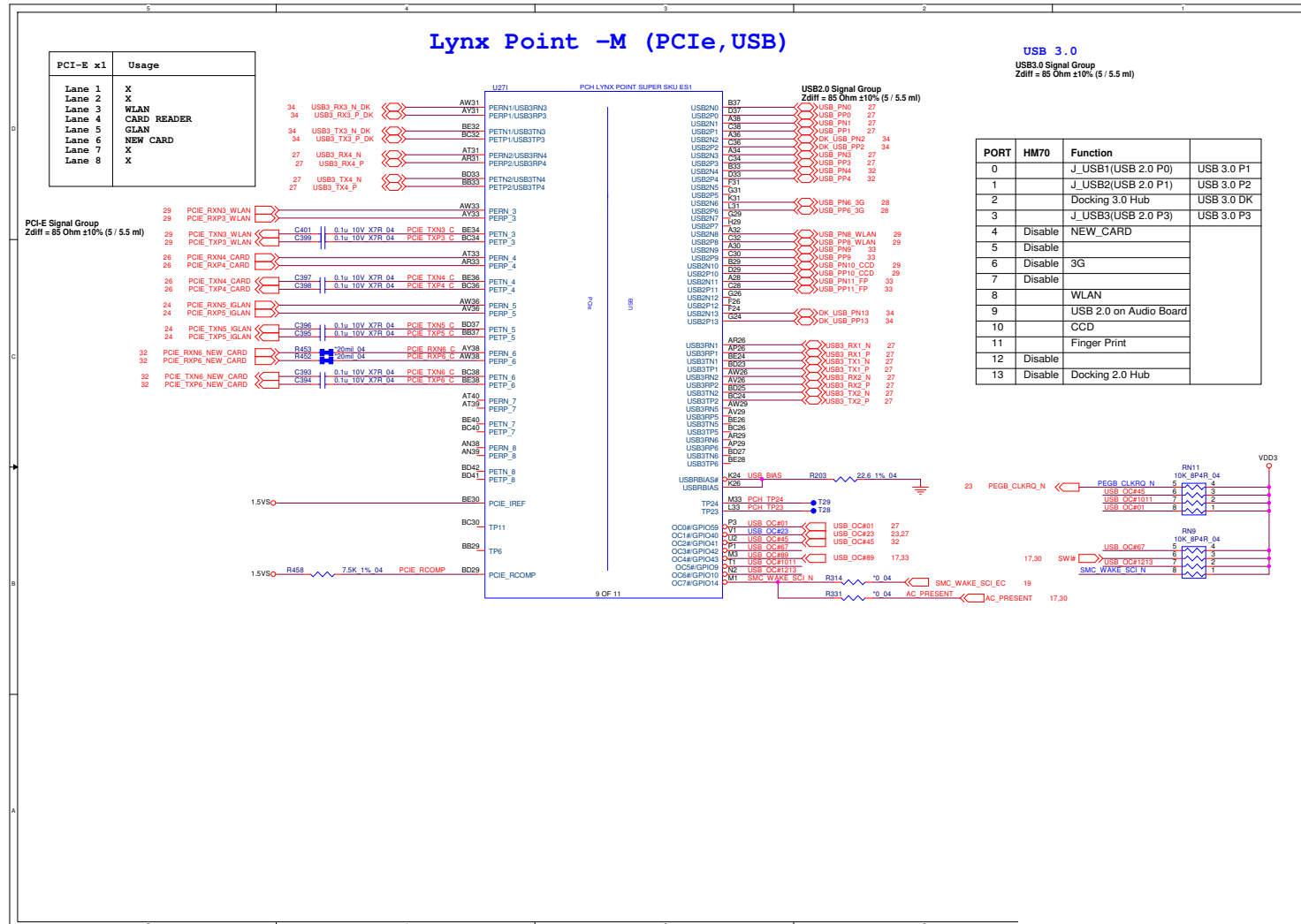

Sheet 20 of 44
Lynx 6/9

B.Schematic Diagrams

Lynx 7/9

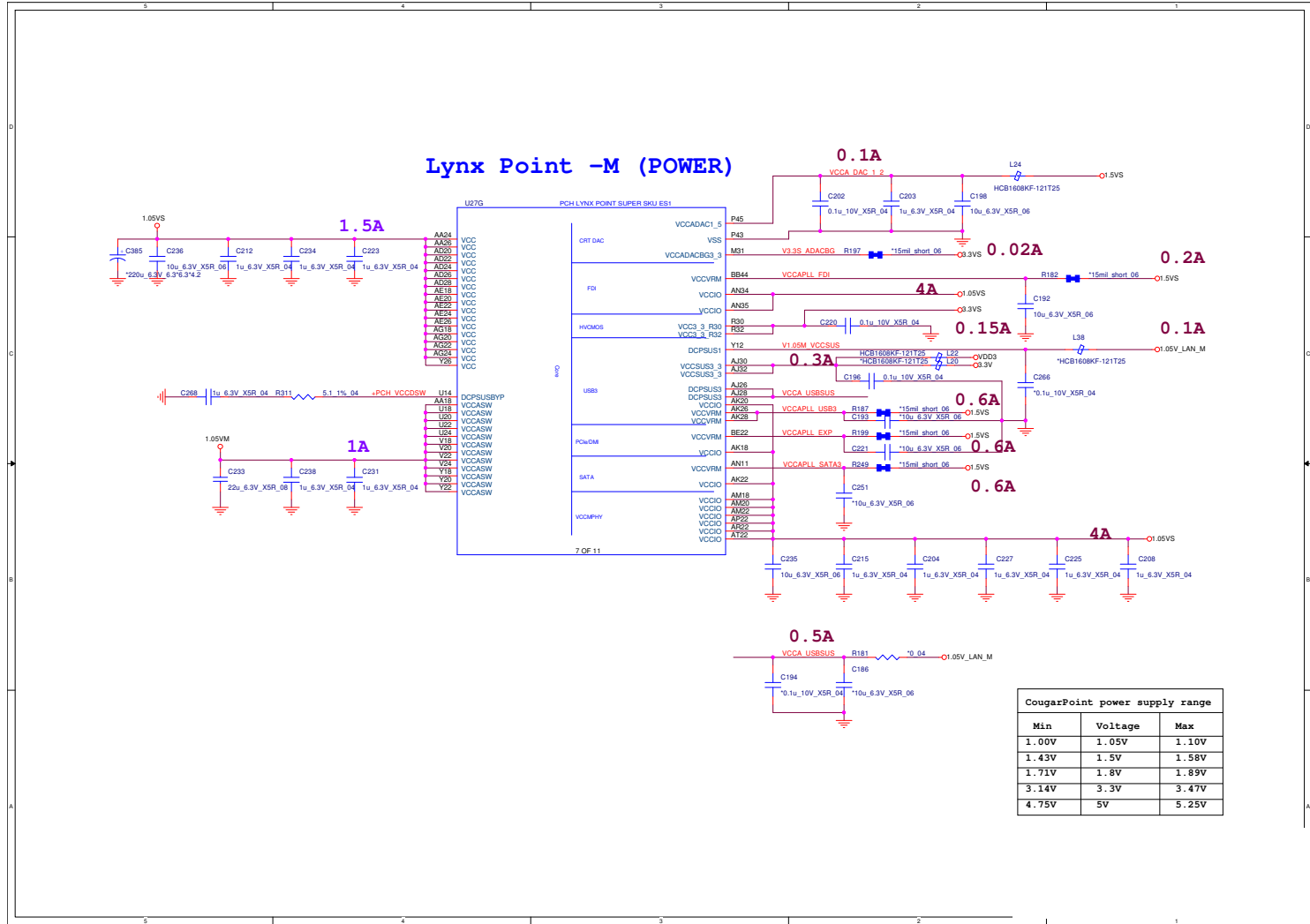

Sheet 21 of 44
Lynx 7/9

Lynx 9/9

Sheet 23 of 44
Lynx 9/9

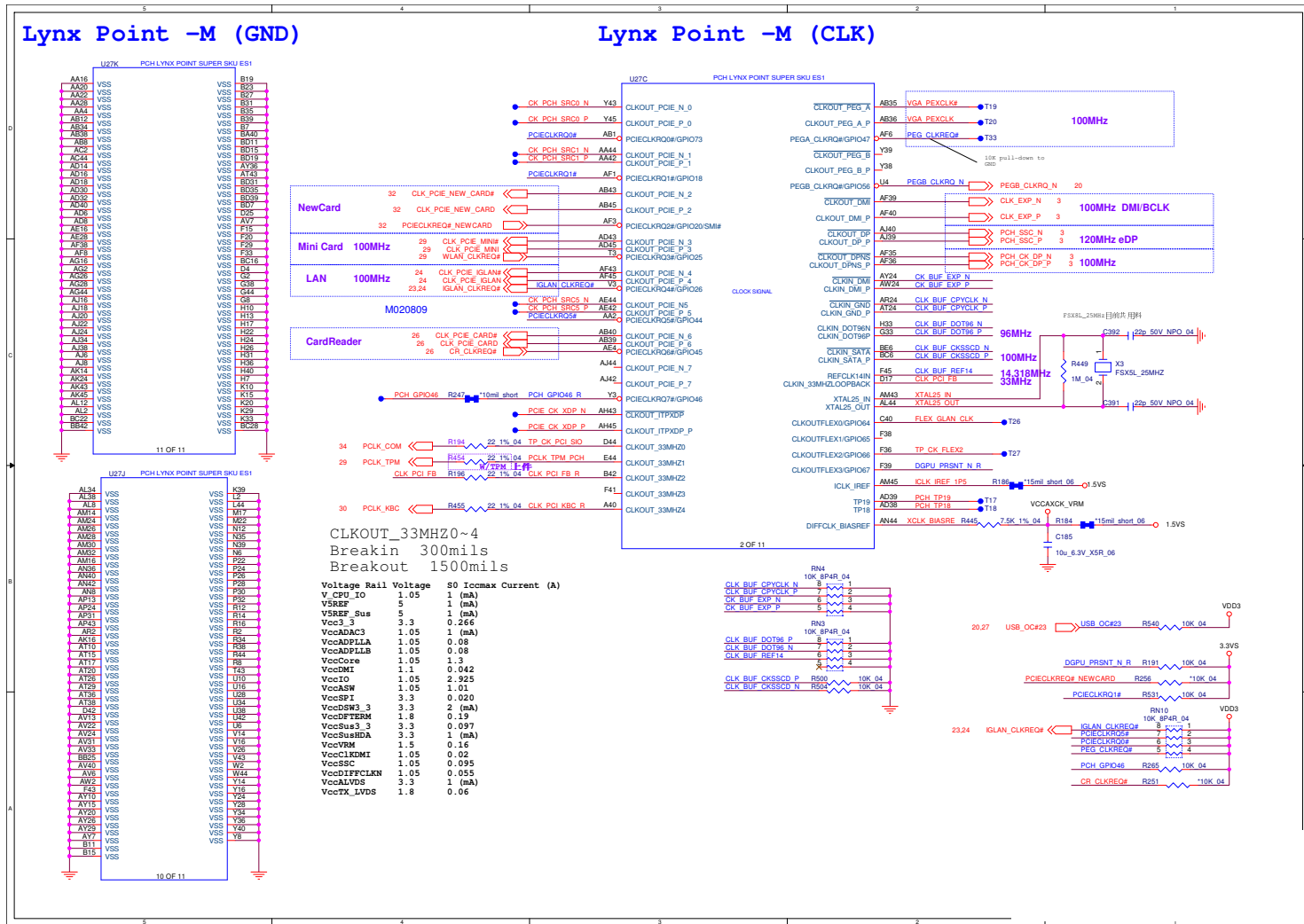

Intel LAN i217LM

Sheet 24 of 44
Intel LAN i217LM

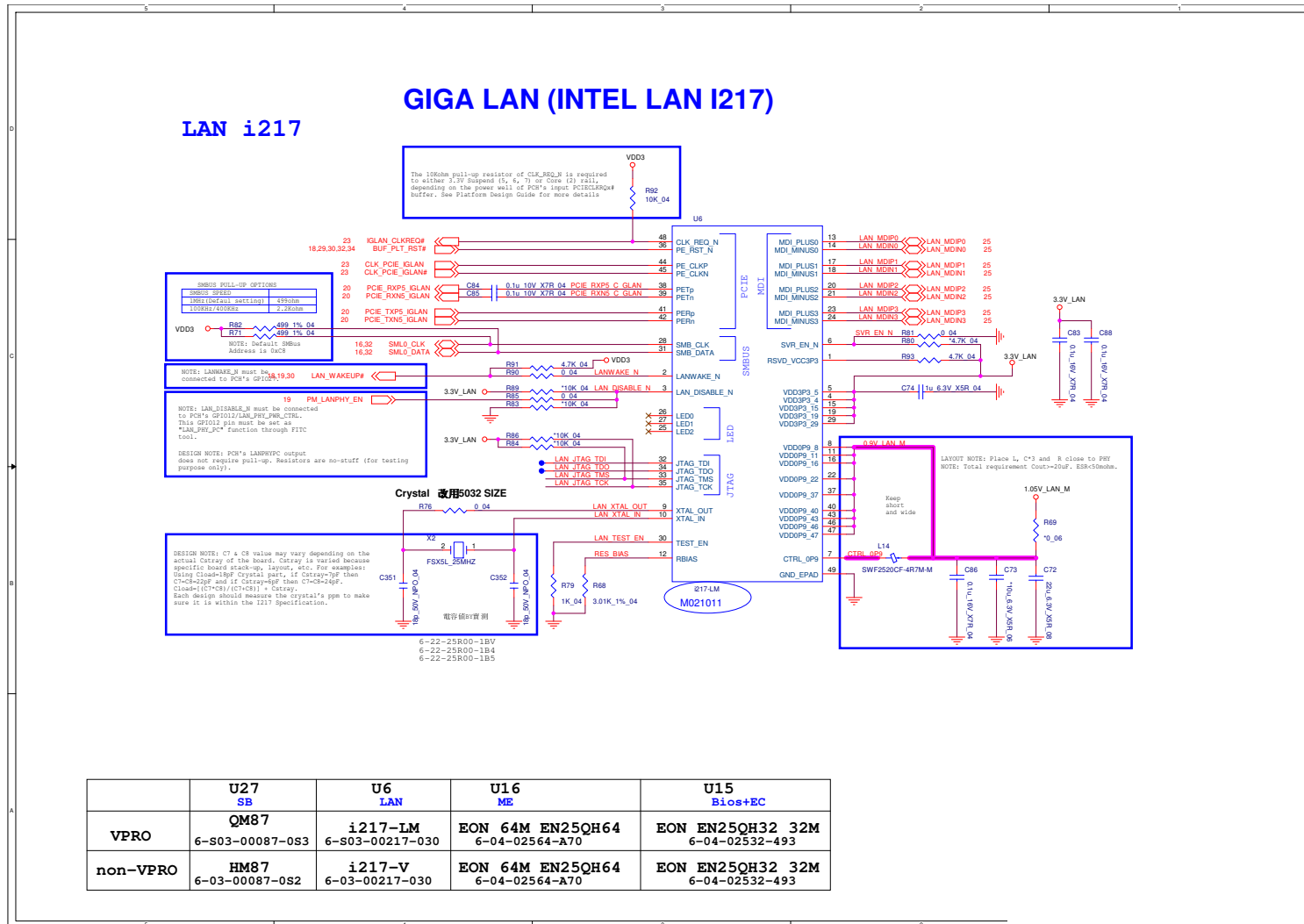

LAN Transformer

Sheet 25 of 44
LAN Transformer

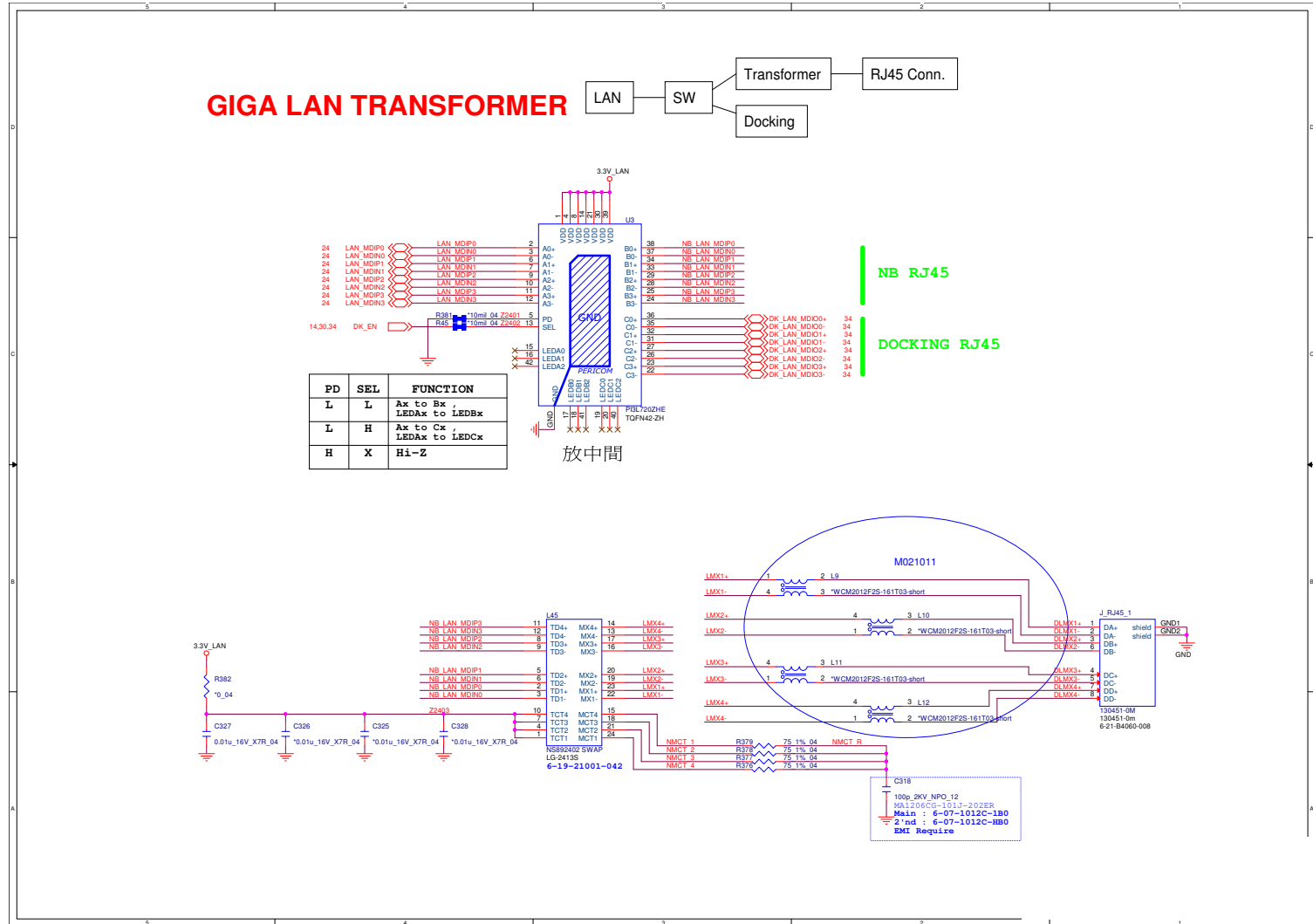

USB Port, E-SATA

Sheet 27 of 44
USB Port, E-SATA

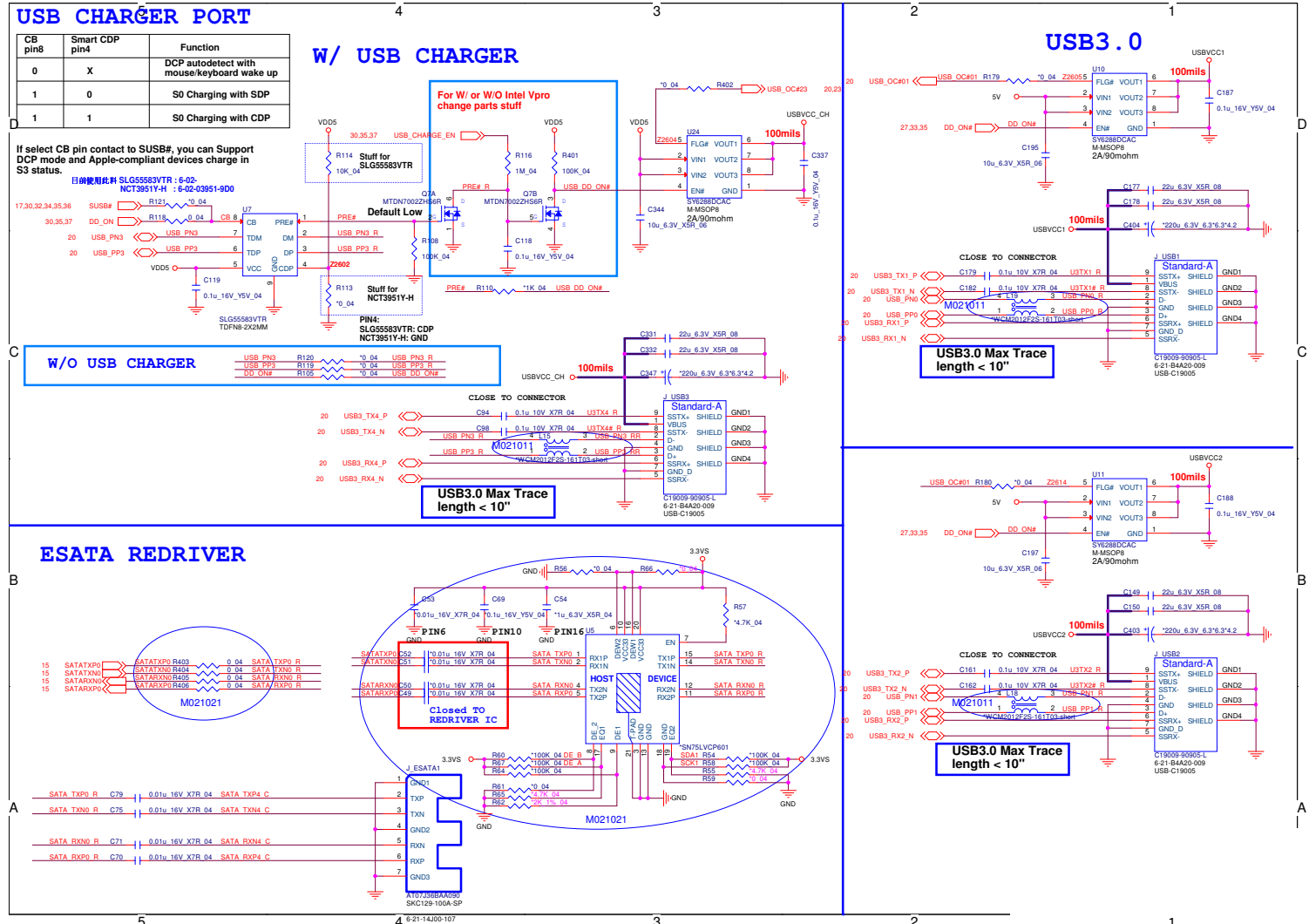

3G, HDD, ODD

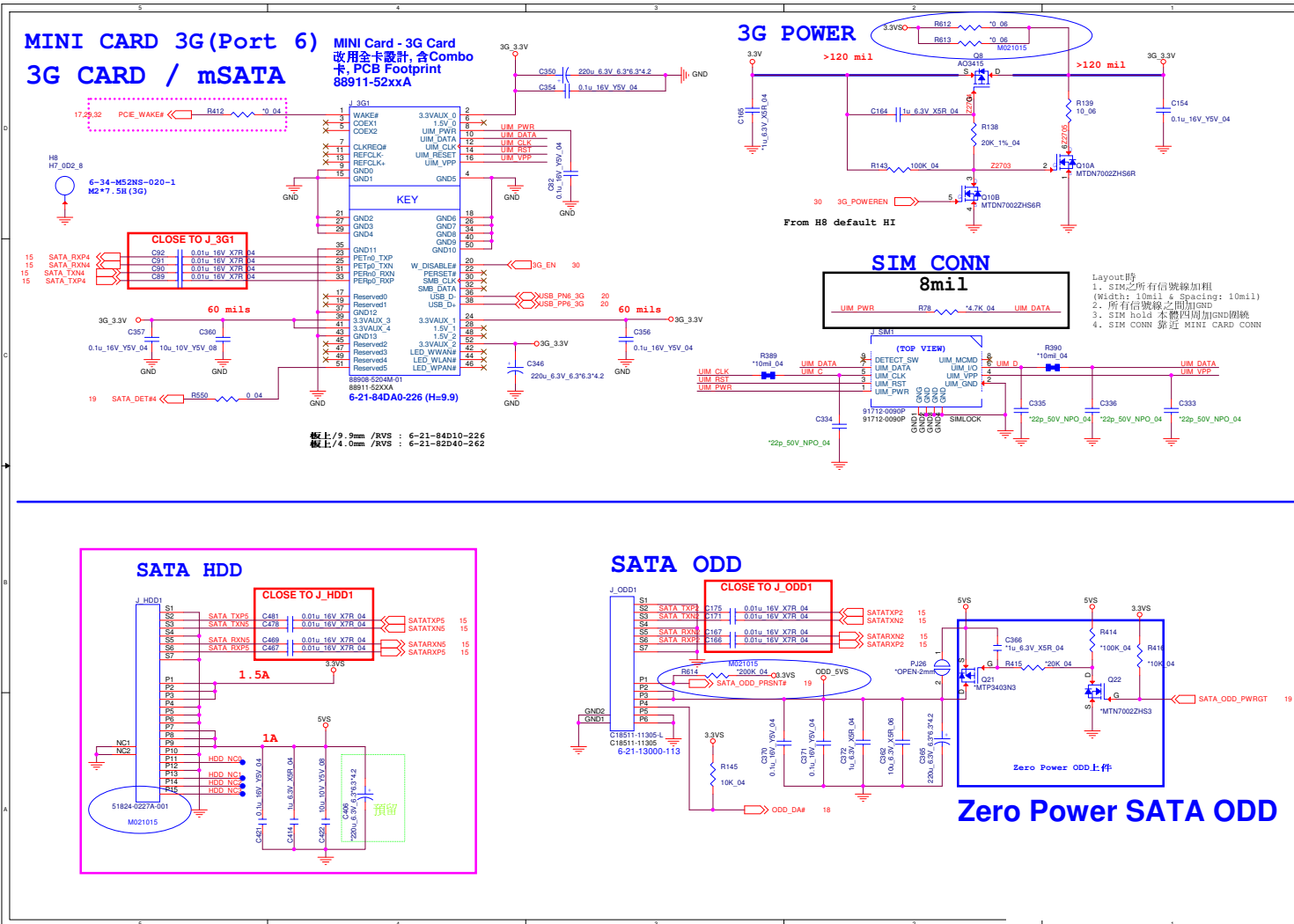

B.Schematic Diagrams

Sheet 28 of 44
3G, HDD, ODD

New Card, GSensor

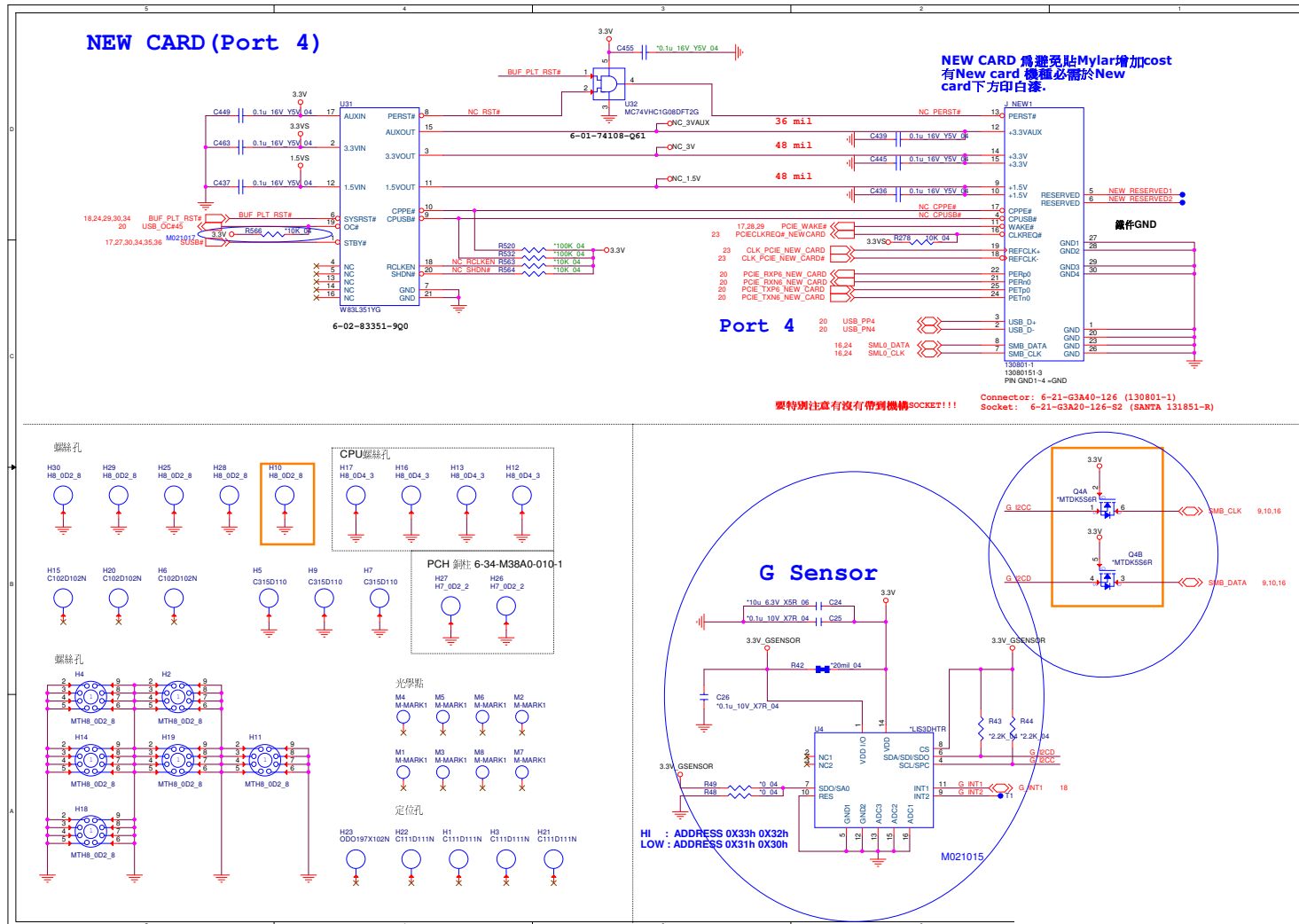

Sheet 32 of 44
New Card, GSensor

B.Schematic Diagrams

Fan, TP, Connector

Sheet 33 of 44
Fan, TP, Connector

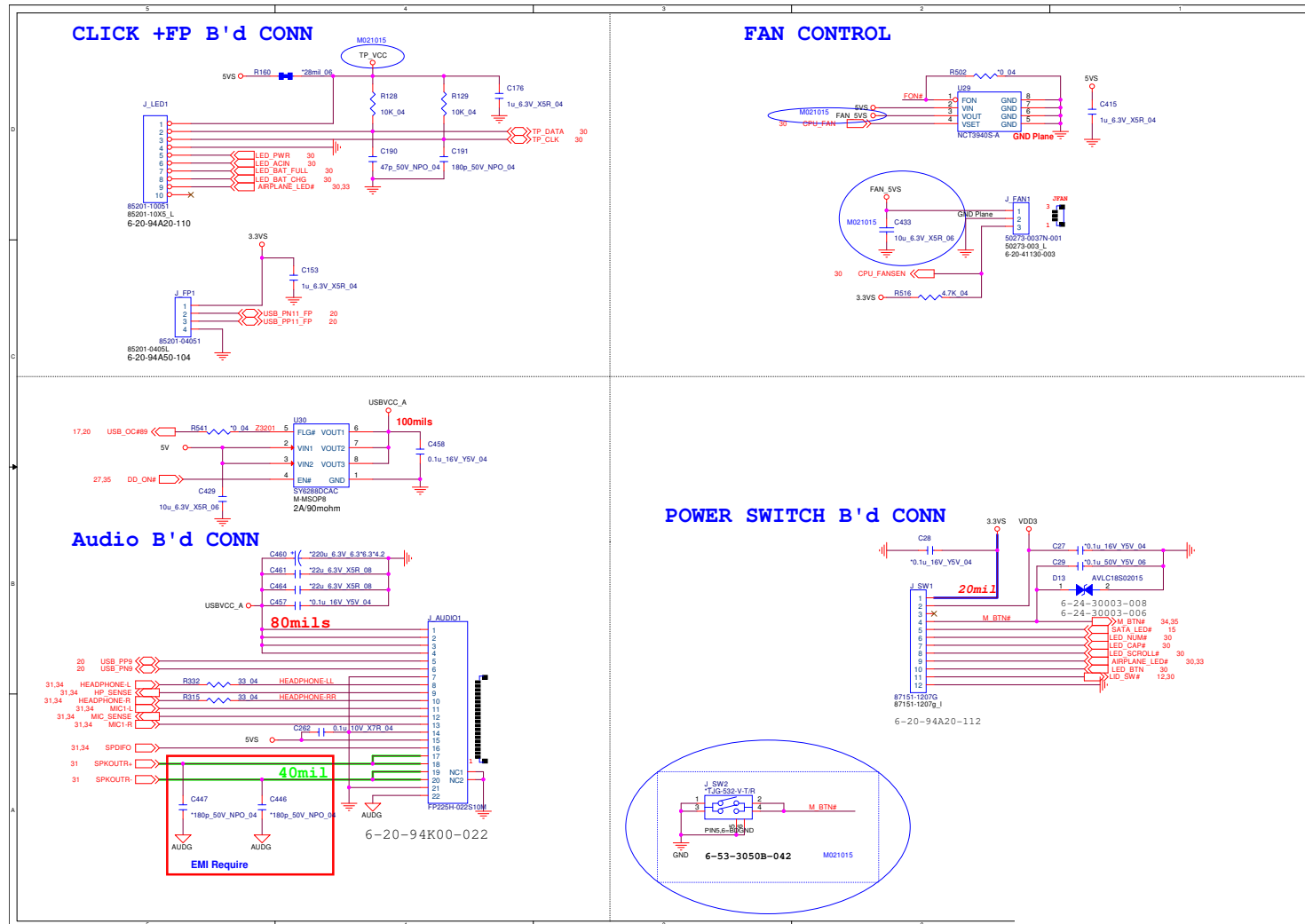

Docking Connector, COM Port

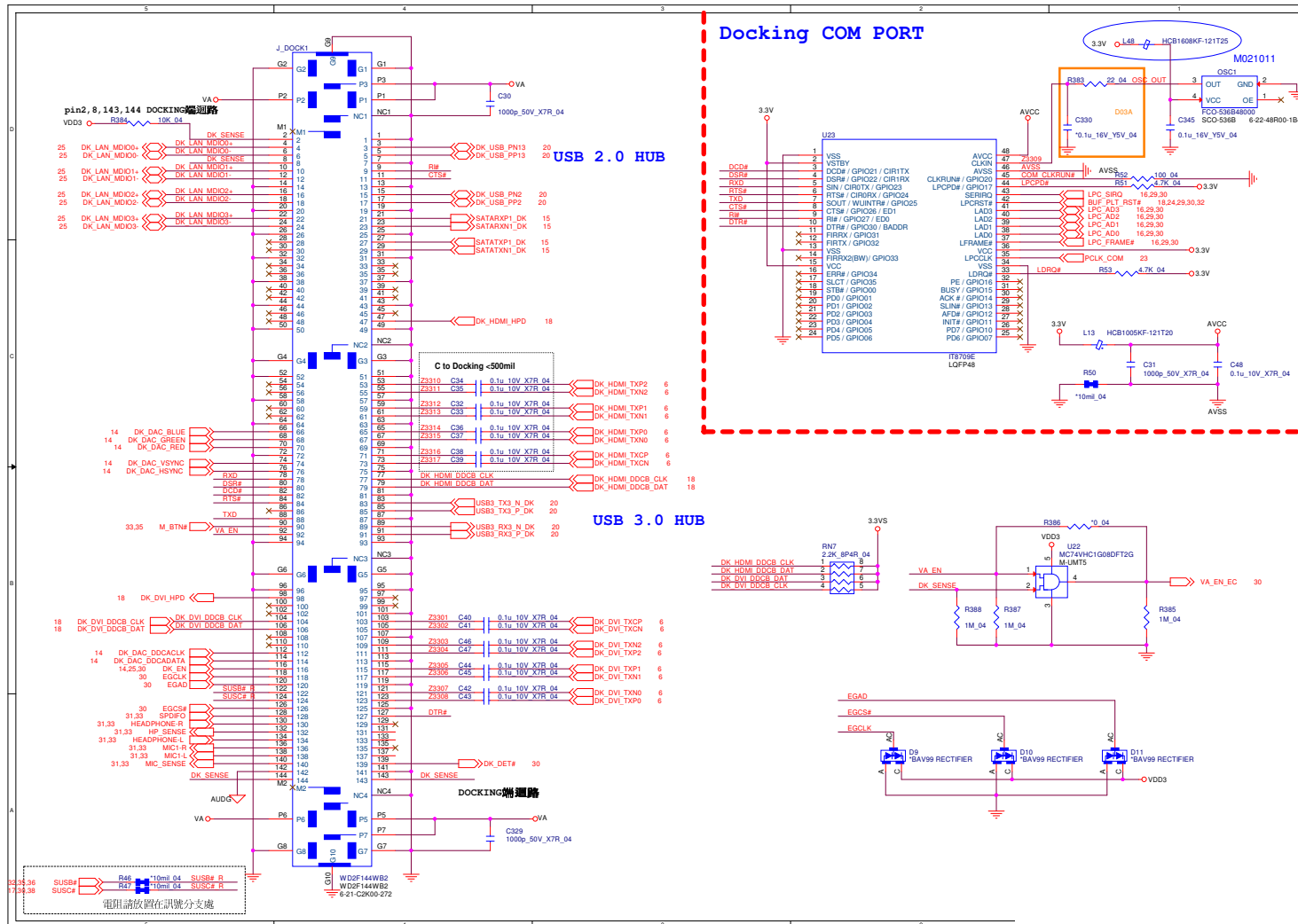

Sheet 34 of 44
Docking Connector, COM Port

B.Schematic Diagrams

Schematic Diagrams

5VS, 3VS, 3.3VM, 5VM

B.Schematic Diagrams

Sheet 35 of 44
5VS, 3VS, 3.3VM, 5VM

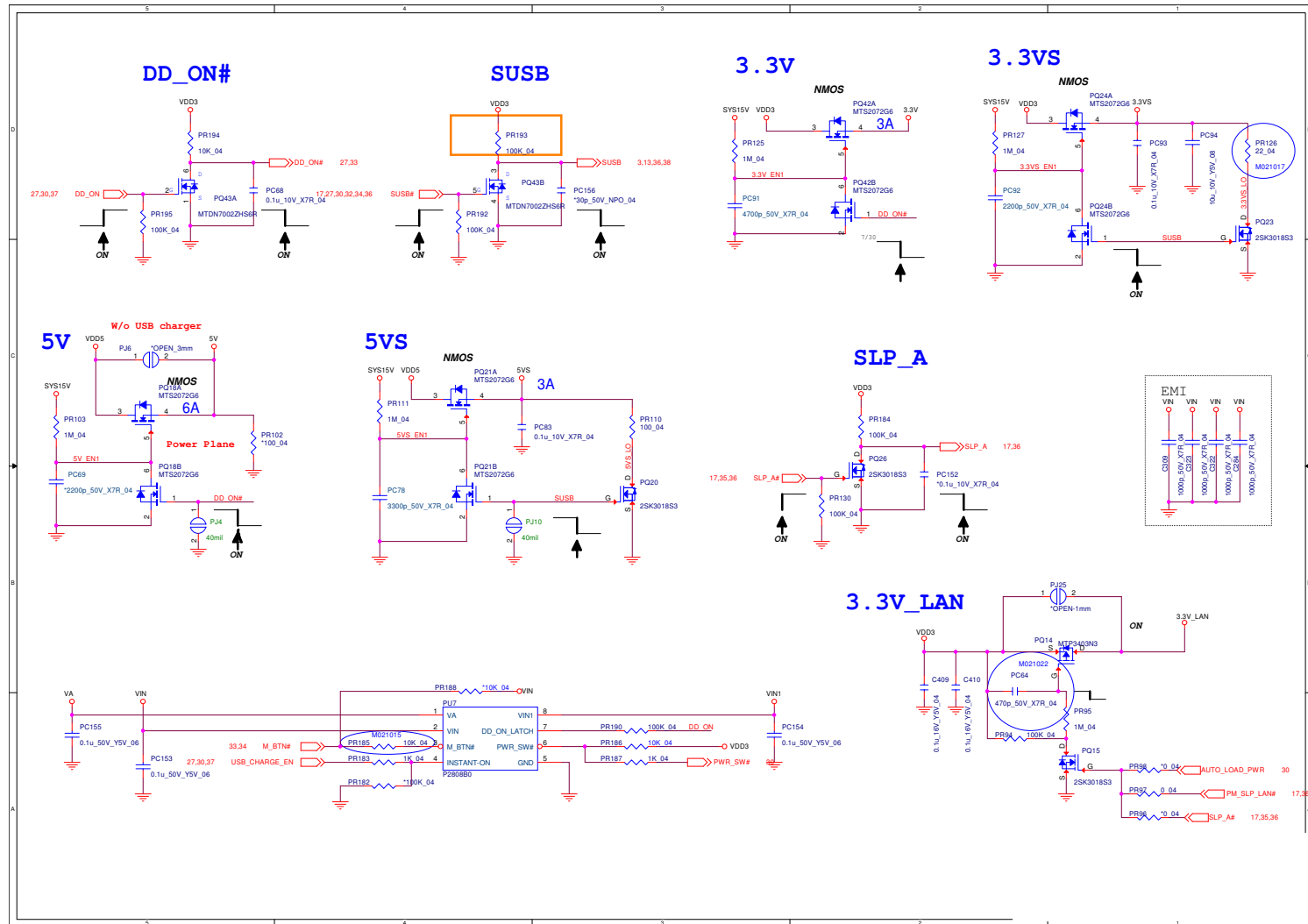

1.05V Series

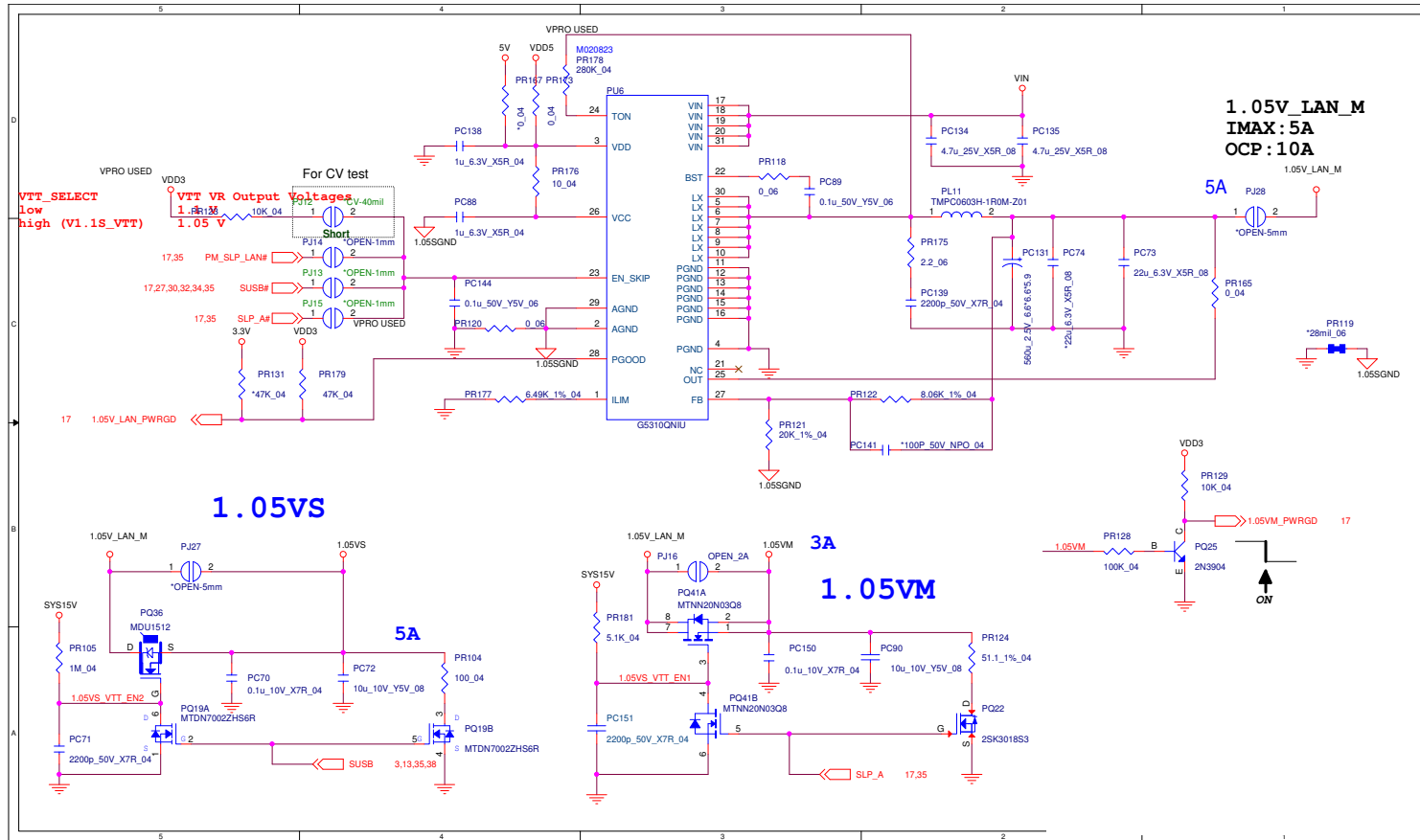

Sheet 36 of 44
1.05V Series

Power 1.5V, 1.35V, 0.75VS, 1.5VS

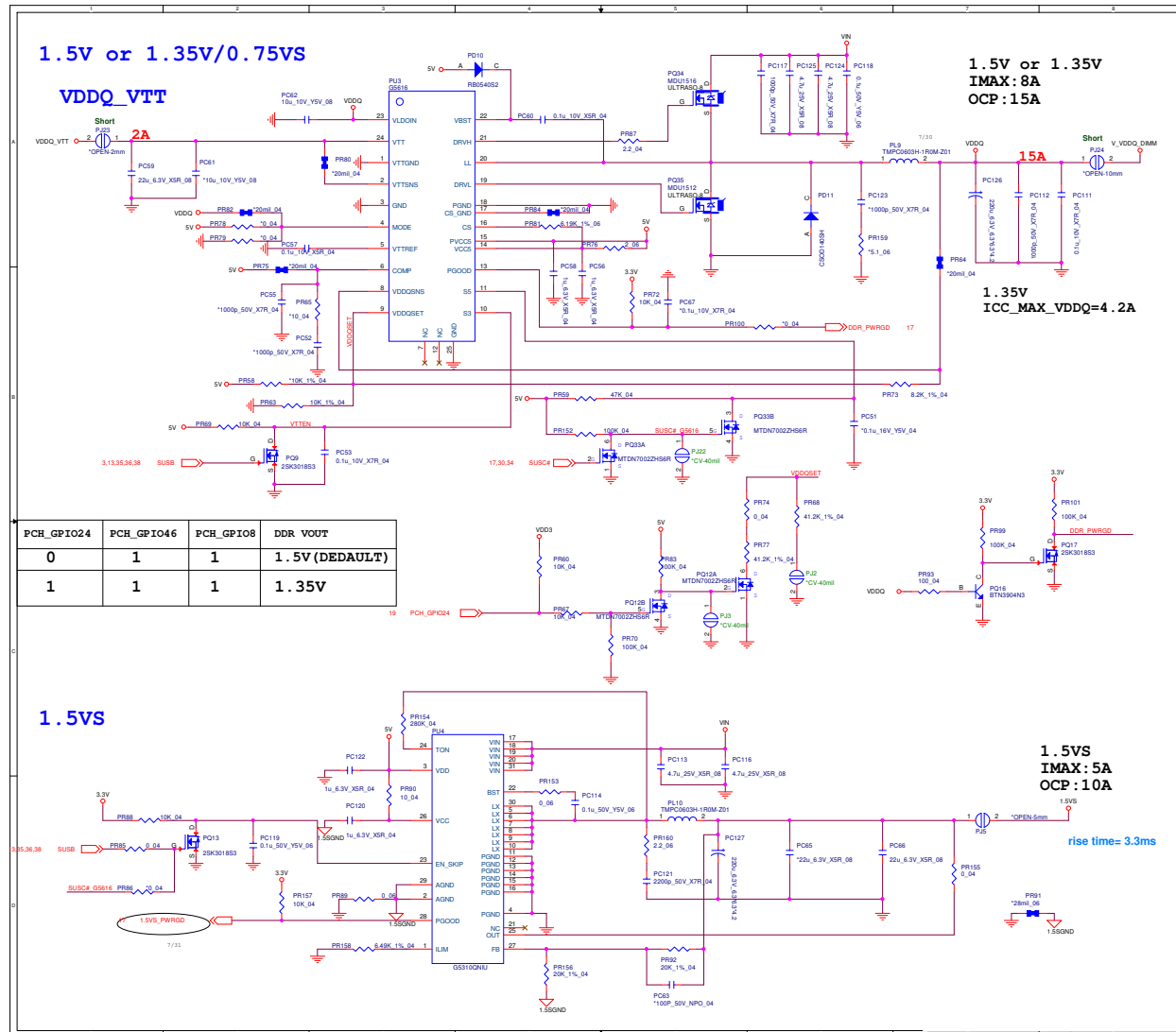

Sheet 38 of 44
Power 1.5V, 1.35V
0.75VS, 1.5VS

POWER V_CORE 1

Sheet 39 of 44
POWER V-CORE 1

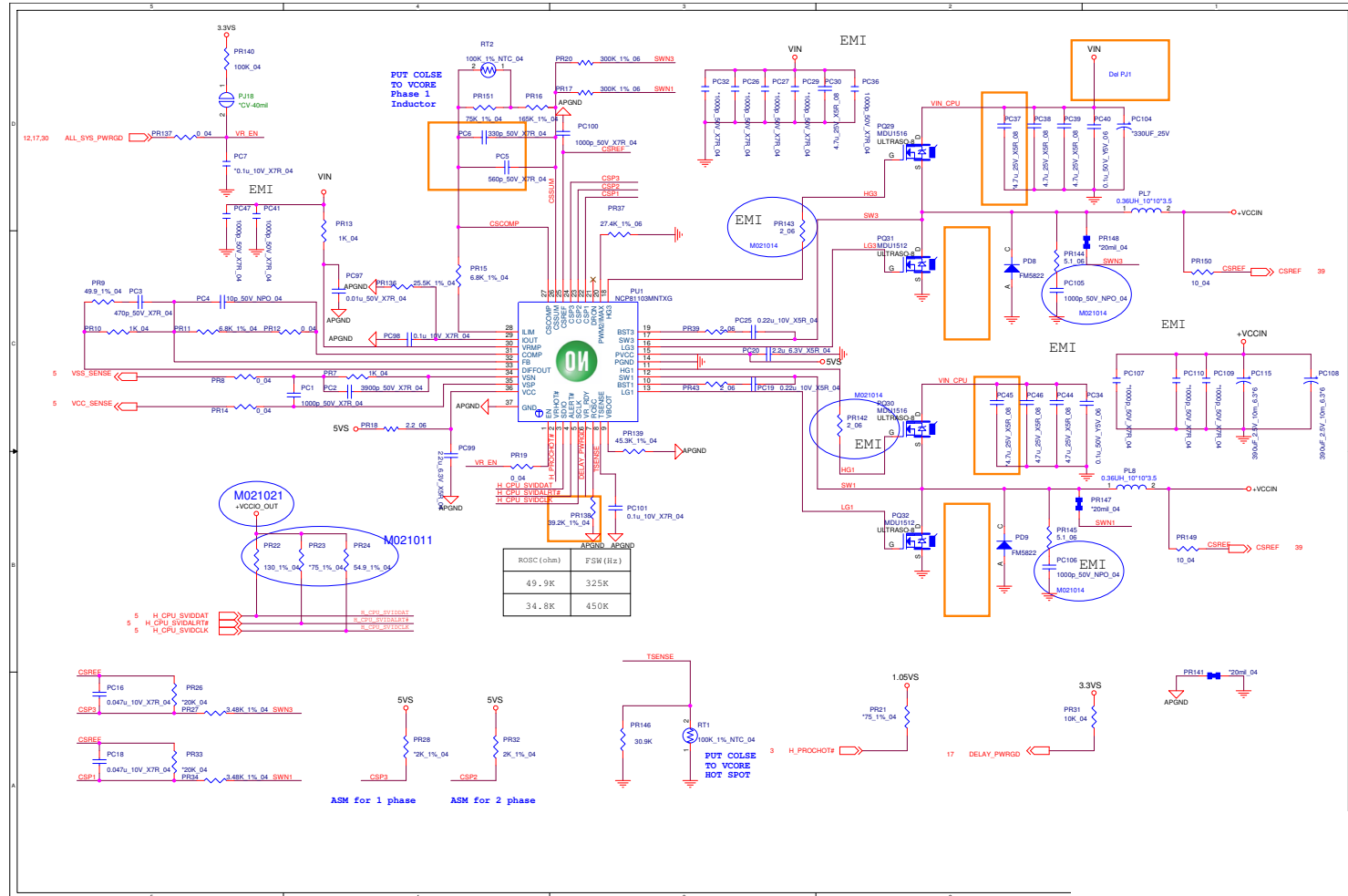

Audio Board

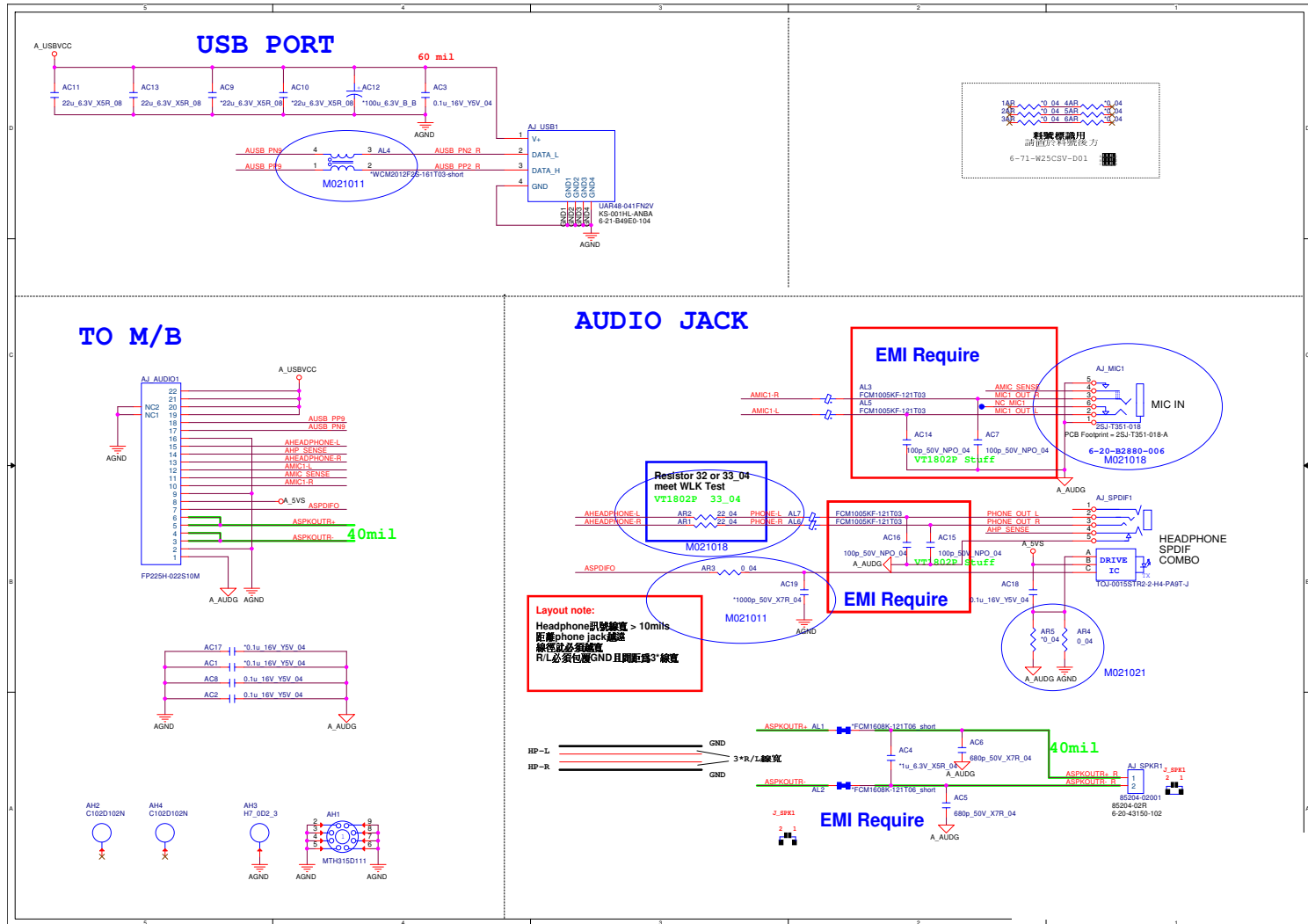

Sheet 41 of 44
Audio Board

Power Switch & LID Board

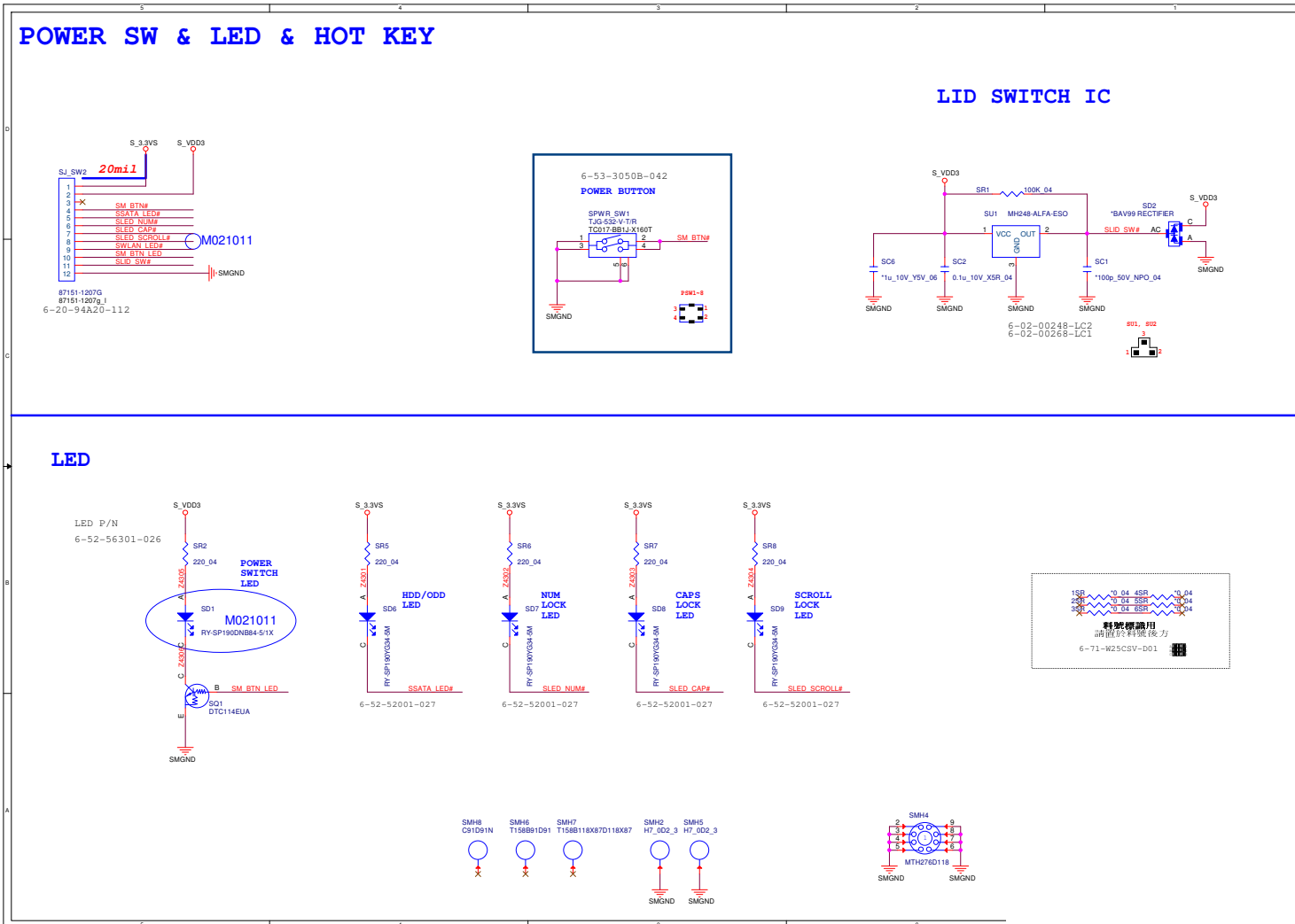

Sheet 42 of 44
Power Switch &
LID Board

FINGERPRINT BOARD

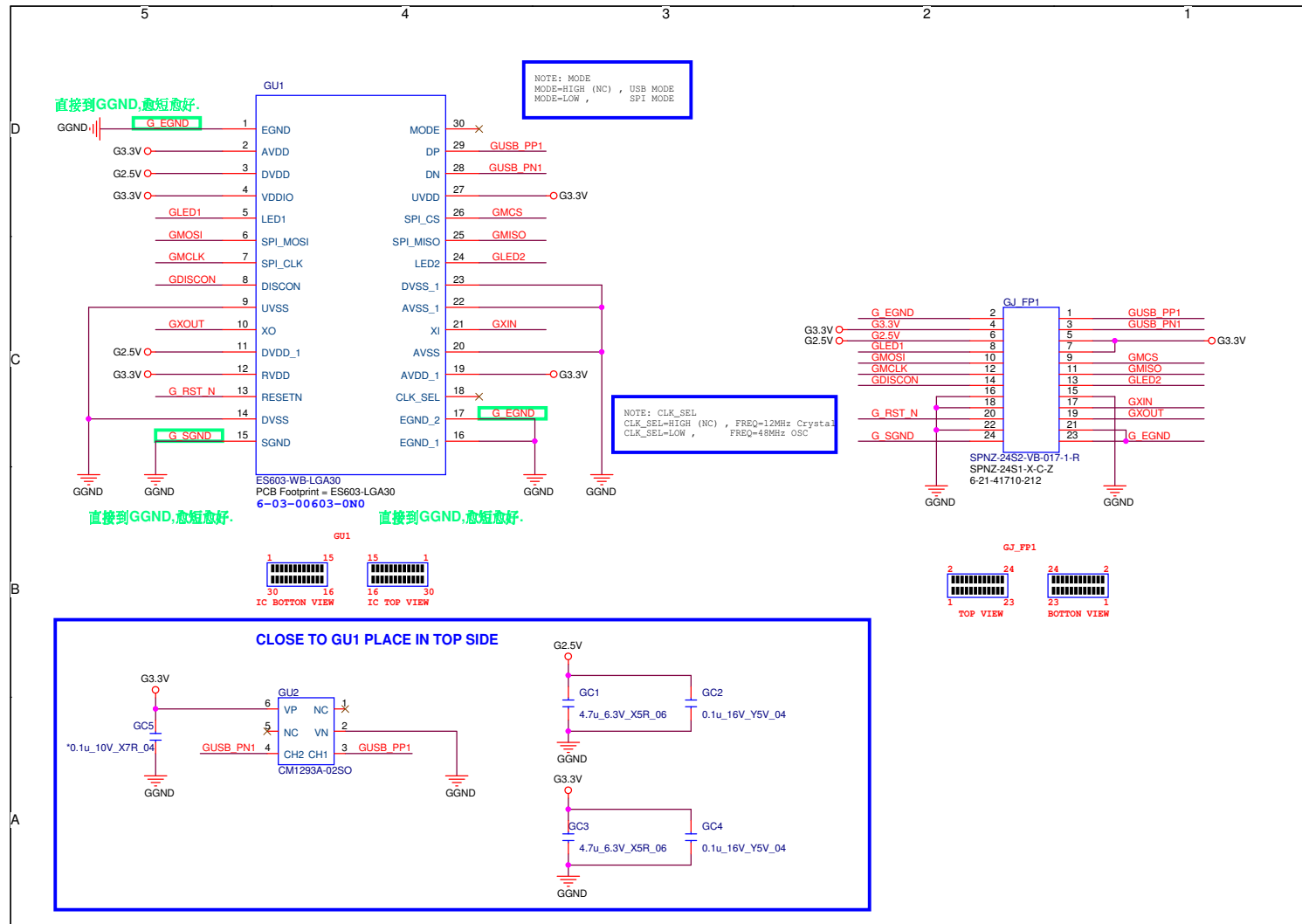

Sheet 44 of 44
FINGERPRINT BOARD

Schematic Diagrams

Appendix C: Updating the FLASH ROM BIOS

To update the FLASH ROM BIOS you must:

- Download the BIOS update from the web site.
- Unzip the files onto a bootable CD/DVD/USB Flash Drive.
- Reboot your computer from an external CD/DVD/USB Flash Drive.
- Use the flash tools to update the flash BIOS using the commands indicated below.
- Restart the computer booting from the HDD and press **F2** at startup enter the BIOS.
- Load setup defaults from the BIOS and save the default settings and exit the BIOS to restart the computer.
- After rebooting the computer you may restart the computer again and make any required changes to the default BIOS settings.

Download the BIOS

1. Go to www.clevo.com.tw and point to **E-Services** and click **E-Channel**.
2. Use your user ID and password to access the appropriate download area (BIOS), and download the latest BIOS files (the BIOS file will be contained in a batch file that may be run directly once unzipped) for your computer model (see sidebar for important information on BIOS versions).

Unzip the downloaded files to a bootable CD/DVD/ or USB Flash drive

1. Insert a bootable CD/DVD/USB flash drive into the CD/DVD drive/USB port of the computer containing the downloaded files.
2. Use a tool such as Winzip or Winrar to unzip all the BIOS files and refresh tools to your bootable CD/DVD/USB flash drive (you may need to create a bootable CD/DVD with the files using a 3rd party software).

Set the computer to boot from the external drive

1. With the bootable CD/DVD/USB flash drive containing the BIOS files in your CD/DVD drive/USB port, restart the computer and press **F2** (in most cases) to enter the BIOS.
2. Use the arrow keys to highlight the **Boot** menu.
3. Use the “+” and “-” keys to move boot devices up and down the priority order.
4. Make sure that the CD/DVD drive/USB flash drive is set first in the boot priority of the BIOS.
5. Press **F10** to save any changes you have made and exit the BIOS to restart the computer.



BIOS Version

Make sure you download the latest correct version of the BIOS appropriate for the computer model you are working on.

You should only download BIOS versions that are **V1.01.XX or higher** as appropriate for your computer model.

Note that BIOS versions are not backward compatible and therefore **you may not downgrade your BIOS to an older version** after upgrading to a later version (e.g if you upgrade a BIOS to ver 1.01.05, you **MAY NOT** then go back and flash the BIOS to ver 1.01.04).

BIOS Update

Use the flash tools to update the BIOS

1. Make sure you are not loading any memory management programs such as HIMEM by holding the **F8** key as you see the message “**Starting MS-DOS**”. You will then be prompted to give “**Y**” or “**N**” responses to the programs being loaded by DOS. Choose “**N**” for any memory management programs.
2. You should now be at the DOS prompt e.g: DISK C:\> (C is the designated drive letter for the CD/DVD drive/USB flash drive).
3. **Type the following command** at the DOS prompt:

C:\> Flash.bat

4. The utility will then proceed to flash the BIOS.
5. You should then be prompted to press any key to restart the system or turn the power off, and then on again but make sure you remove the CD/DVD/USB flash drive from the CD/DVD drive/USB port before the computer restarts.

Restart the computer (booting from the HDD)

1. With the CD/DVD/USB flash drive removed from the CD/DVD drive/USB port the computer should restart from the HDD.
2. Press **F2** as the computer restarts to enter the BIOS.
3. Use the arrow keys to highlight the **Exit** menu.
4. Select **Load Setup Defaults** (or press **F9**) and select “**Yes**” to confirm the selection.
5. Press **F10** to save any changes you have made and exit the BIOS to restart the computer.

Your computer is now running normally with the updated BIOS

You may now enter the BIOS and make any changes you require to the default settings.