

SERVICE MANUAL

W670RCQ

notebook



Notebook Computer

W670RCQ

Service Manual

Notice

The company reserves the right to revise this publication or to change its contents without notice. Information contained herein is for reference only and does not constitute a commitment on the part of the manufacturer or any subsequent vendor. They assume no responsibility or liability for any errors or inaccuracies that may appear in this publication nor are they in anyway responsible for any loss or damage resulting from the use (or misuse) of this publication.

This publication and any accompanying software may not, in whole or in part, be reproduced, translated, transmitted or reduced to any machine readable form without prior consent from the vendor, manufacturer or creators of this publication, except for copies kept by the user for backup purposes.

Brand and product names mentioned in this publication may or may not be copyrights and/or registered trademarks of their respective companies. They are mentioned for identification purposes only and are not intended as an endorsement of that product or its manufacturer.

Version 1.0
October 2015

Trademarks

Intel and Intel Core are trademarks of Intel Corporation.

Windows[®] is a registered trademark of Microsoft Corporation.

Other brand and product names are trademarks and /or registered trademarks of their respective companies.

About this Manual

This manual is intended for service personnel who have completed sufficient training to undertake the maintenance and inspection of personal computers.

It is organized to allow you to look up basic information for servicing and/or upgrading components of the *W670RCQ* series notebook PC.

The following information is included:

Chapter 1, Introduction, provides general information about the location of system elements and their specifications.

Chapter 2, Disassembly, provides step-by-step instructions for disassembling parts and subsystems and how to upgrade elements of the system.

Appendix A, Part Lists

Appendix B, Schematic Diagrams

Appendix C, Updating the FLASH ROM BIOS

IMPORTANT SAFETY INSTRUCTIONS

Follow basic safety precautions, including those listed below, to reduce the risk of fire, electric shock and injury to persons when using any electrical equipment:

1. Do not use this product near water, for example near a bath tub, wash bowl, kitchen sink or laundry tub, in a wet basement or near a swimming pool.
2. Avoid using a telephone (other than a cordless type) during an electrical storm. There may be a remote risk of electrical shock from lightning.
3. Do not use the telephone to report a gas leak in the vicinity of the leak.
4. Use only the power cord and batteries indicated in this manual. Do not dispose of batteries in a fire. They may explode. Check with local codes for possible special disposal instructions.
5. This product is intended to be supplied by a Listed Power Unit as follows:
 - AC Input of 100 - 240V, 50 - 60Hz, DC Output of 19.5V, 6.15A (**120** Watts) minimum AC/DC Adapter.

CAUTION

This Computer's Optical Device is a Laser Class 1 Product

FCC Statement

This device complies with Part 15 of the FCC Rules. Operation is subject to the following two conditions:

This device may not cause harmful interference.

This device must accept any interference received, including interference that may cause undesired operation.

Instructions for Care and Operation

The notebook computer is quite rugged, but it can be damaged. To prevent this, follow these suggestions:

1. **Don't drop it, or expose it to shock.** If the computer falls, the case and the components could be damaged.



2. **Keep it dry, and don't overheat it.** Keep the computer and power supply away from any kind of heating element. This is an electrical appliance. If water or any other liquid gets into it, the computer could be badly damaged.

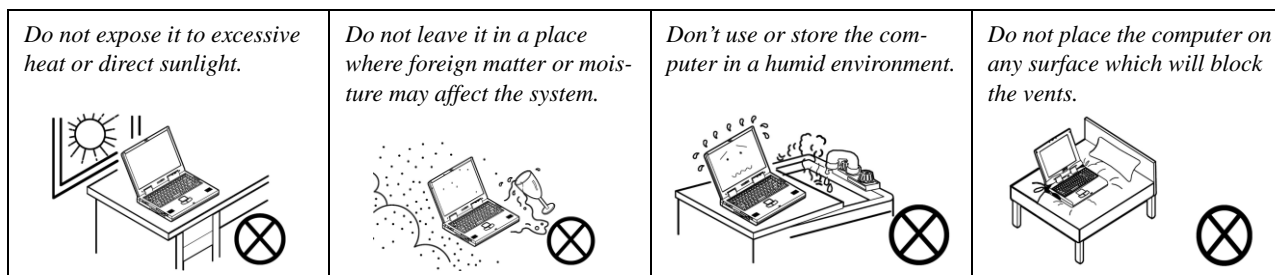

3. **Follow the proper working procedures for the computer.** Shut the computer down properly and don't forget to save your work. Remember to periodically save your data as data may be lost if the battery is depleted.

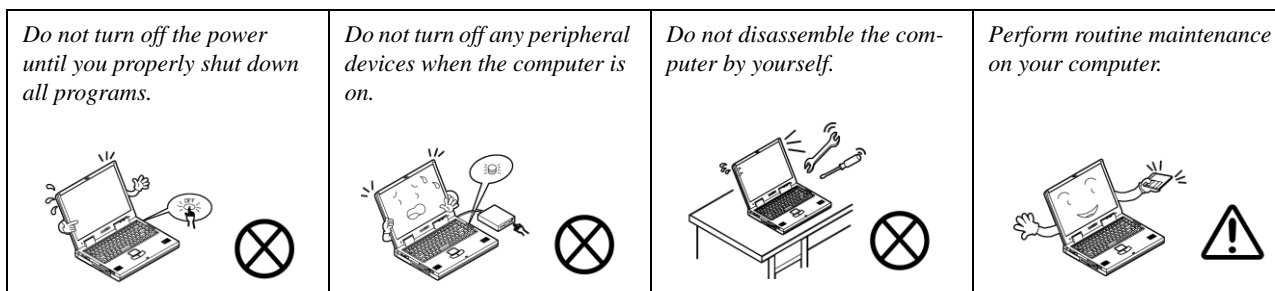

4. **Avoid interference.** Keep the computer away from high capacity transformers, electric motors, and other strong magnetic fields. These can hinder proper performance and damage your data.
5. **Take care when using peripheral devices.**

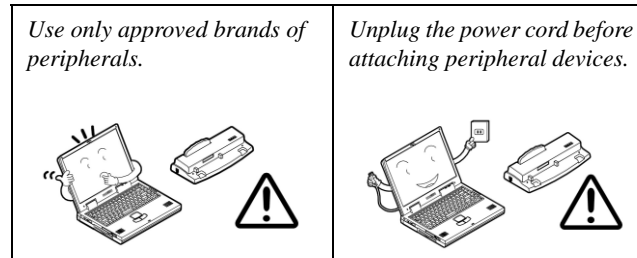

Power Safety

The computer has specific power requirements:

- Only use a power adapter approved for use with this computer.
- Your AC adapter may be designed for international travel but it still requires a steady, uninterrupted power supply. If you are unsure of your local power specifications, consult your service representative or local power company.
- The power adapter may have either a 2-prong or a 3-prong grounded plug. The third prong is an important safety feature; do not defeat its purpose. If you do not have access to a compatible outlet, have a qualified electrician install one.
- When you want to unplug the power cord, be sure to disconnect it by the plug head, not by its wire.
- Make sure the socket and any extension cord(s) you use can support the total current load of all the connected devices.
- Before cleaning the computer, make sure it is disconnected from any external power supplies.

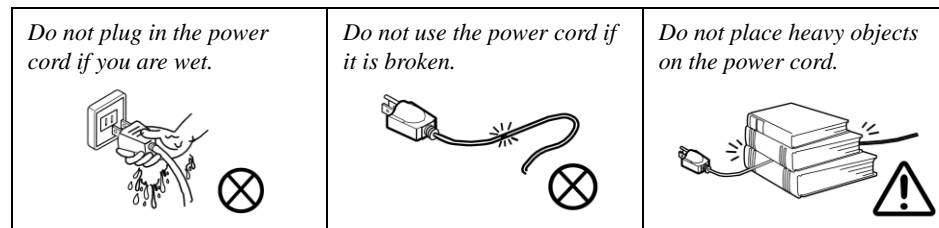

Power Safety Warning

Before you undertake any upgrade procedures, make sure that you have turned off the power, and disconnected all peripherals and cables (including telephone lines and power cord). It is advisable to also remove your battery in order to prevent accidentally turning the machine on.

Battery Precautions

- Only use batteries designed for this computer. The wrong battery type may explode, leak or damage the computer.
- Do not continue to use a battery that has been dropped, or that appears damaged (e.g. bent or twisted) in any way. Even if the computer continues to work with a damaged battery in place, it may cause circuit damage, which may possibly result in fire.
- Recharge the batteries using the notebook's system. Incorrect recharging may make the battery explode.
- Do not try to repair a battery pack. Refer any battery pack repair or replacement to your service representative or qualified service personnel.
- Keep children away from, and promptly dispose of a damaged battery. Always dispose of batteries carefully. Batteries may explode or leak if exposed to fire, or improperly handled or discarded.
- Keep the battery away from metal appliances.
- Affix tape to the battery contacts before disposing of the battery.
- Do not touch the battery contacts with your hands or metal objects.

Battery Guidelines

The following can also apply to any backup batteries you may have.

- If you do not use the battery for an extended period, then remove the battery from the computer for storage.
- Before removing the battery for storage charge it to 60% - 70%.
- Check stored batteries at least every 3 months and charge them to 60% - 70%.



Battery Disposal

The product that you have purchased contains a rechargeable battery. The battery is recyclable. At the end of its useful life, under various state and local laws, it may be illegal to dispose of this battery into the municipal waste stream. Check with your local solid waste officials for details in your area for recycling options or proper disposal.

Caution

Danger of explosion if battery is incorrectly replaced. Replace only with the same or equivalent type recommended by the manufacturer. Discard used battery according to the manufacturer's instructions.

Battery Level

Click the battery icon  in the taskbar to see the current battery level and charge status. A battery that drops below a level of 10% will not allow the computer to boot up. Make sure that any battery that drops below 10% is recharged within one week.

Related Documents

You may also need to consult the following manual for additional information:

User's Manual on CD/DVD

This describes the notebook PC's features and the procedures for operating the computer and its ROM-based setup program. It also describes the installation and operation of the utility programs provided with the notebook PC.

System Startup

1. Remove all packing materials.
2. Place the computer on a stable surface.
3. Insert the battery and make sure it is locked in position.
4. Securely attach any peripherals you want to use with the computer (e.g. keyboard and mouse) to their ports.
5. Attach the AC/DC adapter to the DC-In jack on the left of the computer, then plug the AC power cord into an outlet, and connect the AC power cord to the AC/DC adapter.
6. Use one hand to raise the lid/LCD to a comfortable viewing angle (do not exceed 130 degrees); use the other hand (as illustrated in Figure 1) to support the base of the computer (**Note: Never** lift the computer by the lid/LCD).
7. Press the power button to turn the computer "on".

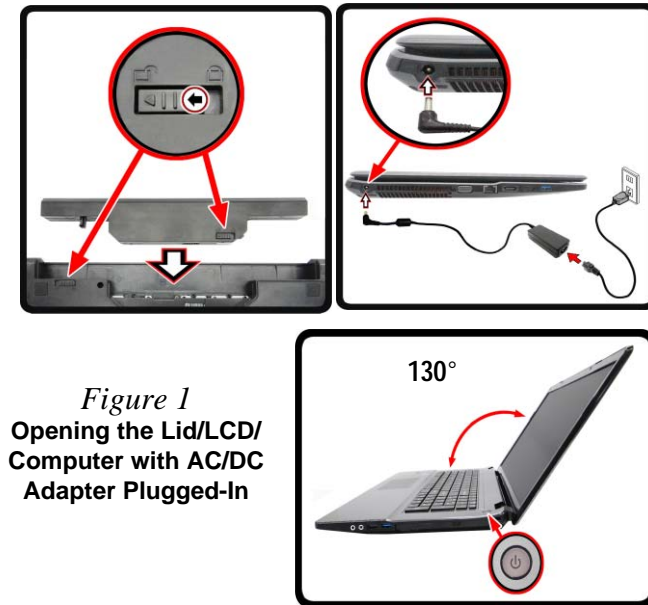



Figure 1
**Opening the Lid/LCD/
Computer with AC/DC
Adapter Plugged-In**



Shut Down

Note that you should always shut your computer down by clicking **Settings** in the **Charms Bar** (use the **Windows Logo Key**  + **C** key combination to access the Charms Bar) and choosing **Shut down** from the **Power** menu.

This will help prevent hard disk or system problems.

Contents

Introduction1-1

Overview	1-1
Specifications	1-2
External Locator - Top View with LCD Panel Open	1-4
External Locator - Front & Right Side Views	1-5
External Locator - Left Side & Rear View	1-6
External Locator - Bottom View	1-7
Mainboard Overview - Top (Key Parts)	1-8
Mainboard Overview - Bottom (Key Parts)	1-9
Mainboard Overview - Top (Connectors)	1-10
Mainboard Overview - Bottom (Connectors)	1-11

Disassembly2-1

Overview	2-1
Maintenance Tools	2-2
Connections	2-2
Maintenance Precautions	2-3
Disassembly Steps	2-4
Removing the Battery	2-5
Removing the Keyboard	2-6
Removing the Hard Disk Drive	2-7
Removing the Optical (CD/DVD) Device	2-10
Removing the System Memory (RAM)	2-12
Removing the Wireless LAN Module	2-14
Wireless LAN, Combo, 3G & LTE Module Cables	2-15
Removing the SSD Module	2-16
Removing the CCD	2-17

Part ListsA-1

Part List Illustration Location	A-2
Top	A-3

Bottom	A-4
DVD DUAL	A-5
HDD	A-6
2nd HDD	A-7
LCD	A-8

Schematic Diagrams.....B-1

System Block Diagram	B-2
Processor 1/7	B-3
Processor 2/7	B-4
Processor 3/7	B-5
Processor 4/7	B-6
Processor 5/7	B-7
Processor 6/7	B-8
Processor 7/7	B-9
DDR3 CHA SO-DIMM_0	B-10
DDR3 CHB SO-DIMM_0	B-11
PS8625	B-12
PANEL, INVERTER	B-13
VGA PCI-E Interface	B-14
VGA Frame Buffer Interface	B-15
VGA Frame Buffer A	B-16
VGA Frame Buffer C	B-17
VGA I/O	B-18
VGA NVVDD Decoupling	B-19
CRT	B-20
PCH 1/9	B-21
PCH 2/9	B-22
PCH 3/9	B-23
PCH 4/9	B-24
PCH 5/9	B-25

Preface

PCH 6/9	B-26	Set the computer to boot from the external drive	C-1
PCH 7/9	B-27	Use the flash tools to update the BIOS	C-2
PCH 8/9	B-28	Restart the computer (booting from the HDD)	C-2
PCH 9/9	B-29		
M.2 3G + M.2 SATA	B-30		
M.2 WLAN+BT, PCIE4X SSD	B-31		
USB3.0, LED	B-32		
Card Reader (RTL8411B)	B-33		
HDD, TP, Audio, USB	B-34		
HDMI	B-35		
AUDIO CODEC ALC269 VC2	B-36		
KBC-ITE IT8587	B-37		
5V, 5VS, 3.3V, 3.3VS, 3.3VA	B-38		
1.0V, VCCIO	B-39		
VDD3, VDD5	B-40		
DDR3L 1.35V / 0.75VS	B-41		
POWER VCORE	B-42		
VCC_Core & VCCSA	B-43		
1.0DX_VCCSTG / VCCSFR_OC	B-44		
VCCGT	B-45		
VCCGT Output Stage	B-46		
AC_In, Charger	B-47		
N16P/S, NVVDD, PEX, FBVDDQ	B-48		
USB Charge, CCD, TPM, Power Conn	B-49		
Audio Board	B-50		
Power Switch Board	B-51		
ODD to HDD Board	B-52		
Updating the FLASH ROM BIOS.....	C-1		
Download the BIOS	C-1		
Unzip the downloaded files to a bootable CD/DVD/ or			
USB Flash drive	C-1		

Chapter 1: Introduction

Overview

This manual covers the information you need to service or upgrade the **W670RCQ** series notebook computer. Information about operating the computer (e.g. getting started, and the *Setup* utility) is in the *User's Manual*. Information about drivers (e.g. VGA & audio) is also found in the *User's Manual*. The manual is shipped with the computer.

Operating systems (e.g. *Windows 8.1*, etc.) have their own manuals as do application softwares (e.g. word processing and database programs). If you have questions about those programs, you should consult those manuals.

The **W670RCQ** series notebook is designed to be upgradeable. See *Disassembly on page 2 - 1* for a detailed description of the upgrade procedures for each specific component. Please take note of the warning and safety information indicated by the “” symbol.

The balance of this chapter reviews the computer's technical specifications and features.

Introduction

Specifications



Latest Specification Information

The specifications listed here are correct at the time of sending them to the press. Certain items (particularly processor types/speeds) may be changed, delayed or updated due to the manufacturer's release schedule. Check with your service center for more details.



CPU

The CPU is not a user serviceable part. Accessing the CPU in any way may violate your warranty.

Processor Options

Intel® Core™ i7 Processor

i7-6700HQ (2.60GHz)

8MB Smart Cache, 14nm, DDR3L-1600MHz, TDP 45W

Intel® Core™ i5 Processor

i5-6300HQ (2.30GHz)

6MB Smart Cache, 14nm, DDR3L-1600MHz, TDP 45W

Intel® Core™ i3 Processor

i3-6100H (2.70GHz)

3MB Smart Cache, 14nm, DDR3L-1600MHz, TDP 35W

Core Logic

Intel® HM170 Chipset

BIOS

64Mb SPI Flash ROM

AMI BIOS

Memory

Two 204 Pin SO-DIMM Sockets Supporting **DDR3L**

1600MHz Memory

Memory Expandable up to 16GB

(The real memory operating frequency depends on the FSB of the processor.)

Storage

One Changeable 2.5" 9.5mm/7.0mm (h) SATA HDD/SSD

(Factory Option) One 12.7mm(h) Optical Device Type Drive (Super Multi Drive)

(Factory Option) 2.5" 9.5mm 2nd HDD/SSD caddy

(Factory Option) One M.2 **SATA/PCIe Gen3 x4** Solid State Drive (SSD)

LCD Options

17.3" (43.94cm), 16:9, HD+ (1600x900)/FHD (1920x1080)

Video Adapter (Design II)

Intel® Integrated GPU and NVIDIA® Discrete GPU

Supports Microsoft Hybrid Graphics

Intel Integrated GPU

Intel® HD Graphics 530

Dynamic Frequency

Intel Dynamic Video Memory Technology

Microsoft DirectX®12 Compatible

NVIDIA® Discrete GPU

NVIDIA® GeForce GTX 950M

2GB GDDR3 Video RAM on board

Microsoft DirectX® 12 Compatible

Audio

High Definition Audio Compliant Interface

2 * Built-In Speakers

Built-In Microphone

Sound Blaster™ Cinema 2

Security

Security (Kensington® Type) Lock Slot

BIOS Password

Intel PTT for systems without hardware TPM

(Factory Option) TPM v 2.0

Keyboard

Full-size "WinKey" keyboard (with numeric keypad)

(Factory Option) Full-size "WinKey" **Illuminated White-LED** Keyboard (with numeric keypad)

Pointing Device

Built-in Touchpad

Interface

One USB 2.0 Port
 Three USB 3.0 Ports
 One HDMI-Out Port
 One External Monitor Port
 One Headphone-Out Jack
 One Microphone-In Jack
 One RJ-45 LAN Jack
 One DC-in Jack

M.2 Slots

Slot 1 for **WLAN and Bluetooth** Combo Module
 Slot 2 for **SATA/PCIe Gen3 x4 SSD**

Card Reader

Embedded Multi-In-1 Card Reader
 MMC (MultiMedia Card) / RS MMC
 SD (Secure Digital) / Mini SD / SDHC/ SDXC
 MS (Memory Stick) / MS Pro / MS Duo

Communication

Built-In Gigabit Ethernet LAN
 1.0M HD PC Camera Module
(Factory Option) 2.0M FHD PC Camera Module

WLAN/ Bluetooth M.2 Modules:

(Factory Option) Intel® Wireless-AC 8260 Wireless LAN
(802.11ac) + Bluetooth **4.1**
(Factory Option) Intel® Wireless-AC 7265 Wireless LAN
(802.11ac) + Bluetooth **4.0**
(Factory Option) Intel® Wireless-AC 3165 Wireless LAN
(802.11ac) + Bluetooth **4.0**
(Factory Option) Intel® Wireless-N 7265 Wireless LAN
(802.11b/g/n) + Bluetooth **4.0**
(Factory Option) Third-Party Wireless LAN **(802.11b/g/n)** +
 Bluetooth **4.0**

Environmental Spec**Temperature**

Operating: 5°C - 35°C
 Non-Operating: -20°C - 60°C

Relative Humidity

Operating: 20% - 80%
 Non-Operating: 10% - 90%

Power (Design II)

Full Range AC/DC Adapter
 AC Input: 100 - 240V, 50 - 60Hz
 DC Output: 19.5V, 6.15A (**120W**)

(Factory Option) Removable 6 Cell Smart Lithium-Ion Battery Pack, 62.16WH

(Factory Option) Removable 6 Cell Smart Lithium-Ion Battery Pack, 48.84WH

Dimensions & Weight

413mm (w) * 272.8mm (d) * 36.4mm (h)
3.1kg (Barebone with ODD and 62.16WH Battery)

Introduction

Figure 1
Top View

1. PC Camera
2. Built-In Microphone
3. *PC Camera LED
**When the PC camera is in use, the LED will be illuminated in red.*
4. LCD
5. Power Button
6. LED Indicator
7. Keyboard
8. Touchpad & Buttons

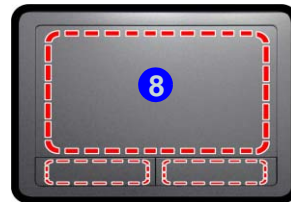

Note that the Touchpad and Buttons valid operational area is that indicated within the red dotted lines.

External Locator - Top View with LCD Panel Open

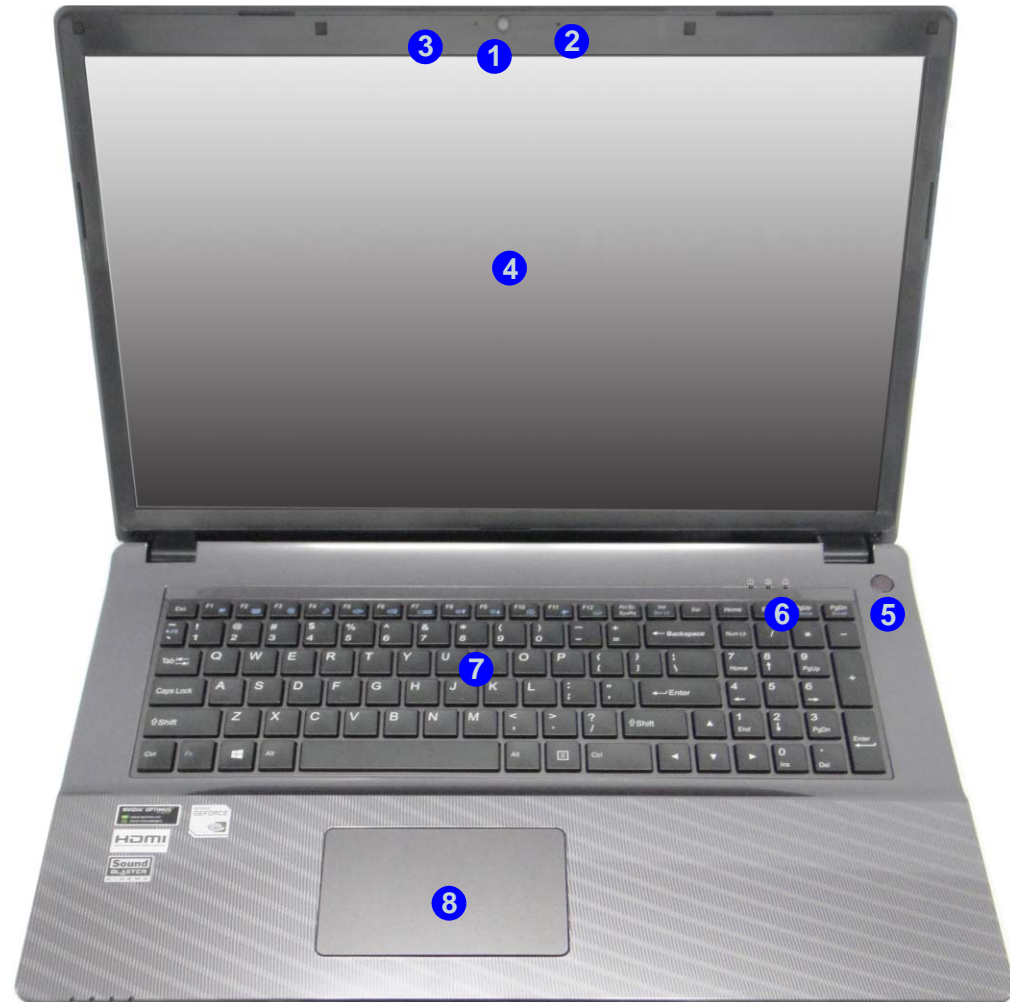

External Locator - Front & Right Side Views

FRONT VIEW



Figure 2
Front View

1. LED Indicator
2. Multi-in-1 Card Reader

RIGHT SIDE VIEW



Figure 3
Right Side View

1. Microphone-In Jack
2. Headphone-Out Jack
3. USB Ports
4. Optical Device Drive Bay
5. Emergency Eject Hole
6. Security Lock Slot

Introduction

External Locator - Left Side & Rear View

Figure 4
Left Side View

1. DC-In Jack
2. Vent
3. External Monitor Port
4. RJ-45 LAN Jack
5. USB 3.0 Ports
6. HDMI-Out Port

LEFT SIDE VIEW



Figure 5
Rear View

1. Battery

REAR VIEW



External Locator - Bottom View

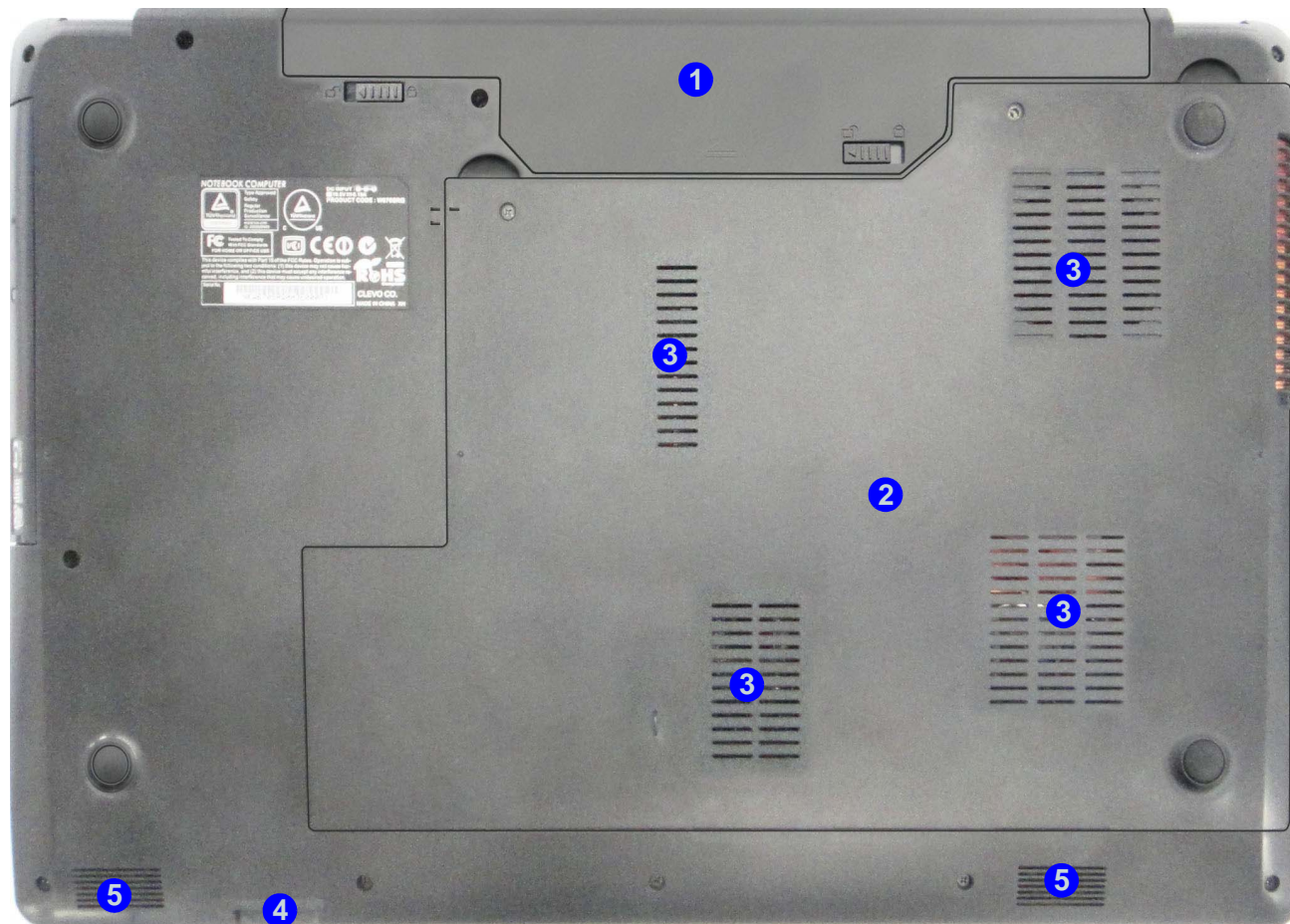

Figure 6
Bottom View

1. Battery
2. Component Bay Cover
3. Vent
4. Multi-in-1 Card Reader
5. Speakers



Overheating

To prevent your computer from overheating, make sure nothing blocks any vent while the computer is in use.

Figure 7
Mainboard Top
Key Parts

Mainboard Overview - Top (Key Parts)

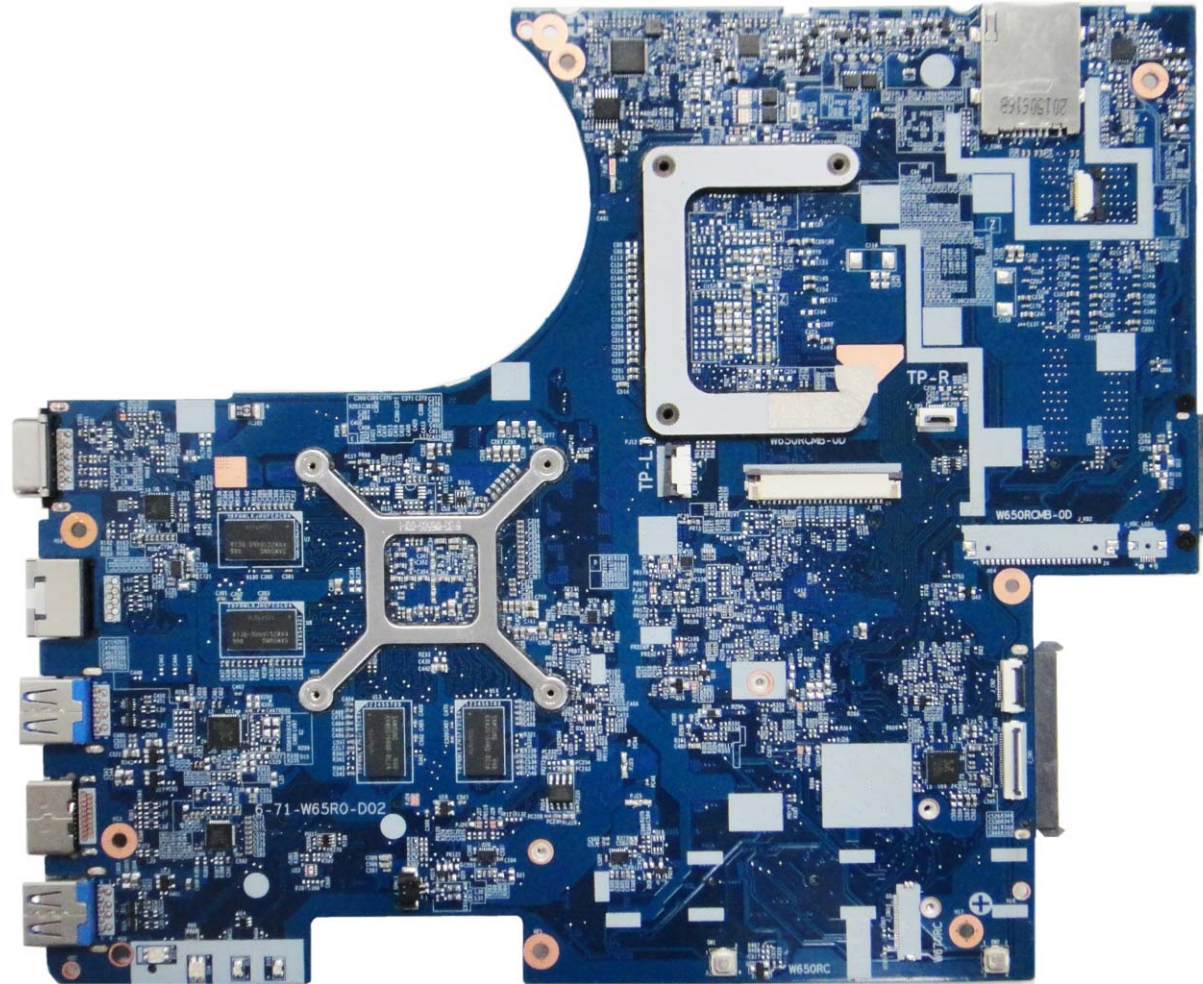

Mainboard Overview - Bottom (Key Parts)

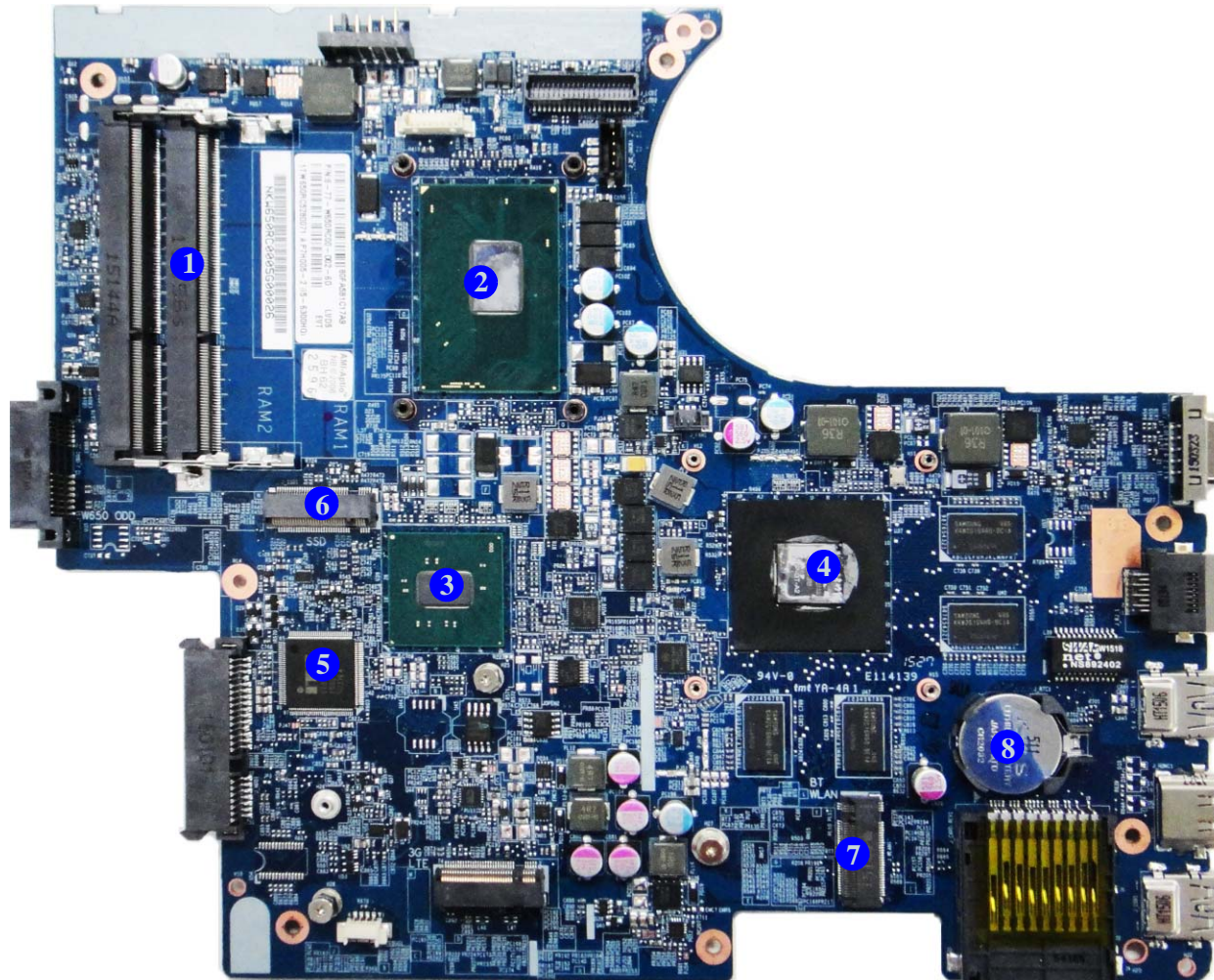

Figure 8
**Mainboard Bottom
Key Parts**

1. Memory Slots
DDR3L SO-DIMM
2. CPU Socket (no
CPU installed)
3. Platform Controller
Hub
4. VGA Chip
5. KBC-ITE IT8587
6. Mini-Card
Connector (SSD
Module)
7. Mini-Card
Connector (WLAN
Module)
8. CMOS Battery

Introduction

Figure 9
**Mainboard Top
Connectors**

Mainboard Overview - Top (Connectors)

1. External Monitor Port
2. RJ-45 LAN Jack
3. Combo eSATA/
USB Port 3.0
4. HDMI-Out Port
5. USB Port 3.0
Connector
6. Speaker Cable
Connector
7. Keyboard Cable
Connector
8. Power Board
Connector
9. Touchpad Cable
Connector
10. Keyboard FPC
Connector
11. Power Board
Connector

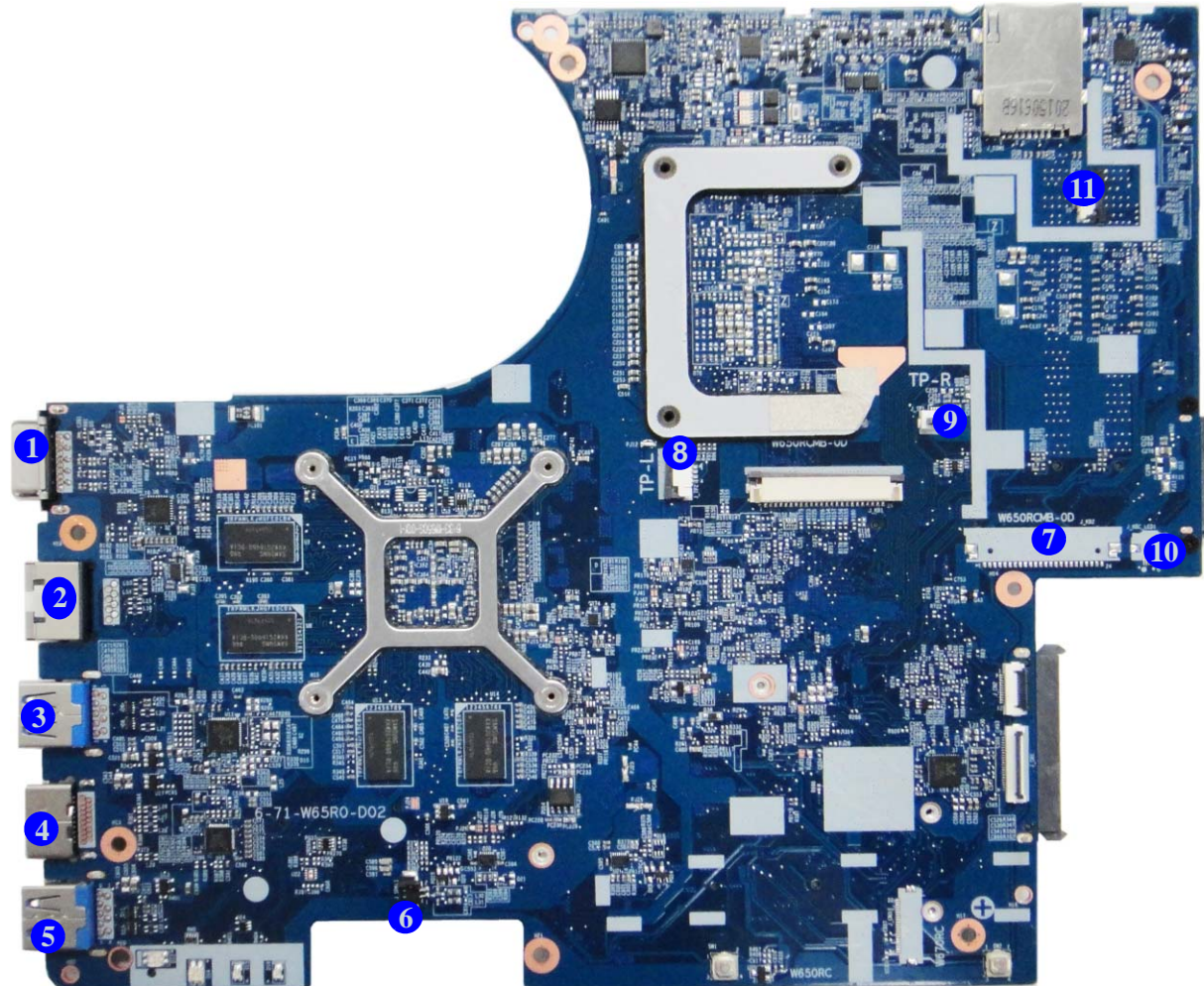

Mainboard Overview - Bottom (Connectors)

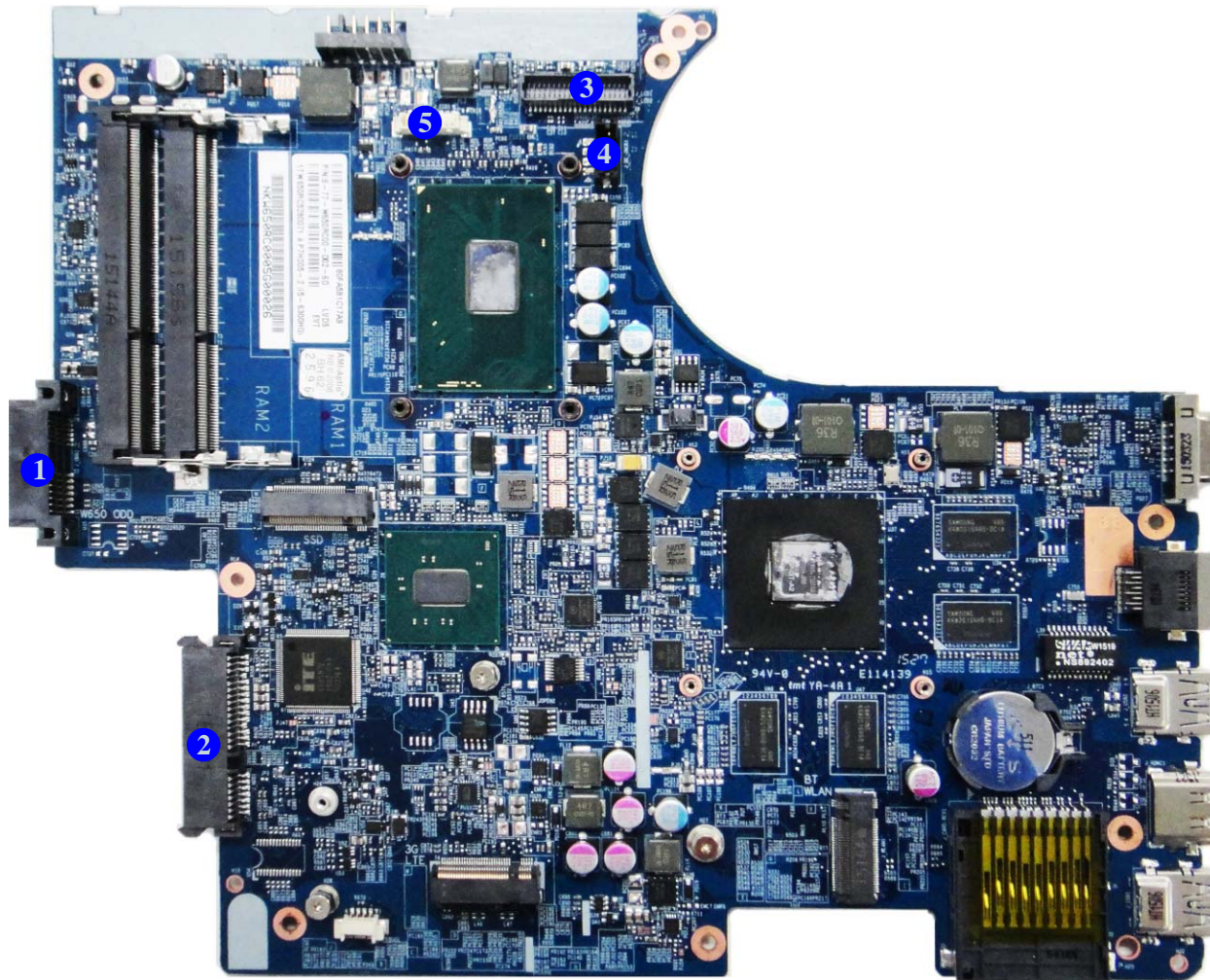

Figure 10
**Mainboard Bottom
Connectors**

1. ODD Connector
2. HDD Connector
3. LCD Cable Connector
4. DC-In
5. CCD + MIC Connector

Chapter 2: Disassembly

Overview

This chapter provides step-by-step instructions for disassembling the **W670RCQ** series notebook's parts and subsystems. When it comes to reassembly, reverse the procedures (unless otherwise indicated).

We suggest you completely review any procedure before you take the computer apart.

Procedures such as upgrading/replacing the RAM, optical device and hard disk are included in the User's Manual but are repeated here for your convenience.

To make the disassembly process easier each section may have a box in the page margin. Information contained under the figure # will give a synopsis of the sequence of procedures involved in the disassembly procedure. A box with a  lists the relevant parts you will have after the disassembly process is complete. **Note:** The parts listed will be for the disassembly procedure listed ONLY, and not any previous disassembly step(s) required. Refer to the part list for the previous disassembly procedure. The amount of screws you should be left with will be listed here also.

A box with a  will also provide any possible helpful information. A box with a  contains warnings.

An example of these types of boxes are shown in the sidebar.

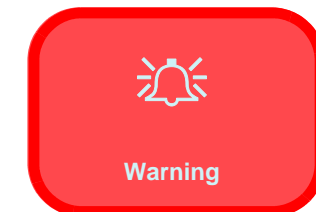
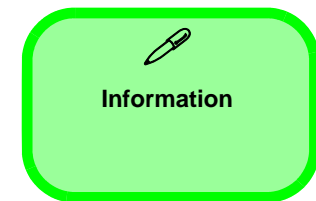

Disassembly

NOTE: All disassembly procedures assume that the system is turned **OFF**, and disconnected from any power supply (the battery is removed too).

Maintenance Tools

The following tools are recommended when working on the notebook PC:

- M3 Philips-head screwdriver
- M2.5 Philips-head screwdriver (magnetized)
- M2 Philips-head screwdriver
- Small flat-head screwdriver
- Pair of needle-nose pliers
- Anti-static wrist-strap

Connections

Connections within the computer are one of four types:

Locking collar sockets for ribbon connectors	To release these connectors, use a small flat-head screwdriver to gently pry the locking collar away from its base. When replacing the connection, make sure the connector is oriented in the same way. The pin1 side is usually not indicated.
Pressure sockets for multi-wire connectors	To release this connector type, grasp it at its head and gently rock it from side to side as you pull it out. Do not pull on the wires themselves. When replacing the connection, do not try to force it. The socket only fits one way.
Pressure sockets for ribbon connectors	To release these connectors, use a small pair of needle-nose pliers to gently lift the connector away from its socket. When replacing the connection, make sure the connector is oriented in the same way. The pin1 side is usually not indicated.
Board-to-board or multi-pin sockets	To separate the boards, gently rock them from side to side as you pull them apart. If the connection is very tight, use a small flat-head screwdriver - use just enough force to start.

Maintenance Precautions

The following precautions are a reminder. To avoid personal injury or damage to the computer while performing a removal and/or replacement job, take the following precautions:

1. **Don't drop it.** Perform your repairs and/or upgrades on a stable surface. If the computer falls, the case and other components could be damaged.
2. **Don't overheat it.** Note the proximity of any heating elements. Keep the computer out of direct sunlight.
3. **Avoid interference.** Note the proximity of any high capacity transformers, electric motors, and other strong magnetic fields. These can hinder proper performance and damage components and/or data. You should also monitor the position of magnetized tools (i.e. screwdrivers).
4. **Keep it dry.** This is an electrical appliance. If water or any other liquid gets into it, the computer could be badly damaged.
5. **Be careful with power.** Avoid accidental shocks, discharges or explosions.
 - Before removing or servicing any part from the computer, turn the computer off and detach any power supplies.
 - When you want to unplug the power cord or any cable/wire, be sure to disconnect it by the plug head. Do not pull on the wire.
6. **Peripherals** – Turn off and detach any peripherals.
7. **Beware of static discharge.** ICs, such as the CPU and main support chips, are vulnerable to static electricity. Before handling any part in the computer, discharge any static electricity inside the computer. When handling a printed circuit board, do not use gloves or other materials which allow static electricity buildup. We suggest that you use an anti-static wrist strap instead.
8. **Beware of corrosion.** As you perform your job, avoid touching any connector leads. Even the cleanest hands produce oils which can attract corrosive elements.
9. **Keep your work environment clean.** Tobacco smoke, dust or other air-borne particulate matter is often attracted to charged surfaces, reducing performance.
10. **Keep track of the components.** When removing or replacing any part, be careful not to leave small parts, such as screws, loose inside the computer.

Cleaning

Do not apply cleaner directly to the computer, use a soft clean cloth.

Do not use volatile (petroleum distillates) or abrasive cleaners on any part of the computer.



Power Safety Warning

Before you undertake any upgrade procedures, make sure that you have turned off the power, and disconnected all peripherals and cables (including telephone lines and power cord). It is advisable to also remove your battery in order to prevent accidentally turning the machine on.

Disassembly Steps

The following table lists the disassembly steps, and on which page to find the related information. **PLEASE PERFORM THE DISASSEMBLY STEPS IN THE ORDER INDICATED.**

To remove the Battery:

1. Remove the battery *page 2 - 5*

To remove the Keyboard:

1. Remove the battery *page 2 - 5*
2. Remove the keyboard *page 2 - 6*

To remove the HDD:

1. Remove the battery *page 2 - 5*
2. Remove the HDD *page 2 - 7*

To remove the Optical Device:

1. Remove the battery *page 2 - 5*
2. Remove the Optical device *page 2 - 10*

To remove the System Memory:

1. Remove the battery *page 2 - 5*
2. Remove the system memory *page 2 - 12*

To remove the Wireless LAN Module:

1. Remove the battery *page 2 - 5*
2. Remove the WLAN *page 2 - 14*

To remove the SSD Module:

1. Remove the battery *page 2 - 5*
2. Remove the SSD module *page 2 - 16*

To remove the CCD Module:

1. Remove the battery *page 2 - 5*
2. Remove the CCD module *page 2 - 17*

Removing the Battery

1. Turn the computer **off**, and turn it over.
2. Slide the latch **1** in the direction of the arrow (*Figure 1a*).
3. Slide the latch **2** in the direction of the arrow, and hold it in place (*Figure 1a*).
4. Slide the battery **3** in the direction of the arrow **4** (*Figure 1b*).

Figure 1
Battery Removal

- a. Slide the latch and hold it in place.
- b. Slide the battery in the direction of the arrow.

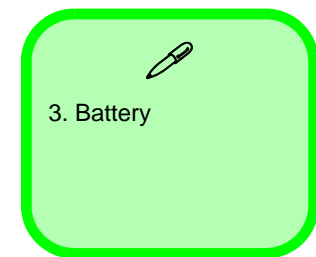
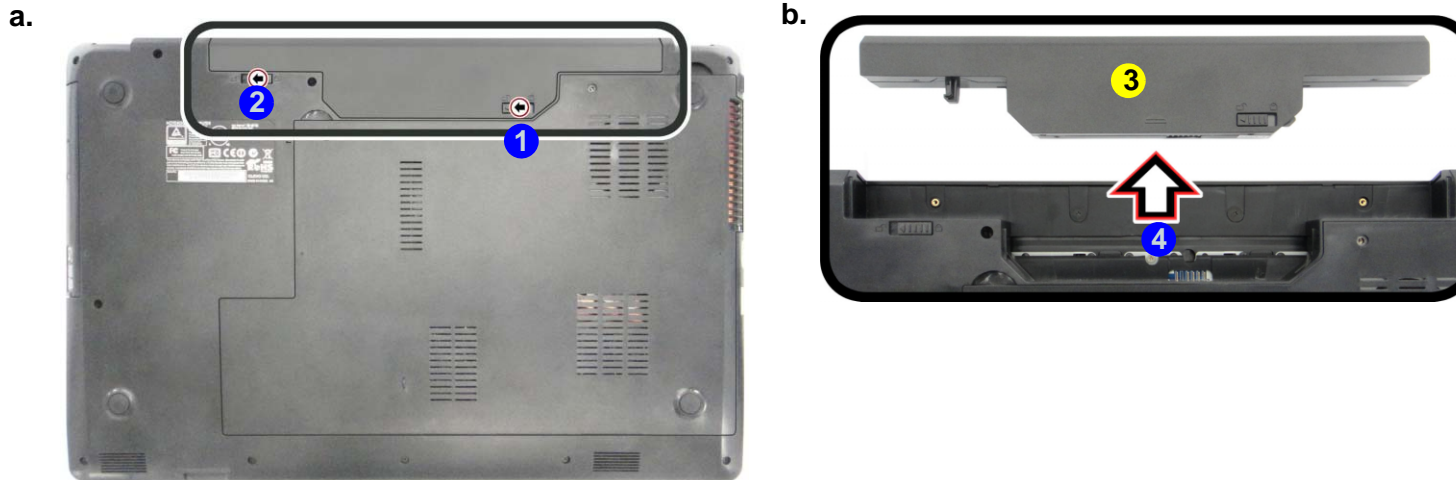

Disassembly

Figure 2

Keyboard Removal

- Remove screw and press at point 2 to un-snap the center cover module.
- Remove the center cover module.
- Remove the screws.
- Carefully lift the keyboard up and disconnect the ribbon cables from its locking collar.
- Remove the keyboard.

Removing the Keyboard

- Turn off the computer, turn it over, remove the battery (page 2 - 5).
- Remove screw 1 and carefully press at point 2, from the bottom of the computer to un-snap the center cover module (use the eject pin tool to do this - Figure 2a)
- Turn the computer over, remove the un-snap center cover module 3 from the computer (Figure 2b).
- Remove screws 4 - 8 from the keyboard (Figure 2c).
- Lift the keyboard up, being careful not to bend the keyboard ribbon cable 9. Disconnect the keyboard ribbon cable from the locking collar socket 10 and the keyboard LED cable 11 from its locking collar 12 (Figure 2d).
- Carefully lift the keyboard 13 off the computer (Figure 2e).

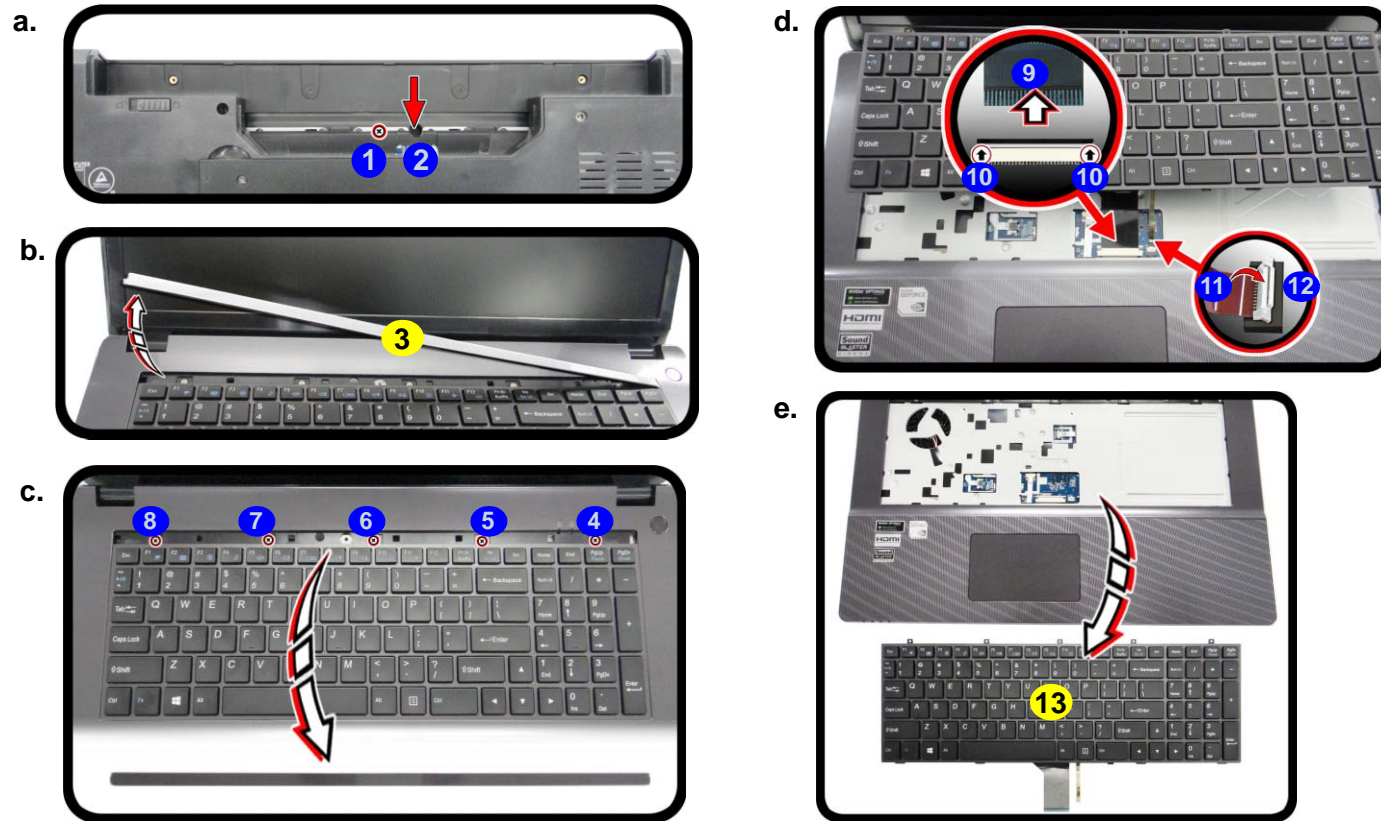



3. Center Cover Module
13. Keyboard

- 6 Screws

Removing the Hard Disk Drive

The hard disk drive can be taken out to accommodate other 2.5" serial (SATA) hard disk drives with a height of 9.5mm or 7mm (h). Follow your operating system's installation instructions, and install all necessary drivers and utilities (as outlined in **Chapter 4 of the User's Manual**) when setting up a new hard disk.

Hard Disk Upgrade Process

1. Turn **off** the computer, and remove the battery ([page 2 - 5](#)).
2. Locate the component bay cover and remove screws **1** - **2** ([Figure 3a](#)).
3. Lift the component bay cover **3** off the computer case by applying pressure at points **4** & **5**; if you have problems using a finger to do this, then use a non-abrasive, non-sharp object (e.g. a coin) to lift the cover up before removal).

Figure 3
HDD Assembly Removal

- a. Remove the screws. Lift the component bay cover off the computer.

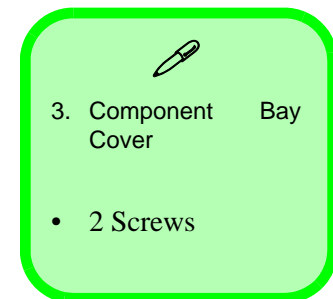
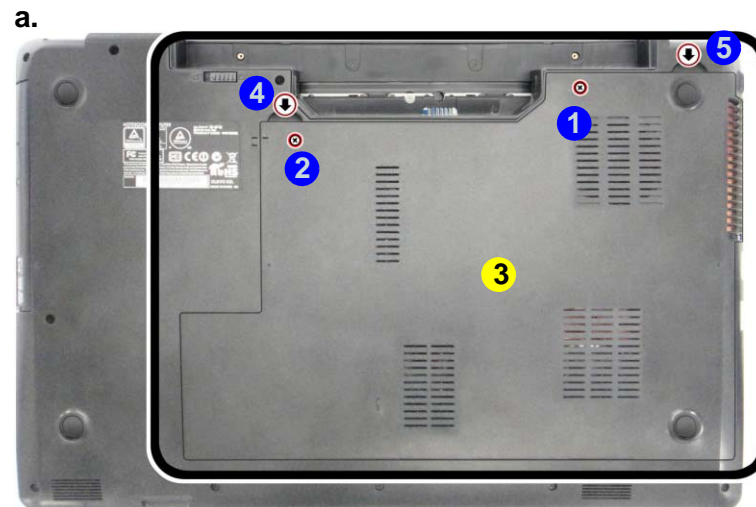



Disassembly

Figure 4
**HDD Assembly
 Removal (cont'd.)**

- c. Remove the bay cover.
 d. Lift the rubber and slide the HDD assembly in the direction of the arrow to lift the HDD assembly out.
 e. Remove the screws and adhesive cover.

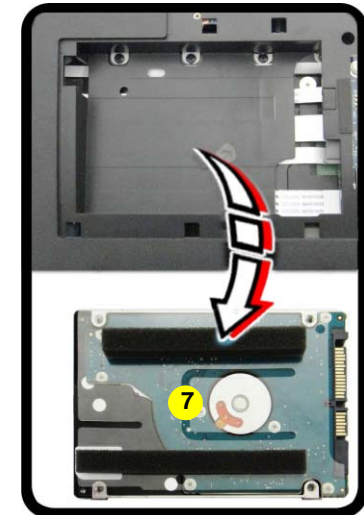
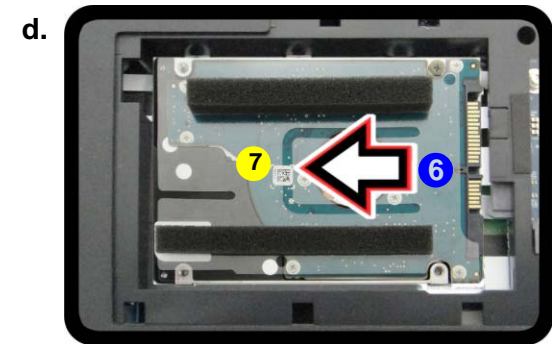
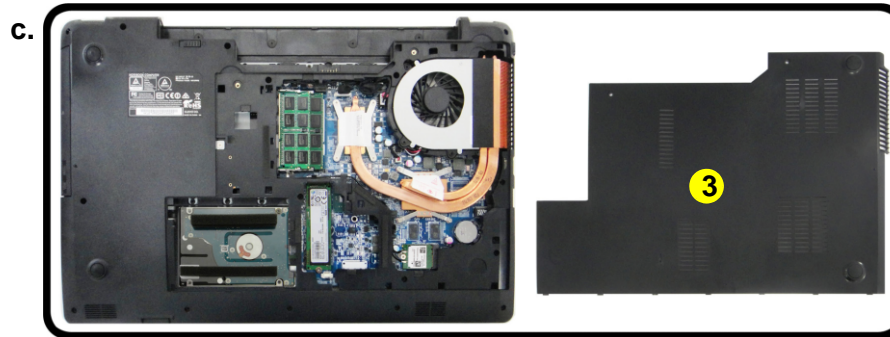
4. Remove the component bay cover **3** (*Figure 4c*).
 5. Grip the tab to slide the hard disk assembly in the direction of arrow **6** to lift the hard disk assembly **7** out (*Figure 4d*).
 6. Remove the screws **8** - **9** and the adhesive cover **10** from the hard disk **11** (*Figure 4e*).
 7. Reverse the process to install a new hard disk (do not forget to replace the screws and bay cover).





HDD System Warning

New HDD's are blank. Before you begin make sure:

You have backed up any data you want to keep from your old HDD.

You have all the CD-ROMs and FDDs required to install your operating system and programs.

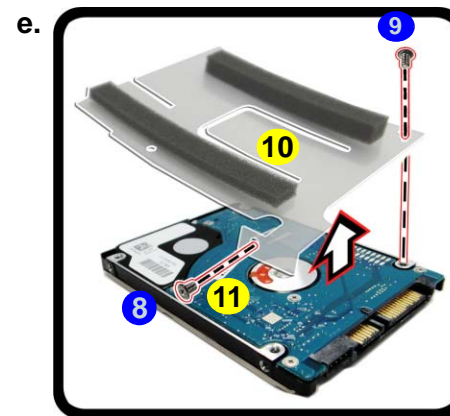
If you have access to the internet, download the latest application and hardware driver updates for the operating system you plan to install. Copy these to a removable medium.



- 
3. Component Bay Cover
 7. HDD Assembly
 10. Adhesive Cover
 11. HDD
- 2 Screws

Hard Disk Size Note (Foam Rubber Insert)

Note that the hard disks pictured on the following pages are all 9.5mm(H) hard disk drives. In some cases 7mm(H) hard disk drives will be installed. For more information contact your distributor/supplier, and bear in mind your warranty terms.

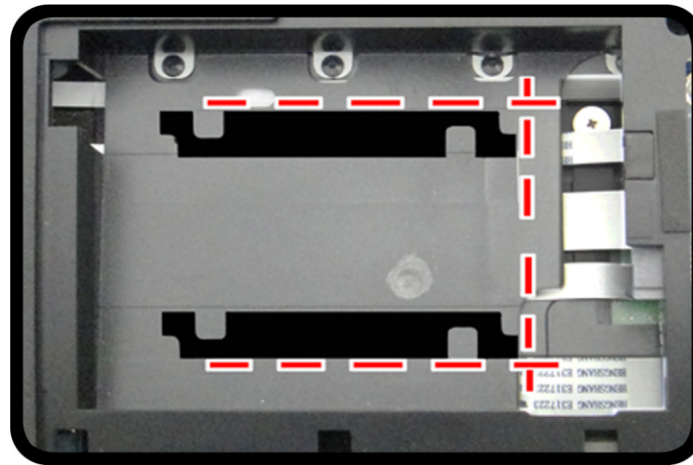

Figure 5
**Foam Rubber
Insert for 7mm(H)
HDDs**

- If you are replacing a 9.5mm(H) HDD with a 7mm(H) HDD then insert the foam rubber insert (as shown above).
- If you are replacing a 7mm(H) HDD with a 9.5mm(H) HDD then remove the foam rubber insert.

Disassembly

Figure 6
**Optical Device
 Removal**

- Remove the screws. Lift the component bay cover off the computer.
- Remove the screw at point 6.
- Use a screwdriver to carefully push out the optical device at point 7.

Removing the Optical (CD/DVD) Device

- Turn **off** the computer, and remove the battery ([page 2 - 5](#)).
- Locate the component bay cover and remove screws 1 - 2 ([Figure 6a](#)).
- Lift the component bay cover 3 off the computer case by applying pressure at points 4 & 5; if you have problems using a finger to do this, then use a non-abrasive, non-sharp object (e.g. a coin) to lift the cover up before removal).
- Remove the screw at point 6 ([Figure 6b](#)).
- Use a screwdriver to carefully push out the optical device 8 at point 7 ([Figure 6c](#)).

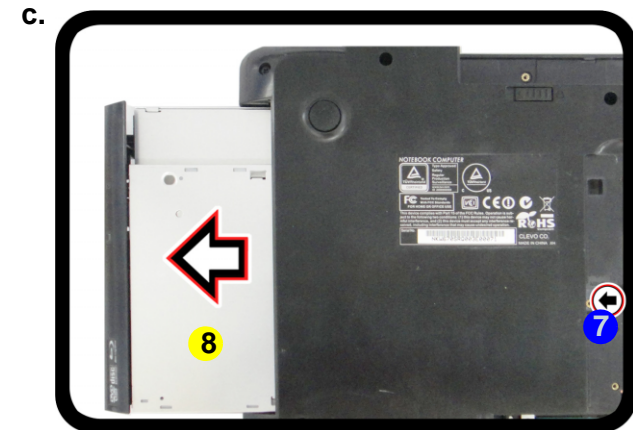
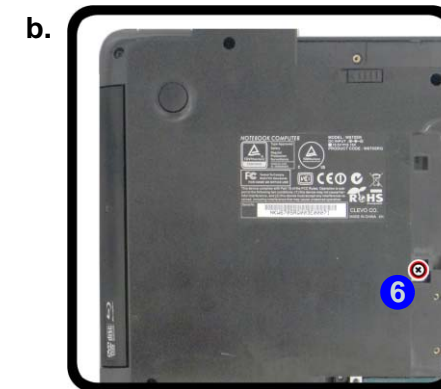
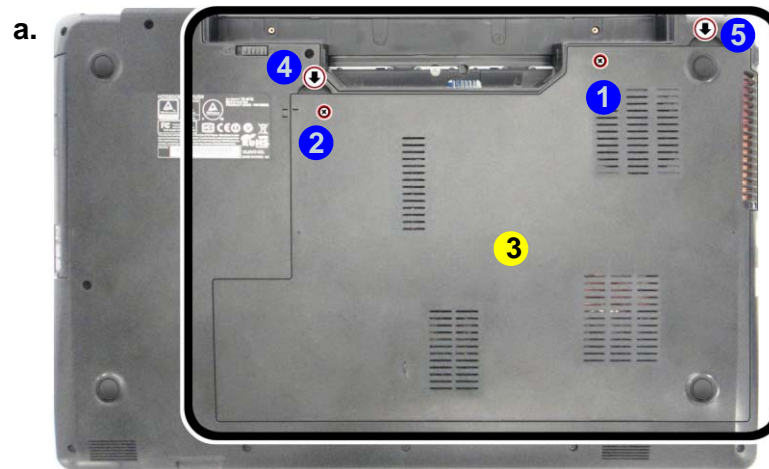

- 3. Component Bay Cover
- 8. Optical Device

- 3 Screws

6. Carefully pry the bezel **10** off the optical device at point **9** (*Figure 7e*).
7. Separate the bezel **10** and the optical device.
8. Reverse the process to attach the front bezel **10** with the new optical device at point **11** (*Figure 7g*).
9. Insert the new device and carefully slide it into the computer (the device only fits one way. DO NOT FORCE IT; The screw holes should line up).
10. Reinsert the component bay cover by placing it on the bottom case assembly, and aligning the pins at the bottom of the cover with the slots in the case to ensure a proper fit. Press down on the cover to make sure it fits tightly.
11. Replace the screws and battery.
12. Restart the computer to allow it to automatically detect the new device.

Figure 7
**Optical Device
 Removal (cont'd.)**

- e. Pry the bezel off the optical device.
- f. Separate the bezel and optical device.
- g. Install the front bezel.
- h. Replace the component bay cover and screws.

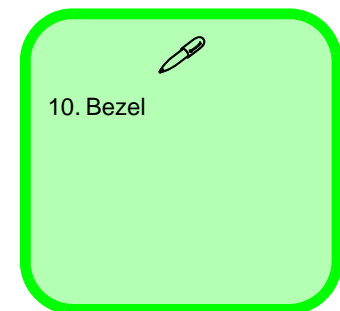
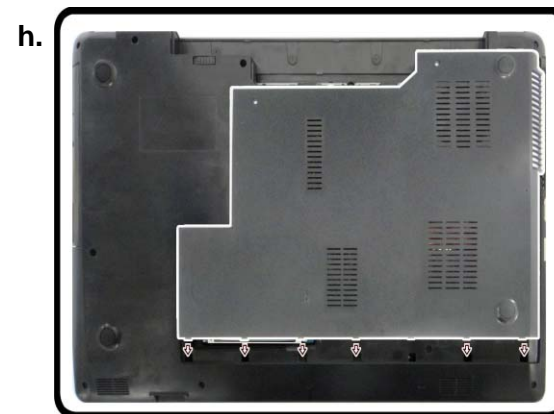

Disassembly

Figure 8
RAM Module Removal

- Remove the screws from the component bay cover.
- Remove the component bay cover. The RAM modules will be visible at point **6** on the mainboard.



Contact Warning

Be careful not to touch the metal pins on the module's connecting edge. Even the cleanest hands have oils which can attract particles, and degrade the module's performance.



3. Component Bay Cover

- 2 Screws

Removing the System Memory (RAM)

The computer has two memory sockets for 204 pin Small Outline Dual In-line Memory Modules (SO-DIMM) supporting DDR3L up to 1600 MHz. The main memory can be expanded up to 16GB. The total memory size is automatically detected by the POST routine once you turn on your computer.

Memory Upgrade Process

- Turn **off** the computer, turn it over, and remove the battery ([page 2 - 5](#)).
- Remove screws **1** - **2** from the component bay cover ([Figure 8a](#)).
- Lift the component bay cover **3** off the computer case by applying pressure at points **4** & **5**; if you have problems using a finger to do this, then use a non-abrasive, non-sharp object (e.g. a coin) to lift the cover up before removal).
- The RAM modules will be visible at point **6** on the mainboard ([Figure 8b](#)).

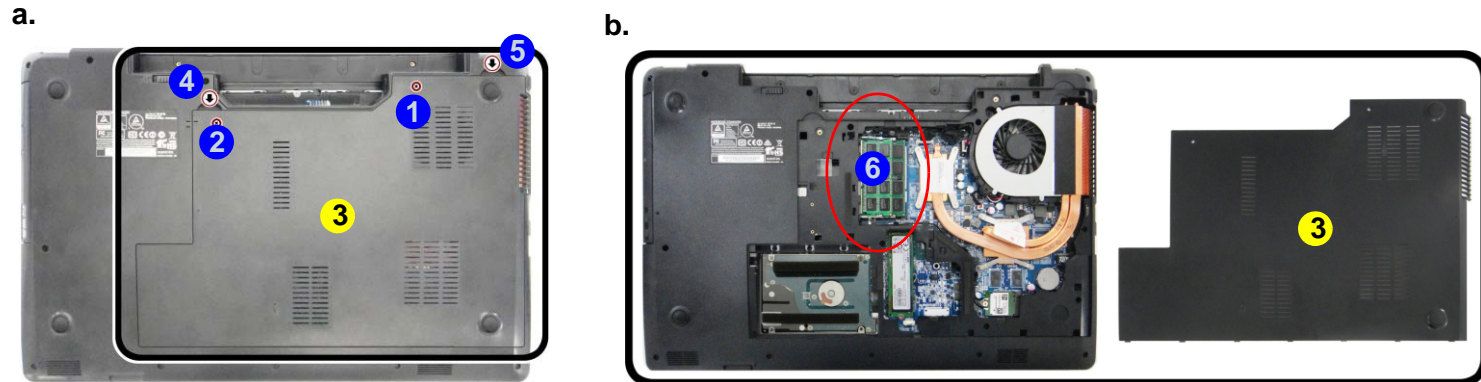

- Gently pull the two release latches (7 & 8) on the sides of the memory socket in the direction indicated by the arrows (Figure 9c).
- The RAM module 9 will pop-up (Figure 9d), and you can then remove it.
- Pull the latches to release the second module if necessary.
- Insert a new module holding it at about a 30° angle and fit the connectors firmly into the memory slot.
- The module will only fit one way as defined by its pin alignment. Make sure the module is seated as far into the slot as it will go. DO NOT FORCE IT; it should fit without much pressure.
- Press the module in and down towards the mainboard until the slot levers click into place to secure the module.
- Replace the component bay cover and the screws (see page 2 - 12).
- Restart the computer to allow the BIOS to register the new memory configuration as it starts up.

Figure 9
RAM Module
Removal (cont'd)

- Pull the release latches.
- Remove the module.





Single Memory Module Installation

If your computer has a single memory module, then insert the module into the **Channel 0 (JDIMM1)** socket. In this case this is the **lower memory socket** (the socket closest to the mainboard).



Contact Warning

Be careful not to touch the metal pins on the module's connecting edge. Even the cleanest hands have oils which can attract particles, and degrade the module's performance.



9. RAM Module

Disassembly

Figure 10
**Wireless LAN
Module Removal**

- Locate the WLAN.
- Disconnect the cables **2** and **3**, and remove the screw **4**.
- The WLAN module will pop up.

Note: Make sure you reconnect the antenna cable to the “1 + 2” socket (*Figure 10b*).

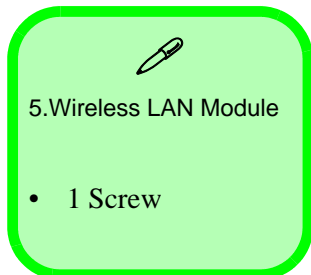

Removing the Wireless LAN Module

- Turn **off** the computer, turn it over, remove the battery (*page 2 - 5*) and the component bay cover (*page 2 - 7*).
- The Wireless LAN module will be visible at point **1** on the mainboard (*Figure 10a*).
- Carefully disconnect the cables **2** & **3**, and then remove the screw **4** (*Figure 10b*).
- The Wireless LAN module **5** (*Figure 10c*) will pop-up, and you can remove it from the computer.

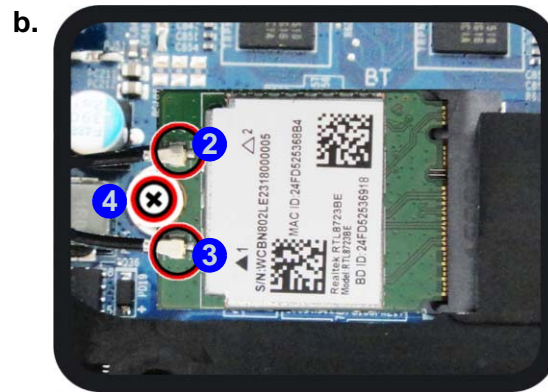
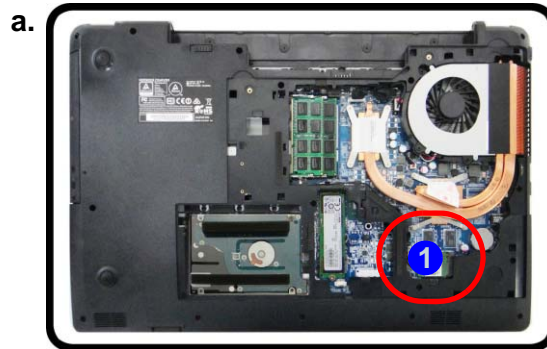

Wireless LAN, Combo, 3G & LTE Module Cables

Note that the cables for connecting to the antennae on WLAN, WLAN & Bluetooth Combo, 3G and LTE modules are not labelled. The cables/covers (each cable will have either a black or transparent cable cover) are color coded for identification as outlined in the table below.

Module Type	Antenna Type	Cable Color	Cable Cover Type
WLAN/WLAN & Bluetooth Combo	WM 1	Black	Transparent
	WM 2	Gray	
	WM 3	White	
LTE Broadband	LTE 1	Black	Black
	LTE 2	Gray	
3G Broadband	3G 1	Black	Black
	3G 2	Gray	

Cable 1 is usually connected to antenna 1 (Main) on the module, and cable 2 to antenna 2 (Aux).

Disassembly

Figure 11
SSD Module Removal

Removing the SSD Module

1. Turn off the computer, remove the battery ([page 2 - 5](#)), and component bay cover ([page 2 - 7](#)).
 2. Locate the module, it is visible at point **1** ([Figure 11a](#)).
 3. Carefully remove the screw **2** from the module ([Figure 11b](#)).
 4. The module **3** will pop-up ([Figure 11c](#)).
 5. Lift the module **3** up and off the computer ([Figure 11c](#)).
- a. Locate the module.
b. Remove the screw.
c. The module will pop-up.
d. Lift the module up off the socket.

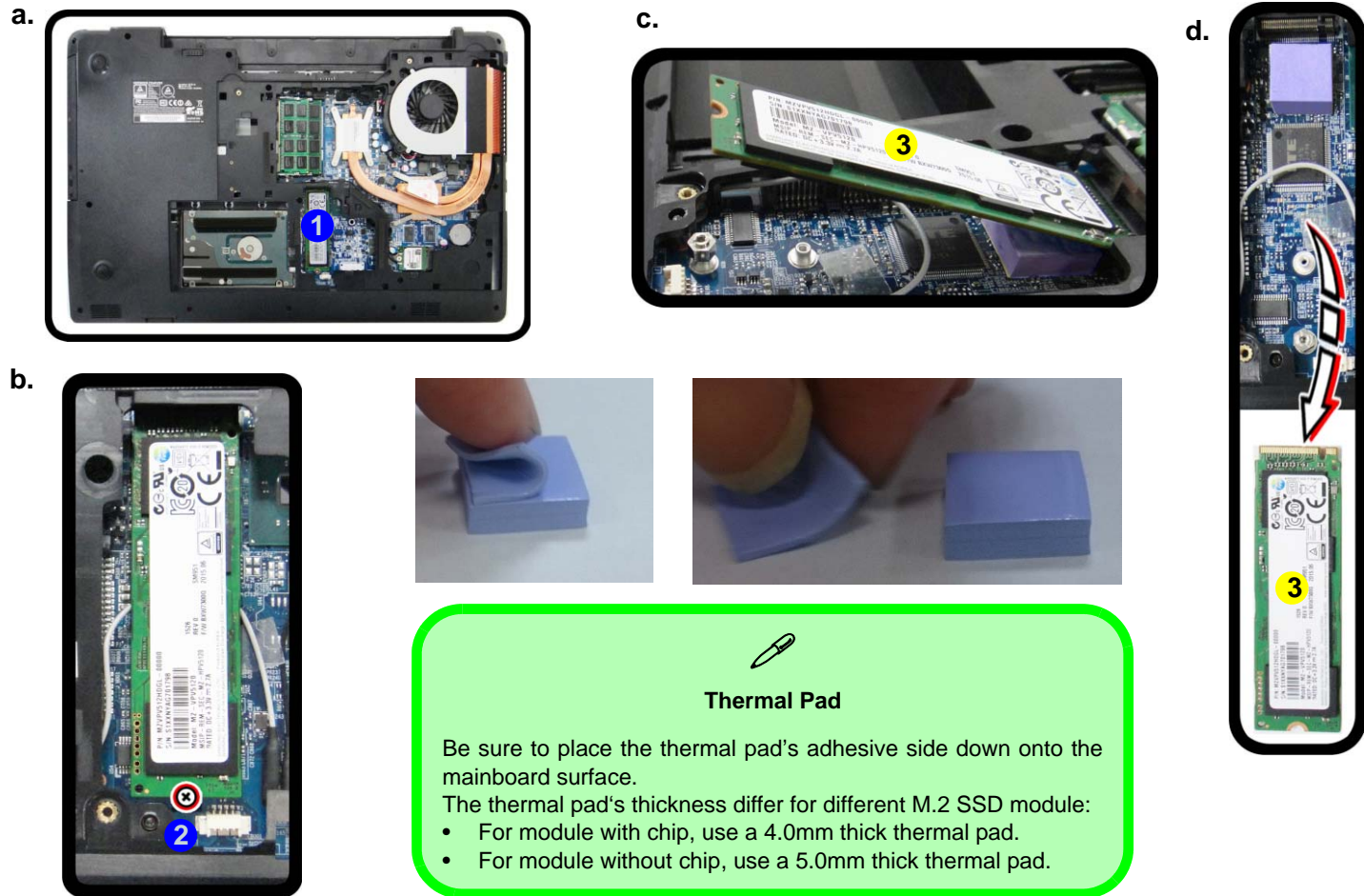

Removing the CCD

1. Turn **off** the computer, turn it over, and remove the battery ([page 2 - 5](#)).
2. Run your fingers around the inner frame of the LCD panel at the points as indicated by the arrows **1** - **4**.
3. Lay the computer down on a flat surface with the top case up forming a 90 degree angle. Push the LCD front cover **5** upwards before carefully lifting it up ([Figure 12b](#)).
4. Remove the LCD front cover **5** ([Figure 12c](#)).

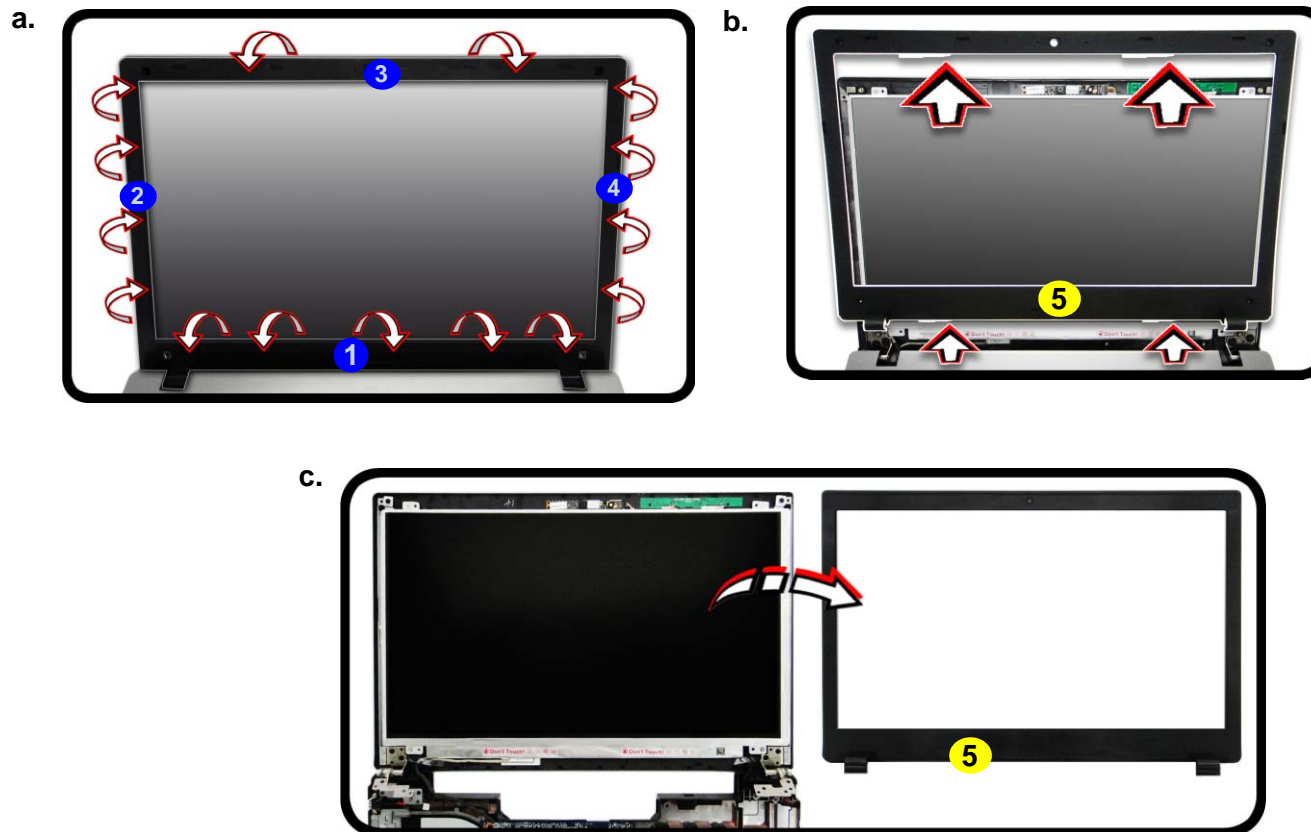

Figure 12
CCD Removal

- a. Run your fingers around the inner frame of the LCD panel at the points indicated by the arrows.
- b. Lay the computer down on a flat surface with the top case up forming a 90 degree angle. Push the LCD front panel upwards before carefully lifting it up.
- c. Remove the LCD front cover.



Disassembly

Figure 13
CCD Removal
(cont'd)

- d. Disconnect the cable.
- e. Remove the CCD module.

- 5. Disconnect the cable **6** (*Figure 13d*).
- 6. Remove the CCD module **7** (*Figure 13e*).
- 7. Reverse the process to install a new CCD module.

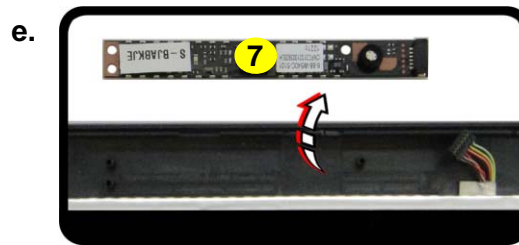

7. CCD Module

Appendix A:Part Lists

This appendix breaks down the *W670RCQ* series notebook's construction into a series of illustrations. The component part numbers are indicated in the tables opposite the drawings.

Note: This section indicates the *manufacturer's* part numbers. Your organization may use a different system, so be sure to cross-check any relevant documentation.

Note: Some assemblies may have parts in common (especially screws). However, the part lists DO NOT indicate the total number of duplicated parts used.

Note: Be sure to check any update notices. The parts shown in these illustrations are appropriate for the system at the time of publication. Over the product life, some parts may be improved or re-configured, resulting in *new* part numbers.

Part List Illustration Location

The following table indicates where to find the appropriate part list illustration.

Table A - 1
**Part List Illustration
Location**

Part	
Top	<i>page A - 3</i>
Bottom	<i>page A - 4</i>
DVD Dual Drive	<i>page A - 5</i>
HDD	<i>page A - 6</i>
2nd HDD	<i>page A - 7</i>
LCD	<i>page A - 8</i>

Top

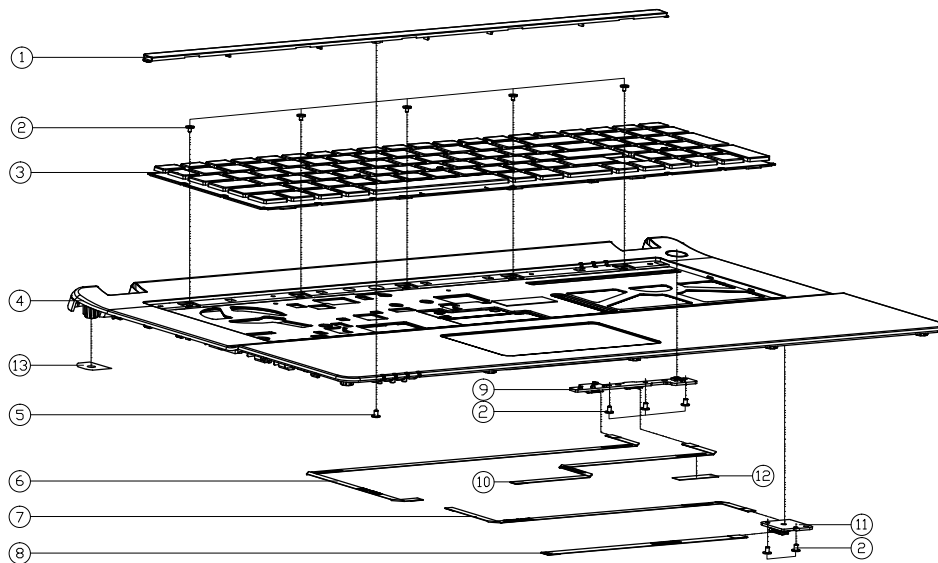
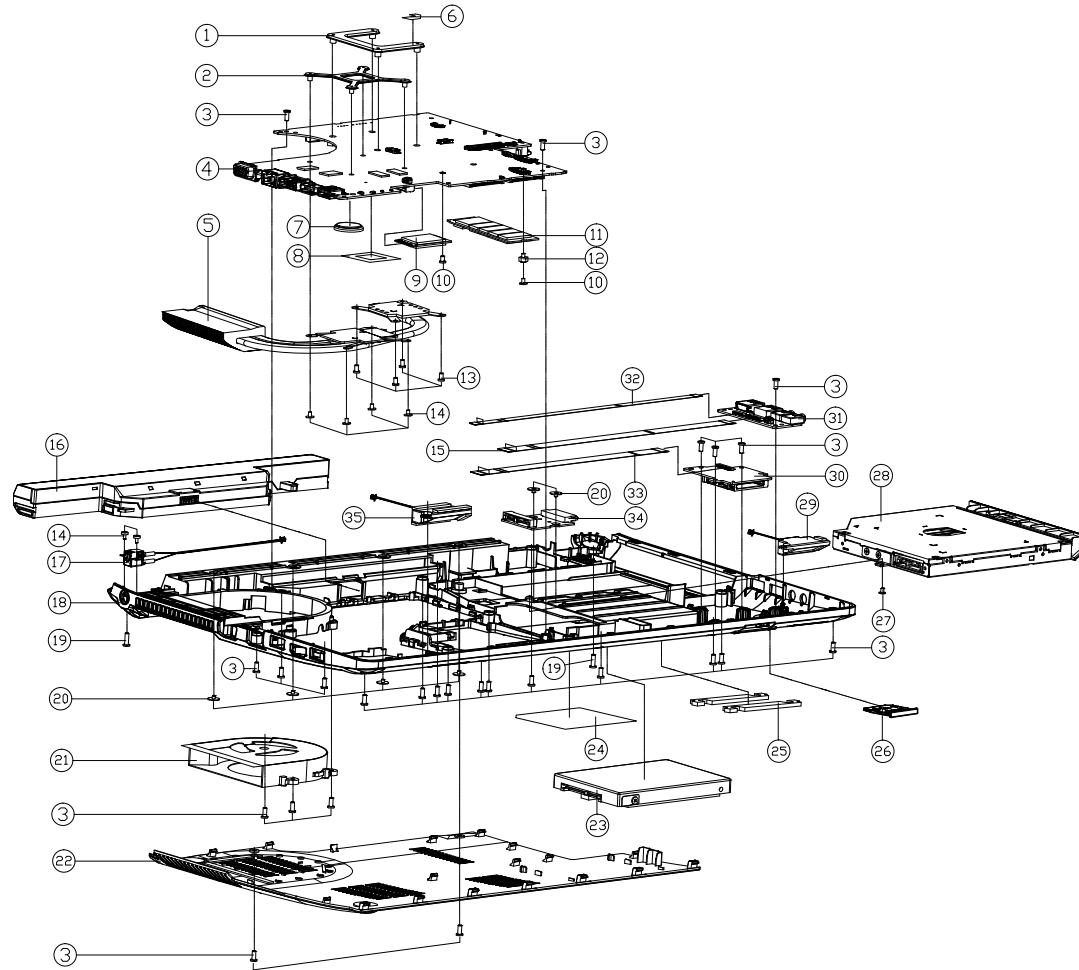

Figure A - 1
Top

ITEM	PART NAME	PART NO	REMARK
1	KB COVER TN37 15BX W670SRQ	6-42-W6702-042	
2	SCREW M2x3L KI NI ICT NY (DD=04.5,DT=0.4)	6-35-B1120-3RE	
3	WIN8 K/B USA(BLACK& FRAME)US) MODULE W670SRQ	6-79-W670SRQK-010-W	
3	WIN8 K/B US-INTERNATIONAL (BLACK& FRAME)US) MODULE W670SRQ	6-79-W670SBQK-010-W	
4	IDLE 24H-TOP CASE MODULE ASS'Y W670RCQ	6-79-W670RCQ2-010	
4	IDLE 24H-TOP CASE MODULE FOR LIGHT KB ASS'Y W670RCQ	6-79-W670RCQ2-020	
4	IDLE 24H-TOP CASE MODULE ASS'Y W670SCQ1	6-79-W670SCQ2-010-1	
4	IDLE 24H-TOP CASE MODULE FOR LIGHT KB ASS'Y W670SCQ1	6-79-W670SCQ2-020-1	
5	SCREW M2x2.5L KI BK/Z ICT NY #3.5 T=0.3	6-35-B6120-2RB	
6	FFC CABLE FOR MB TO POWER BOARD 4PIN W670SRQCNJSD	6-43-W6700-060	
7	FFC CABLE FOR MB TO CLICK BOARD 6PIN W670RCQDHTD	6-43-W67C0-010-1	
8	FFC CABLE FOR CLICK PAD TO CLICK BOARD 6PIN W670SRQCNJSD	6-43-W6700-050	
9	POWER SWITCH BOARD V1.0 W670RCQ	6-77-W67CS-D01	
10	FFC CABLE FOR MB TO POWER BOARD 4PIN W670SRQCNJSD	6-43-W6700-070	
11	EXT CLICK BOARD V1.0 W670RCQ	6-77-W67C2-D01	
12	TAPE MYLAR (C),MYLAR M550J	6-40-M55J2-030	
13	HINGE L GASKET(9.5*7.3*0.2) FOR W670SRQ	6-47-00190-950	

Bottom

Figure A - 2
Bottom



ITEM	PART NAME	PART NO	REMARK
1	CPU SUPPORT BRACKET SECC T=1.5 P150MM	6-33-X510S-011	
2	VGA SUPPORTER SUS430 W650SH	6-33-W650S-010-1	
3	SCREW M2.5*6L K BZ ICT NY	6-35-B2125-6RA	
4	HEAT SINK MODULE W650RB	6-31-W65R3-100	
5	GASKET (22*135*0.15) FOR MB W650SR	6-47-00190-220	
6	BATTERY 3V 220MA BBRCR2032B (KTS)	6-23-6A282-030	
7	VGA CHIP M/LAKE 30KSD N89P-GE2 M660TU (R000)	6-40-M860S-091	FOR W67XRCD
8	CPU M/LAKE CONDUCTIVE PASTE FOR W650SR	6-40-W650S-020	FOR W67XRBD
9	WARRANTY LABEL FOR W650SR	6-88-W95LF-4200	(OPTION)
9	WARRANTY LABEL FOR W650SR	6-88-W95LF-4240	(OPTION)
9	WARRANTY LABEL FOR W650SR	6-88-N240F-4200	(OPTION)
9	WARRANTY LABEL FOR W650SR	6-88-S210F-9400	(OPTION)
9	WARRANTY LABEL FOR W650SR	6-88-N170F-5100	(OPTION)
9	WARRANTY LABEL FOR W650SR	6-88-N25JF-4200	(OPTION)
10	SCREW M2*5L KI NI ICT NY (OD=0.5, T=0.5)	6-35-B1120-2R0	
11	SSD M2 2280 SATA CRUCIAL CT500BX4080 QVOSSD SATA MLC	6-85-DS15B-S00	(OPTION)
11	SSD M2 2280 SATA CRUCIAL CT500BX4080 QVOSSD SATA MLC	6-85-DS15A-100	(OPTION)
11	SSD M2 2280 SATA INTEL S5500X4080 QVOSSD SATA MLC	6-85-DS13G-Z00	(OPTION)
11	SSD M2 2280 SATA SAMSUNG MZVL2280BW QVOSSD SATA MLC	6-85-DS1R6-S01	(OPTION)
12	SCREW M2*5L KI NI ICT NY (OD=0.5, T=0.5)	6-35-ZA120-2R5	
13	SCREW M2*5L KI NI ICT NY (OD=0.5, T=0.5)	6-35-B1120-4RE	
14	SCREW M2*6*3.5L KIT=12 D=4.5 BZ ICT NY	6-35-B2116-3R5	
15	PC CABLE FOR M2 TO SATA DRIVE (OPTIONAL)	6-43-W6700-020	
16	WARRANTY LABEL FOR W650SR	6-87-W650S-4D7A4	(OPTION)
16	WARRANTY LABEL FOR W650SR	6-87-W650S-4D4A4	(OPTION)
16	WARRANTY LABEL FOR W650SR	6-87-W650S-4D4A3	(OPTION)
16	WARRANTY LABEL FOR W650SR	6-87-W650S-4D7A3	(OPTION)
17	PC CABLE FOR JACK PLATE (OPTIONAL)	6-43-W65R0-030	
18	BOTTOM CASE MODULE W670RCD	6-39-W67C3-010	
19	SCREW M2.5*8L KI BK/Z NY ICT	6-35-B6125-8R0	
20	SCREW M2*5L KI BK/Z ICT NY (T=0.6)	6-35-B6120-2RE	
21	FAN/COOLING MODULE W670SR	6-23-AV15E-011	
22	CPU COVER MODULE W670SR	6-42-W670R-103	
23	W/D 2ND HDD ASSY W670SR	6-79-W670SRJ-030	
23	W/D 2ND HDD ASSY W670SR	6-79-W670SRJ-040	
23	W/D HDD ASSY W670SR	6-79-W670SRJ-010	
23	W/D HDD ASSY W670SR	6-79-W670SRJ-020	
24	PRODUCT LABEL FOR W670RCD	6-45-W670RCD3-010	
24	PRODUCT LABEL FOR W670RBD	6-45-W670RBD3-010	
25	SPONGE (OPTIONAL) FOR W670RCD	6-47-0019A-763	
26	WARRANTY LABEL FOR W650SR	6-42-W970R-020	
27	SCREW M2*5L KI NI ICT NY (OD=0.5, T=0.5)	6-35-B1120-3RE	
28	W/D HDD ASSY W670SCQ	6-79-W670SCQ-000	(OPTION)
28	SATA DVD SUPER MULTI ASSY (OPTION)	6-79-W670SCQ-001	(OPTION)
29	SPK/CABLE R 50MM (OPTIONAL) 2W 4T W670CD	6-23-5W67C-0R1	
30	CARD READER BOARD PCIE V3.0 W670SR	6-77-W670V-D13	
31	AUDIO BOARD V1.0A W650RC	6-77-W65R8-D01A	
32	PC CABLE FOR M2 TO SATA DRIVE (OPTIONAL)	6-43-W6700-010	
33	PC CABLE FOR M2 TO SATA DRIVE (OPTIONAL)	6-43-W6700-030	
34	EXT HDD BOARD V2.0 W670SR	6-77-W670N-D02	
35	SPK/CABLE L 40MM (OPTIONAL) 2W 4T W670CD	6-23-5W67C-0L1	

DVD DUAL

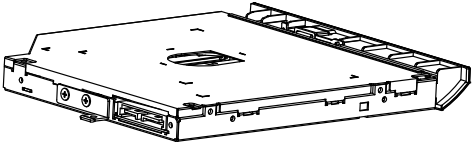
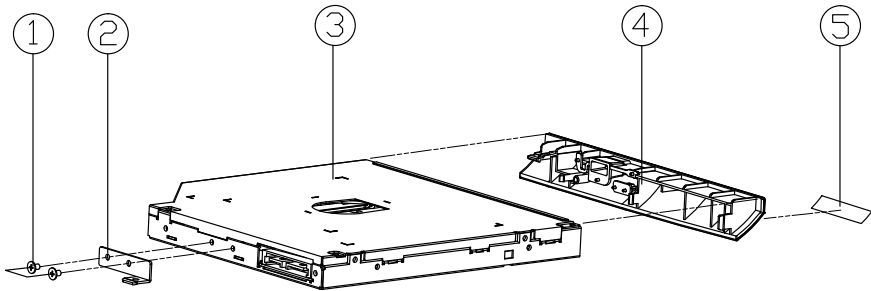

ITEM	PART NAME	PART NO	REMARK
1	《非附帶》SCREW M2X3L KI NI ICT GTY-PATCH	6-35-B1120-3RE	
2	DDD BRACKET SECC W860CU	6-33-W860Z-010	
3	DVD DVD SUPER MULTI 5 LPM DL 12MM BE-GARNDOK F/W LIDE W/O IN OVER 01 PLDS	6-85-A078X-L10	FOR PLDS
3	DVD DVD SUPER MULTI 5 LPM DL 12MM BE-GARNDOK F/W LIDE W/O IN OVER 01 TSST	6-85-A078X-T14	FOR TSST
4	DDD BEZEL MODULE W670SRQ	6-42-W670Z-101	
5	SUPER MULTI DDD BEZEL LABEL (SIZE CHANGE)	6-45-W860Q-012	

Figure A - 3
DVD DUAL

HDD

Figure A - 4
HDD

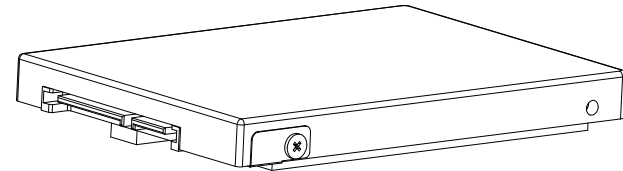
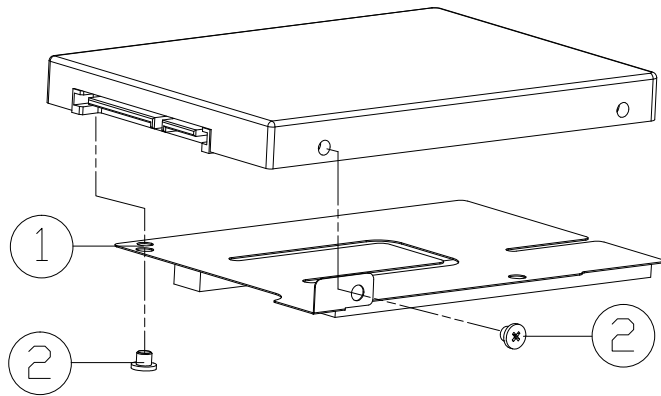

ITEM	PART NAME	PART NO	REMARK
1	HDD MYLAR PET+SPONG W670SRQ	6-40-W670J-011	
2	SCREW M3*2.5L KI NI ICT NY	6-35-B1130-2R5	

2nd HDD

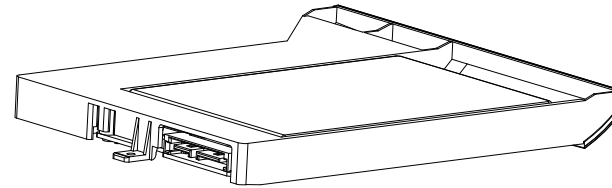
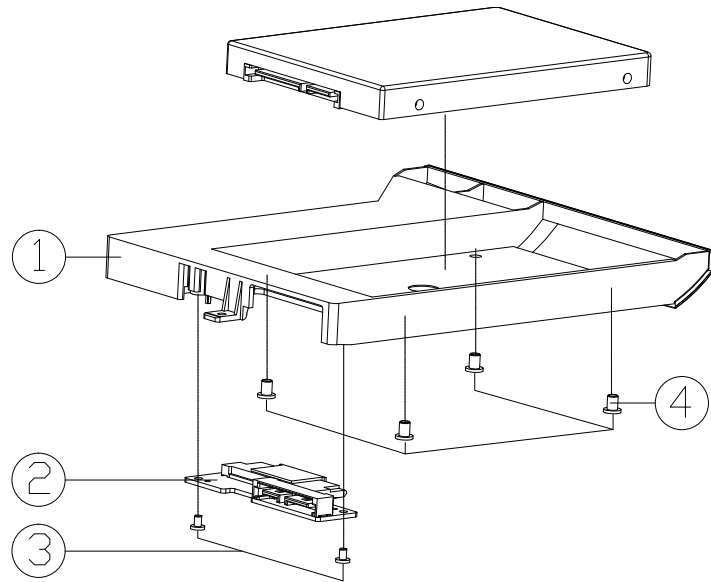
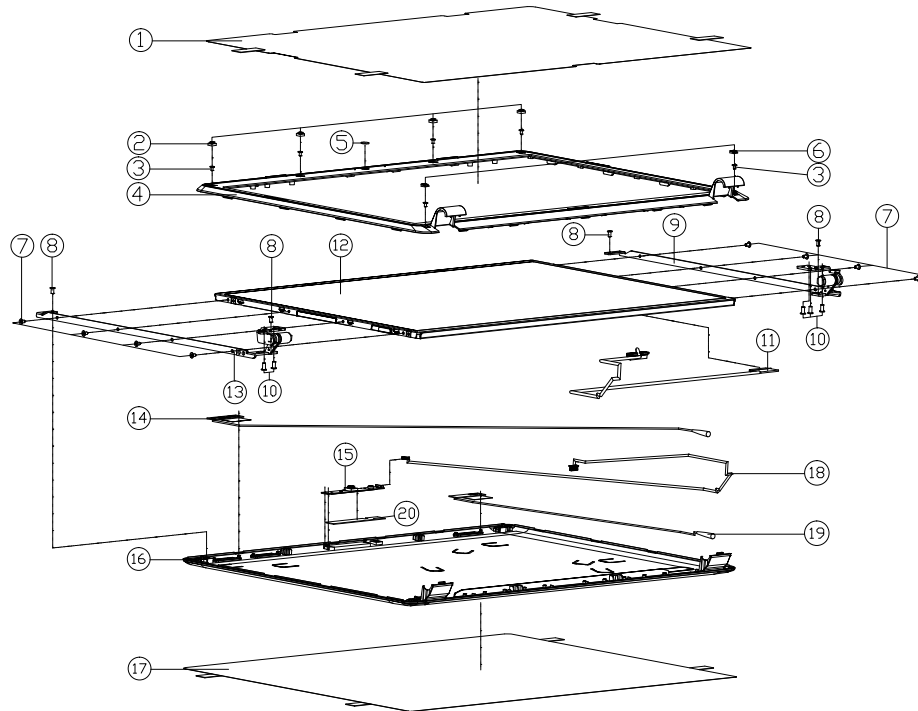

Figure A - 5
2nd HDD

ITEM	PART NAME	PART NO	REMARK
1	SECOND HDD HOUSING MODULE W670SRQ	6-42-W670J-101	
2	HDD TO HDD BOARD V4.0 W650SJ	6-77-W650N-D04	
3	SCREW M2*3L KI BK/Z ICT NY (Ø3.5 t=0.3)	6-35-B6120-3RE	
4	SCREW M3*4L KI BZ ICT NY (D=4.8 T=0.5)	6-35-B6130-4RB	

LCD

Figure A - 6
LCD



ITEM	PART NAME	PART NO	REMARK
1	LCD FRONT COVER PROTECTION MYLAR (MP) W670SRQ	6-40-W6701-011	
2	FRONT UP RUBBER (MP) FOR W670SRQ	6-47-W6701-022	
3	SCREW M2*SL K(KT=08 D=4.0) BK/Z ICT NY	6-35-B6120-5R0	
4	LCD FRONT COVER MIDDLE (D-MIC) FOR W670SRQ	6-39-W6701-013	
5	CCD LENS PMMA W650SR	6-42-W6501-010	
6	FRONT DOWN RUBBER (MP) FOR W670SRQ	6-47-W6701-032	
7	SCREW M2*SL KI NI ICT NY (DD=4.5,DT=0.4)	6-35-B1120-3RE	
8	SCREW M2.5*4L KI NI ICT NY	6-35-21125-4R0	
9	LCD HINGE R (MP) W670SRQ	6-33-W6701-0R1	
10	SCREW M2.5*6L K BZ ICT NY	6-35-82125-6RA	
11	WIRE CABLE FOR LVDS (QD) 40PIN (GLAC CONDUCTIVE) W670SRQ	6-43-W6701-011-L	FOR W670SXX (LVDS)
11	WIRE CABLE FOR TOP FOR EXP (P) (QD) 30 PIN (3P) (GLAC CONDUCTIVE) W670SRQ	6-43-W67J1-010-K	FOR W670SXX (EDP)
12	LCD 17.3" FHD CHIMET N173HGE-L11 (LED) 6.0 MM	6-50-NB260-D01	
12	LCD 17.3" HD+ CHIMET N173HGE-L23 (GLARE TYPE) (LED) 5.8MM	6-50-NA158-D04	
12	LCD 17.3" (HD+) INNOLOX CHIMET N173HGE-L33 (LED) 5.8MM	6-50-NA158-V00	
12	LCD 17.3" FHD (EDP) CHIMET N173HGE-E10(LED) 6.0 MM	6-50-NB260-D03	
12	LCD 17.3" HD+ LG LP173W01-TLH8 (LED) 6.0 MM	6-50-NA160-LOB	
12	LCD 17.3" HD+ EDP INNOLOX N173HGE-E13 (LED) 5.8MM	6-50-NA158-V01	
12	LCD 17.3" FHD (EDP) AU B173H1M011 (LED) 6.0 MM	6-50-NB260-G06	
13	LCD HINGE L (MP) W670SRQ	6-33-W6701-0L1	
14	ANTENNA PEK-4 WLAN COMBO V61 V61 PCB FR4 V41-700MM W670RC	6-23-7W67C-010	
15	WIRE CABLE FOR LVDS (QD) 40PIN (GLAC CONDUCTIVE) W670SRQ	6-43-W6701-011-L	FOR W670SXX (LVDS)
15	WIRE CABLE FOR TOP FOR EXP (P) (QD) 30 PIN (3P) (GLAC CONDUCTIVE) W670SRQ	6-43-W67J1-010-K	FOR W670SXX (EDP)
15	WIRE CABLE FOR LVDS (QD) 40PIN (GLAC CONDUCTIVE) W670SRQ	6-43-W6701-011-L	FOR W670SXX (LVDS)
15	WIRE CABLE FOR TOP FOR EXP (P) (QD) 30 PIN (3P) (GLAC CONDUCTIVE) W670SRQ	6-43-W67J1-010-K	FOR W670SXX (EDP)
16	LCD BACK COVER MIDDLE (CCD Rb Modify) FOR W670SRQ	6-39-W6701-023	FOR W670R80/RCC/RZC
16	LCD BACK COVER MIDDLE (MP) FOR W670SRQ(CHARGE)	6-39-W6701-122	FOR W670R201
17	LCD BACK COVER PROTECTION MYLAR (MP) W670SRQ	6-40-W6701-021	
18	WIRE CABLE FOR CCD+H-MIC 3.3V 8PIN 59MM (HD) W670SLQ	6-43-W67JT-010-2	
19	ANTENNA PEK-4 WLAN COMBO V61 V61 PCB FR4 V41-700MM W670RC	6-23-7W67C-020	
20	CCD GASKET (64.9*40*0.7) W670SRQ	6-47-00190-644	

Appendix B: Schematic Diagrams

This appendix has circuit diagrams of the *W670RCQ* notebook's PCB's. The following table indicates where to find the appropriate schematic diagram.

Diagram - Page	Diagram - Page	Diagram - Page
<i>System Block Diagram - Page B - 2</i>	<i>CRT - Page B - 20</i>	<i>5V, 5VS, 3.3V, 3.3VS, 3.3VA - Page B - 38</i>
<i>Processor 1/7 - Page B - 3</i>	<i>PCH 1/9 - Page B - 21</i>	<i>1.0V, VCCIO - Page B - 39</i>
<i>Processor 2/7 - Page B - 4</i>	<i>PCH 2/9 - Page B - 22</i>	<i>VDD3, VDD5 - Page B - 40</i>
<i>Processor 3/7 - Page B - 5</i>	<i>PCH 3/9 - Page B - 23</i>	<i>DDR3L 1.35V / 0.75VS - Page B - 41</i>
<i>Processor 4/7 - Page B - 6</i>	<i>PCH 4/9 - Page B - 24</i>	<i>POWER VCORE - Page B - 42</i>
<i>Processor 5/7 - Page B - 7</i>	<i>PCH 5/9 - Page B - 25</i>	<i>VCC_Core & VCCSA - Page B - 43</i>
<i>Processor 6/7 - Page B - 8</i>	<i>PCH 6/9 - Page B - 26</i>	<i>1.0DX_VCCSTG / VCCSFR_OC - Page B - 44</i>
<i>Processor 7/7 - Page B - 9</i>	<i>PCH 7/9 - Page B - 27</i>	<i>VCCGT - Page B - 45</i>
<i>DDR3 CHA SO-DIMM_0 - Page B - 10</i>	<i>PCH 8/9 - Page B - 28</i>	<i>VCCGT Output Stage - Page B - 46</i>
<i>DDR3 CHB SO-DIMM_0 - Page B - 11</i>	<i>PCH 9/9 - Page B - 29</i>	<i>AC_In, Charger - Page B - 47</i>
<i>PS8625 - Page B - 12</i>	<i>M.2 3G + M.2 SATA - Page B - 30</i>	<i>N16P/S, NVVDD, PEX, FBVDDQ - Page B - 48</i>
<i>PANEL, INVERTER - Page B - 13</i>	<i>M.2 WLAN+BT, PCIE4X SSD - Page B - 31</i>	<i>USB Charge, CCD, TPM, Power Conn - Page B - 49</i>
<i>VGA PCI-E Interface - Page B - 14</i>	<i>USB3.0, LED - Page B - 32</i>	<i>Audio Board - Page B - 50</i>
<i>VGA Frame Buffer Interface - Page B - 15</i>	<i>Card Reader (RTL8411B) - Page B - 33</i>	<i>Power Switch Board - Page B - 51</i>
<i>VGA Frame Buffer A - Page B - 16</i>	<i>HDD, TP, Audio, USB - Page B - 34</i>	<i>ODD to HDD Board - Page B - 52</i>
<i>VGA Frame Buffer C - Page B - 17</i>	<i>HDMI - Page B - 35</i>	
<i>VGA I/O - Page B - 18</i>	<i>AUDIO CODEC ALC269 VC2 - Page B - 36</i>	
<i>VGA NVVDD Decoupling - Page B - 19</i>	<i>KBC-ITE IT8587 - Page B - 37</i>	

Table B - 1
**SCHEMATIC
DIAGRAMS**



Version Note

The schematic diagrams in this chapter are based upon version 6-7P-W65R4-003. If your mainboard (or other boards) are a later version, please check with the Service Center for updated diagrams (if required).

System Block Diagram

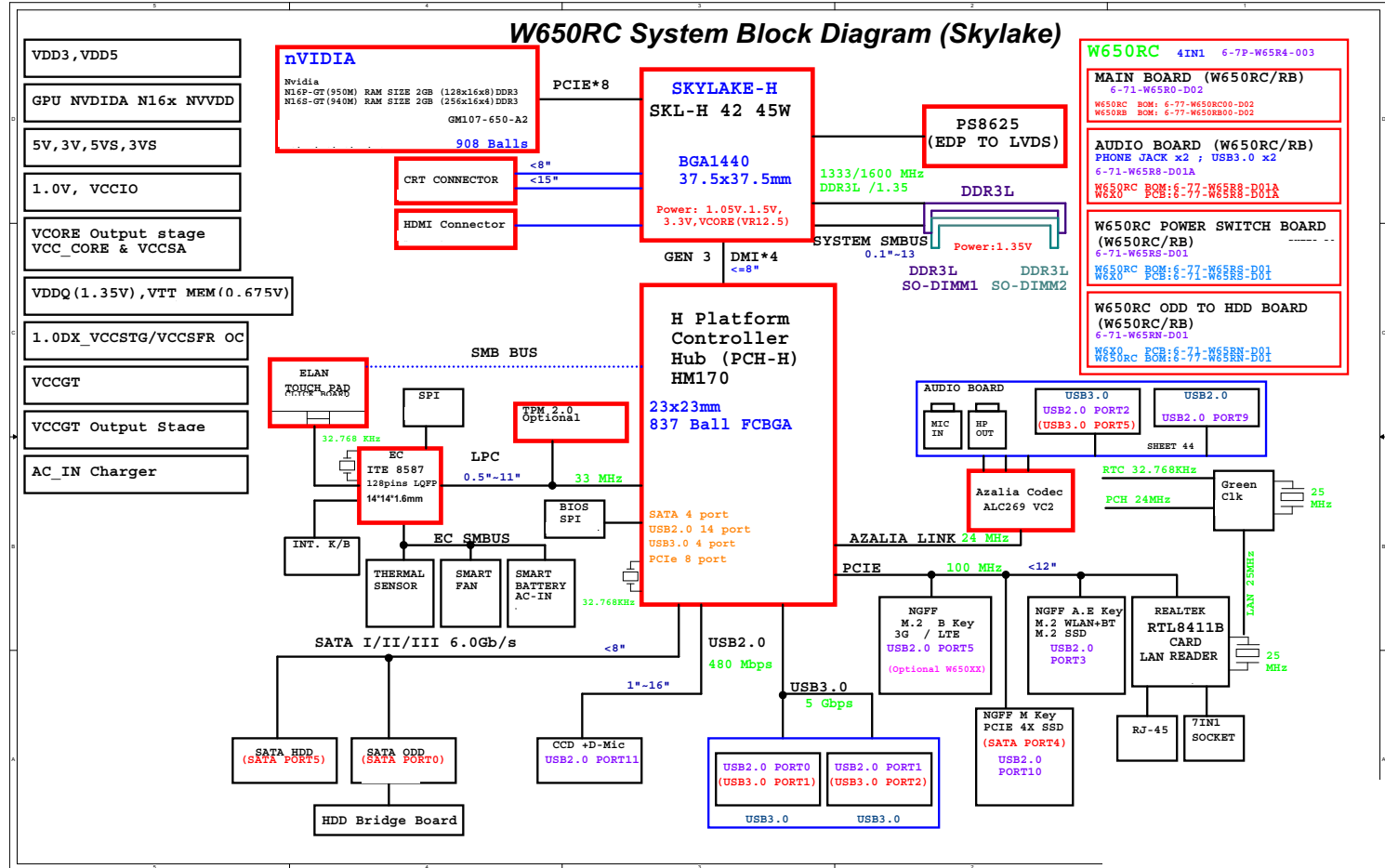

Sheet 1 of 51
System Block
Diagram

Processor 1/7

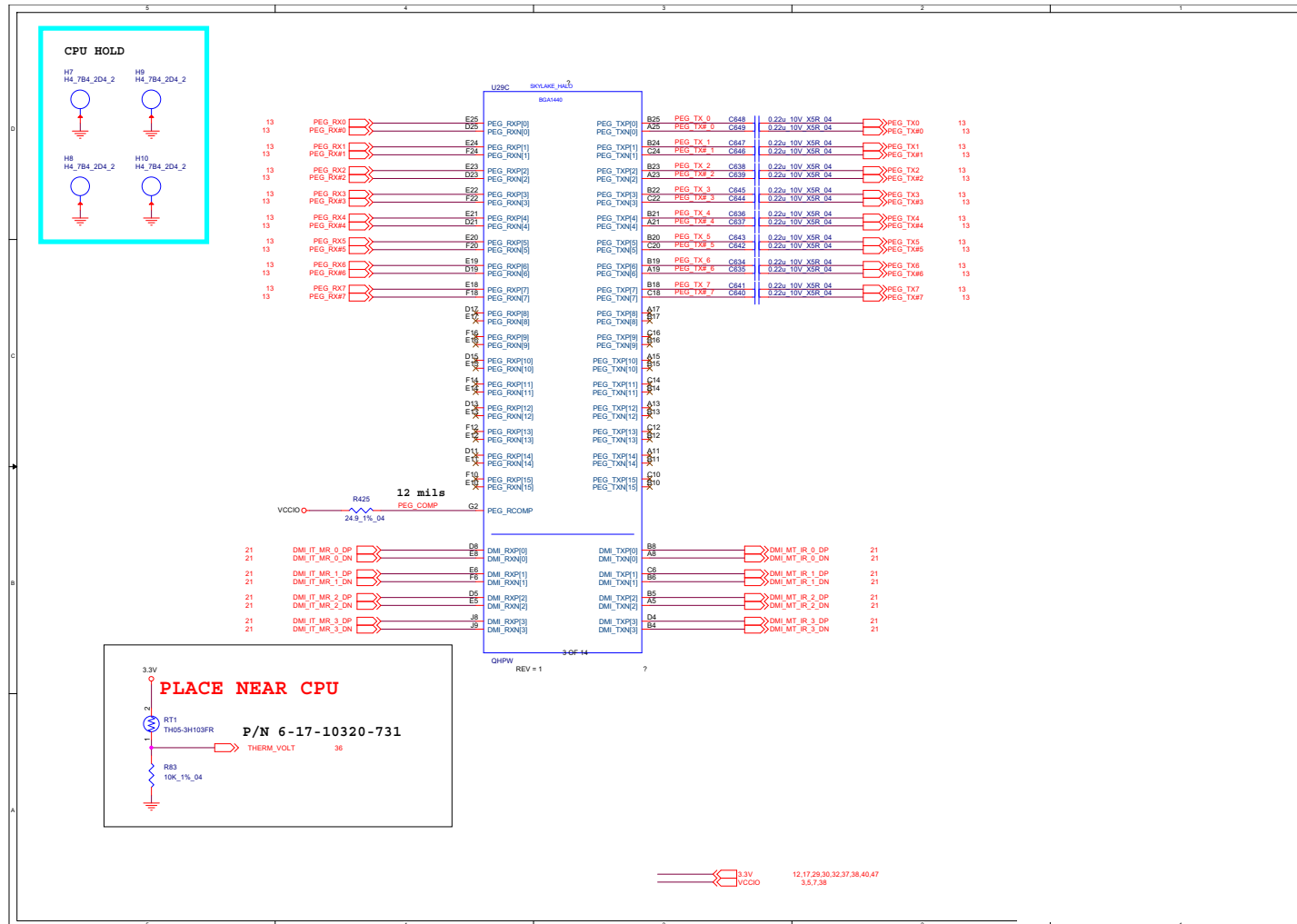

Sheet 2 of 51
Processor 1/7

B.Schematic Diagrams

Processor 2/7

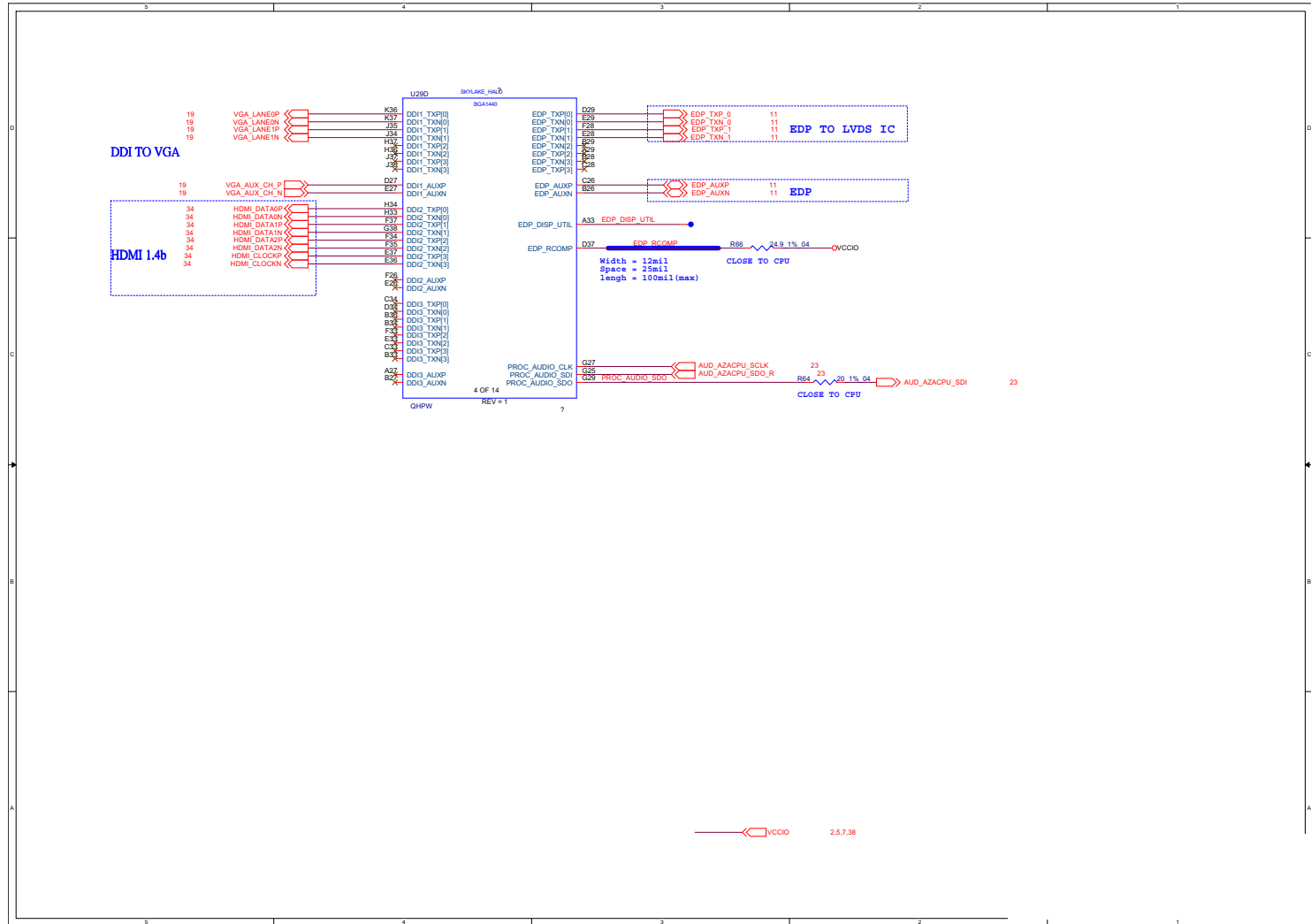

Sheet 3 of 51
Processor 2/7

B.Schematic Diagrams

Processor 3/7

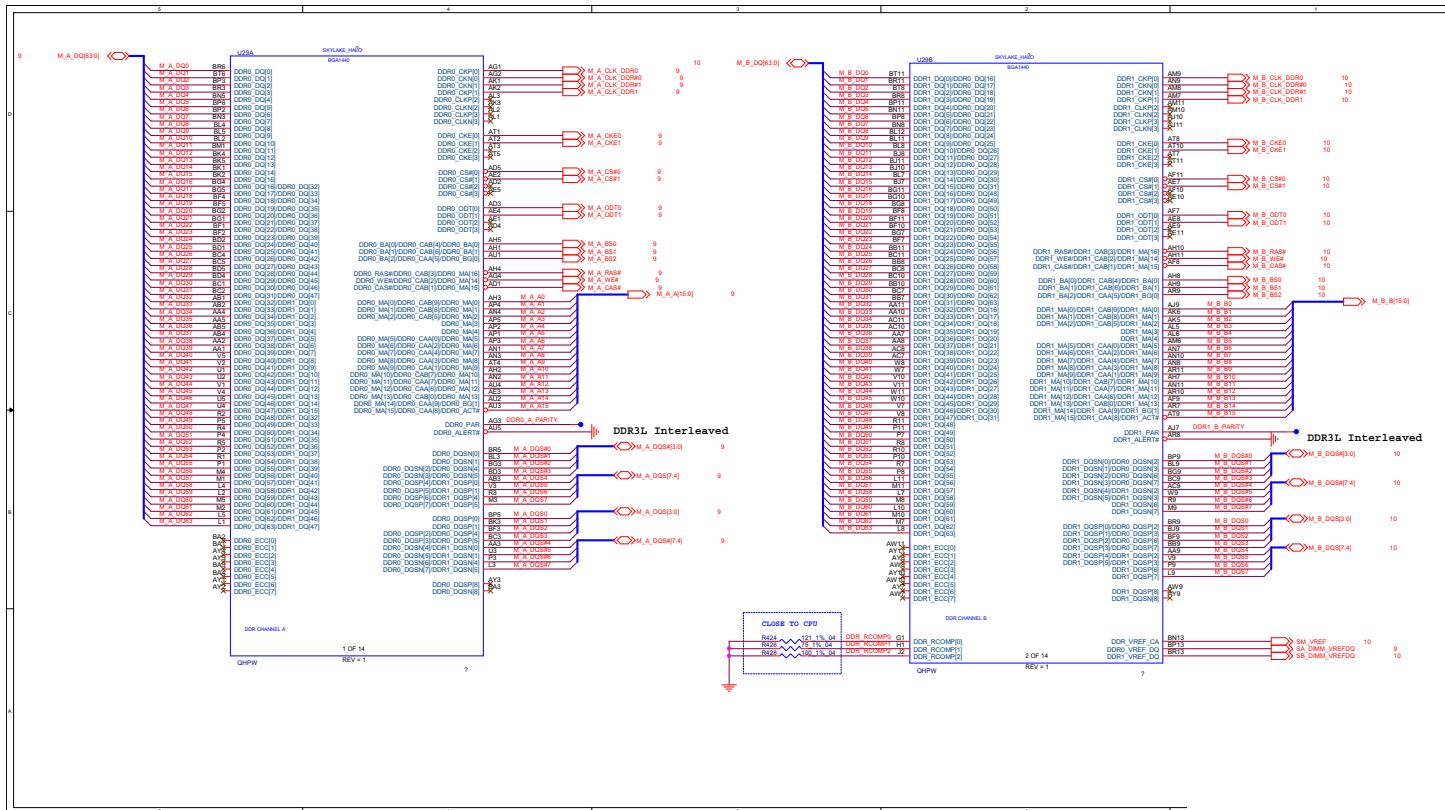

Sheet 4 of 51
Processor 3/7

B.Schematic Diagrams

Processor 4/7

Sheet 5 of 51
Processor 4/7

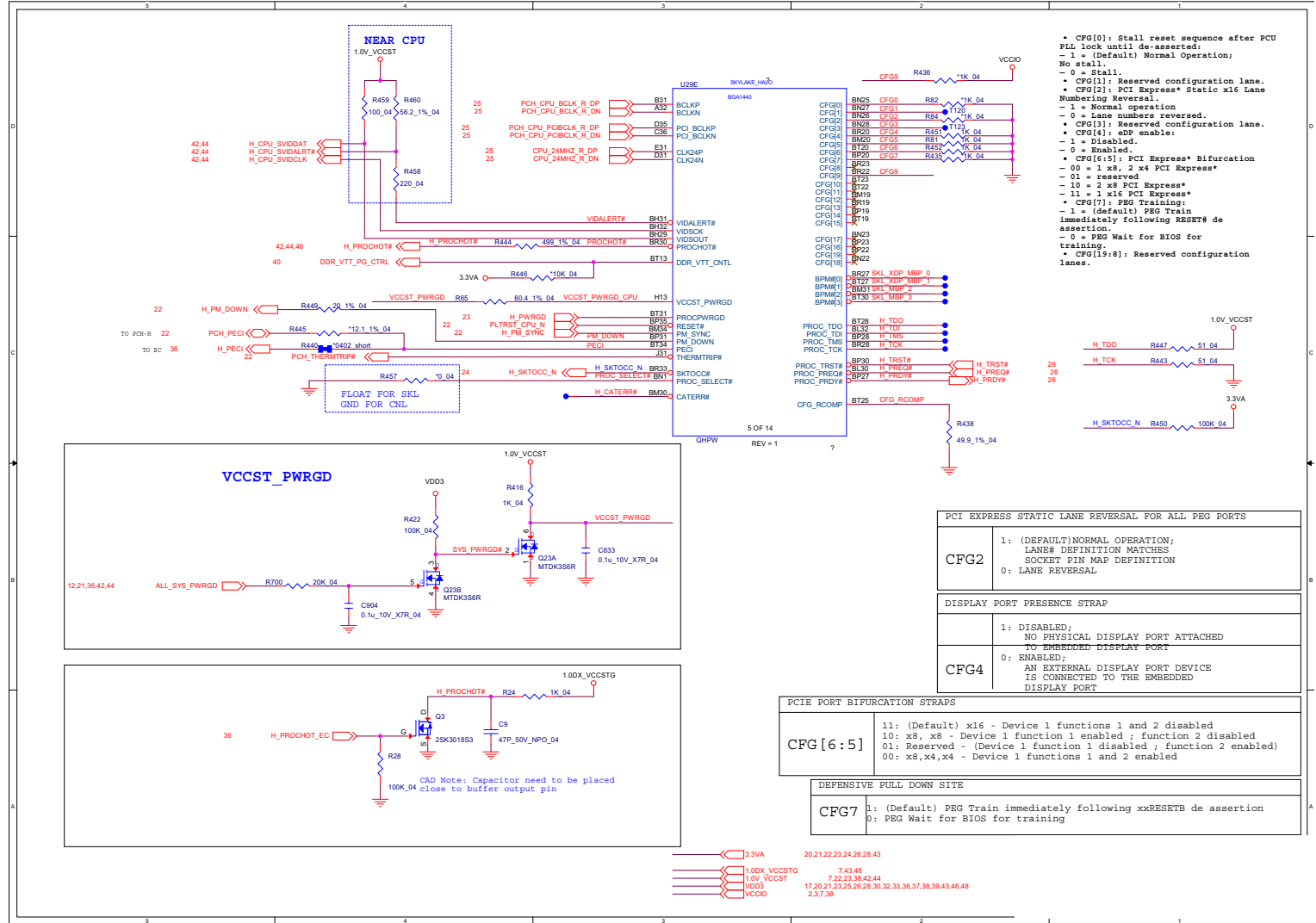

Processor 5/7

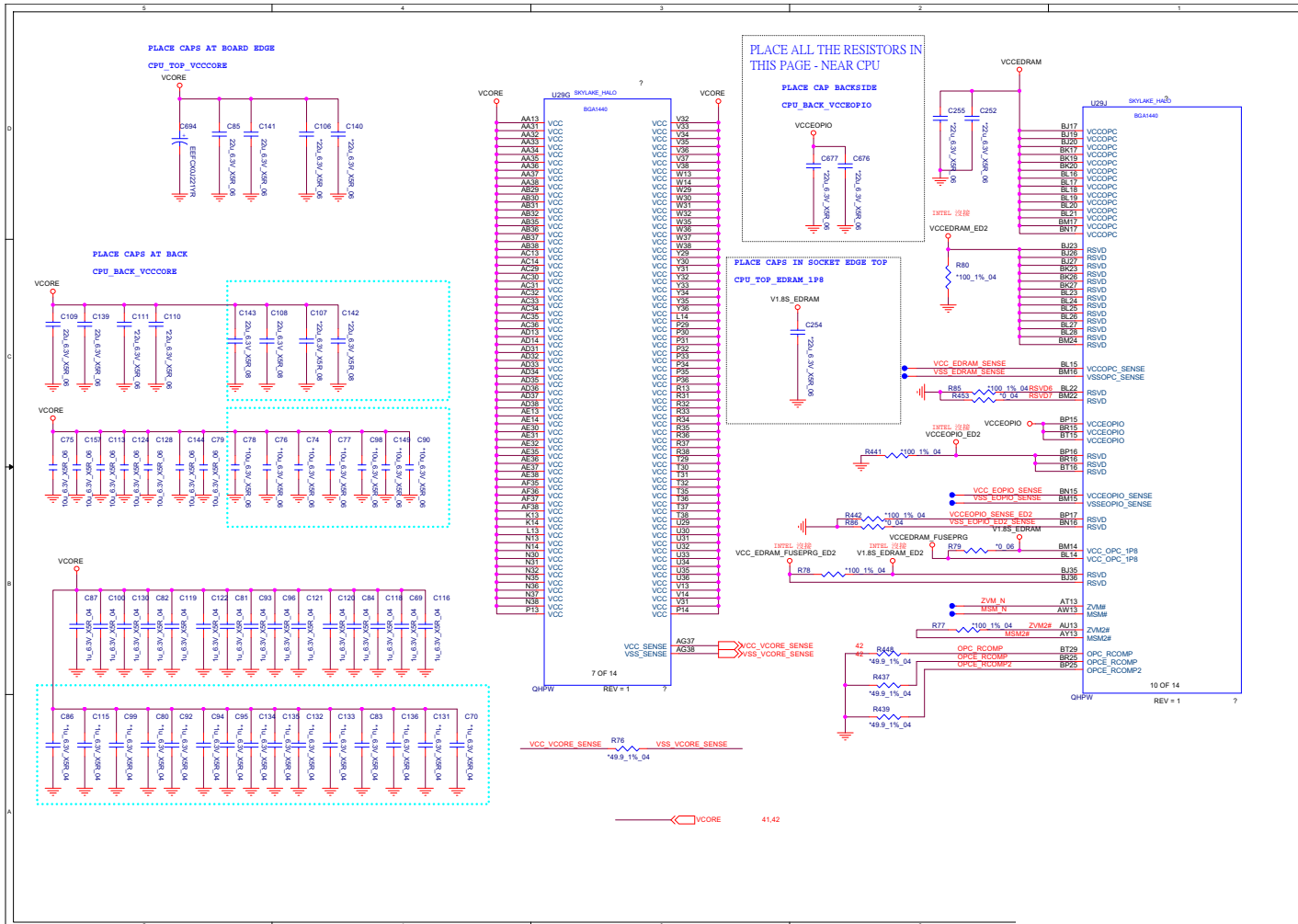

Sheet 6 of 51
Processor 5/7

Processor 6/7

Sheet 7 of 51
Processor 6/7

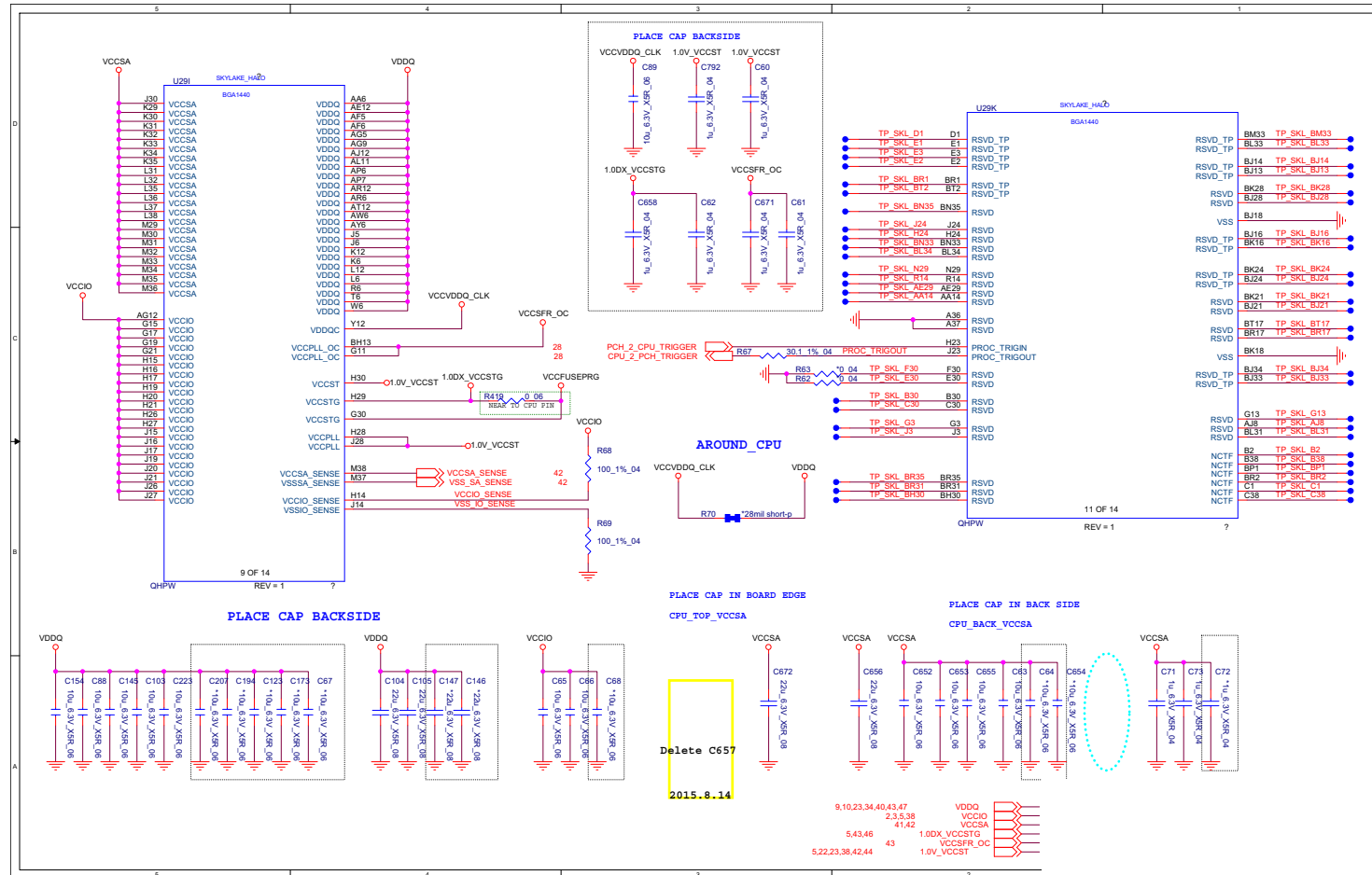

Processor 7/7

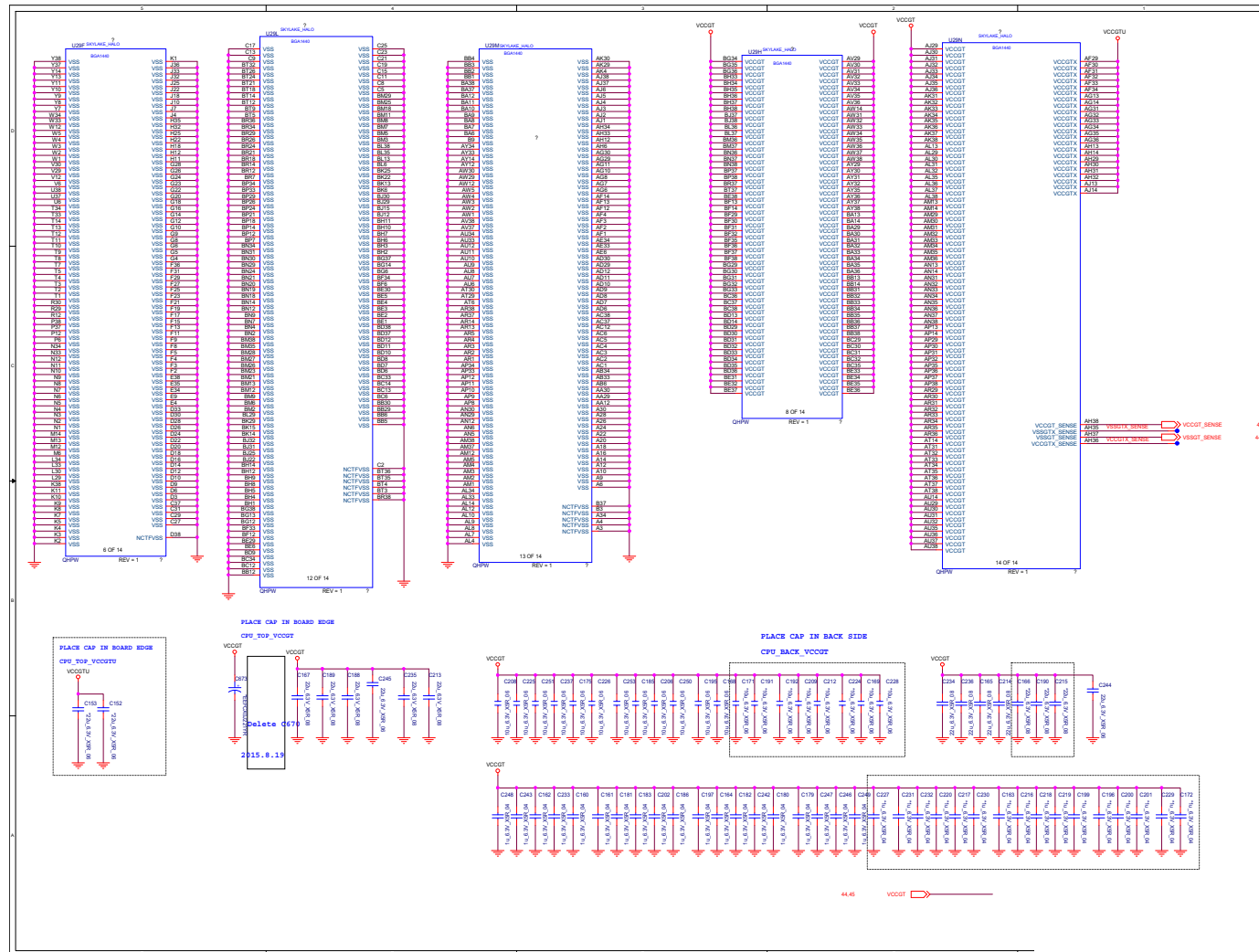

B.Schematic Diagrams

Sheet 8 of 51
Processor 7/7

Schematic Diagrams

DDR3 CHA SO-DIMM_0

Sheet 9 of 51
DDR3 CHA SO-DIMM_0

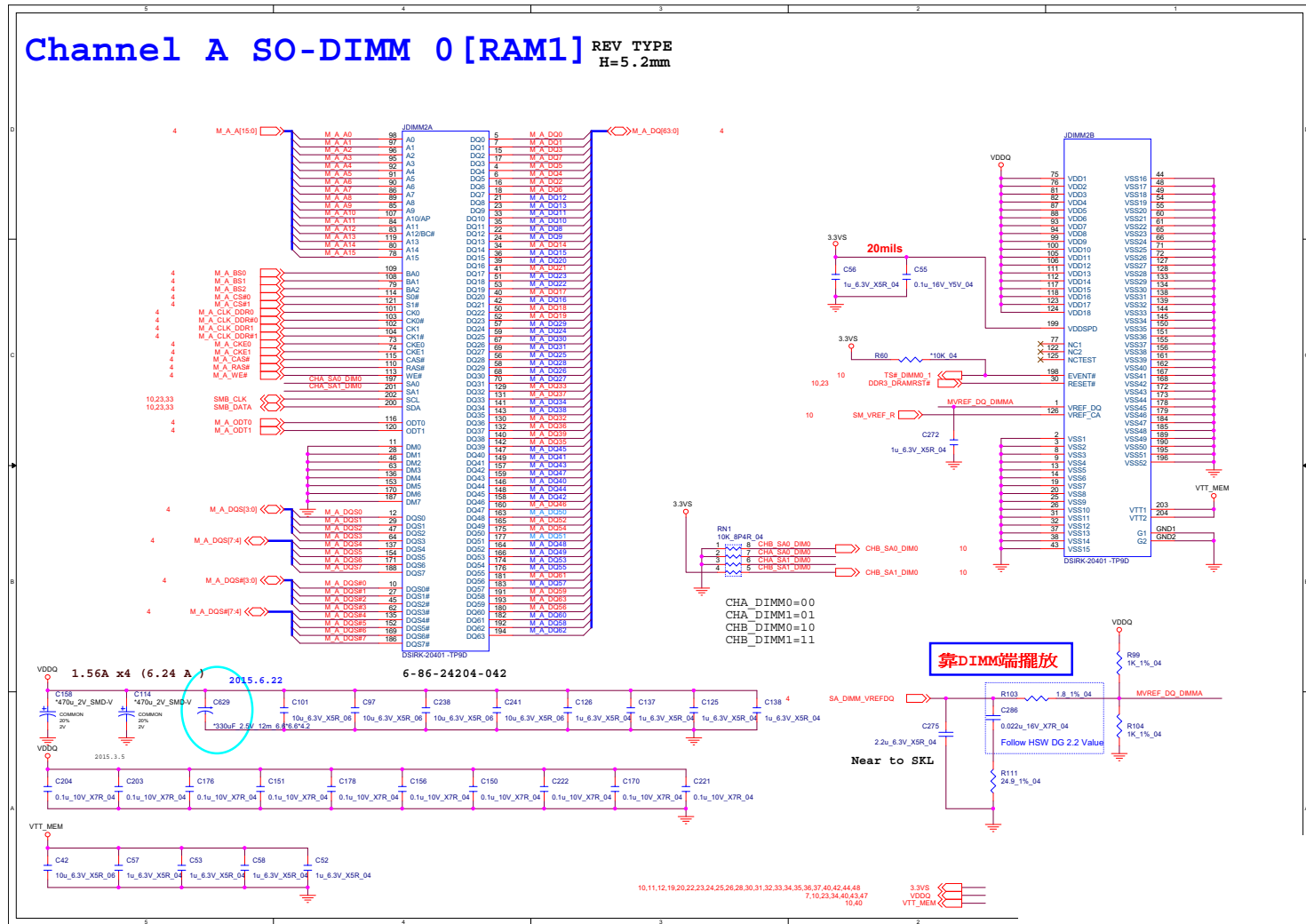

DDR3 CHB SO-DIMM_0

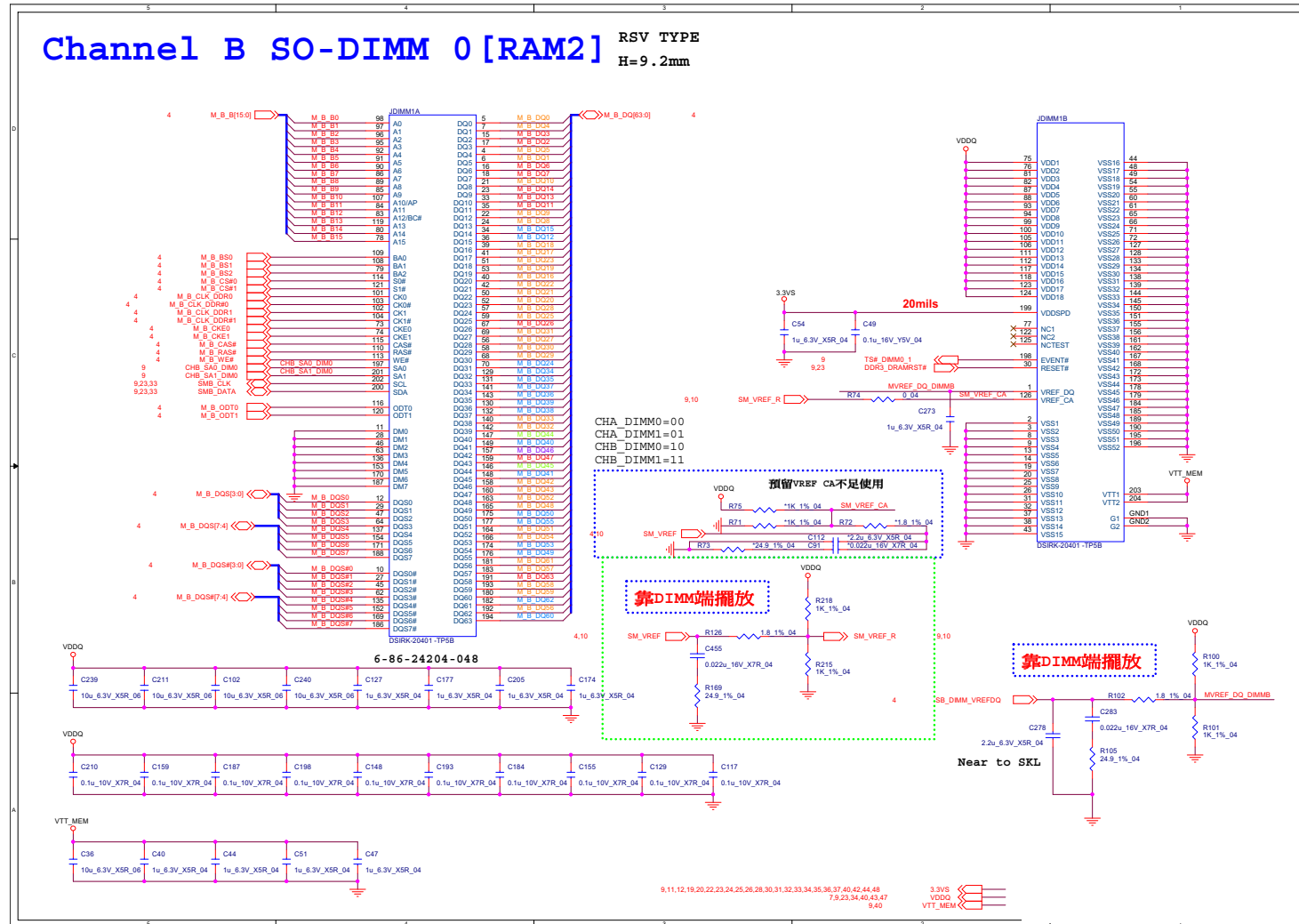

Sheet 10 of 51
DDR3 CHB SO-
DIMM_0

B. Schematic Diagrams

PANEL, INVERTER

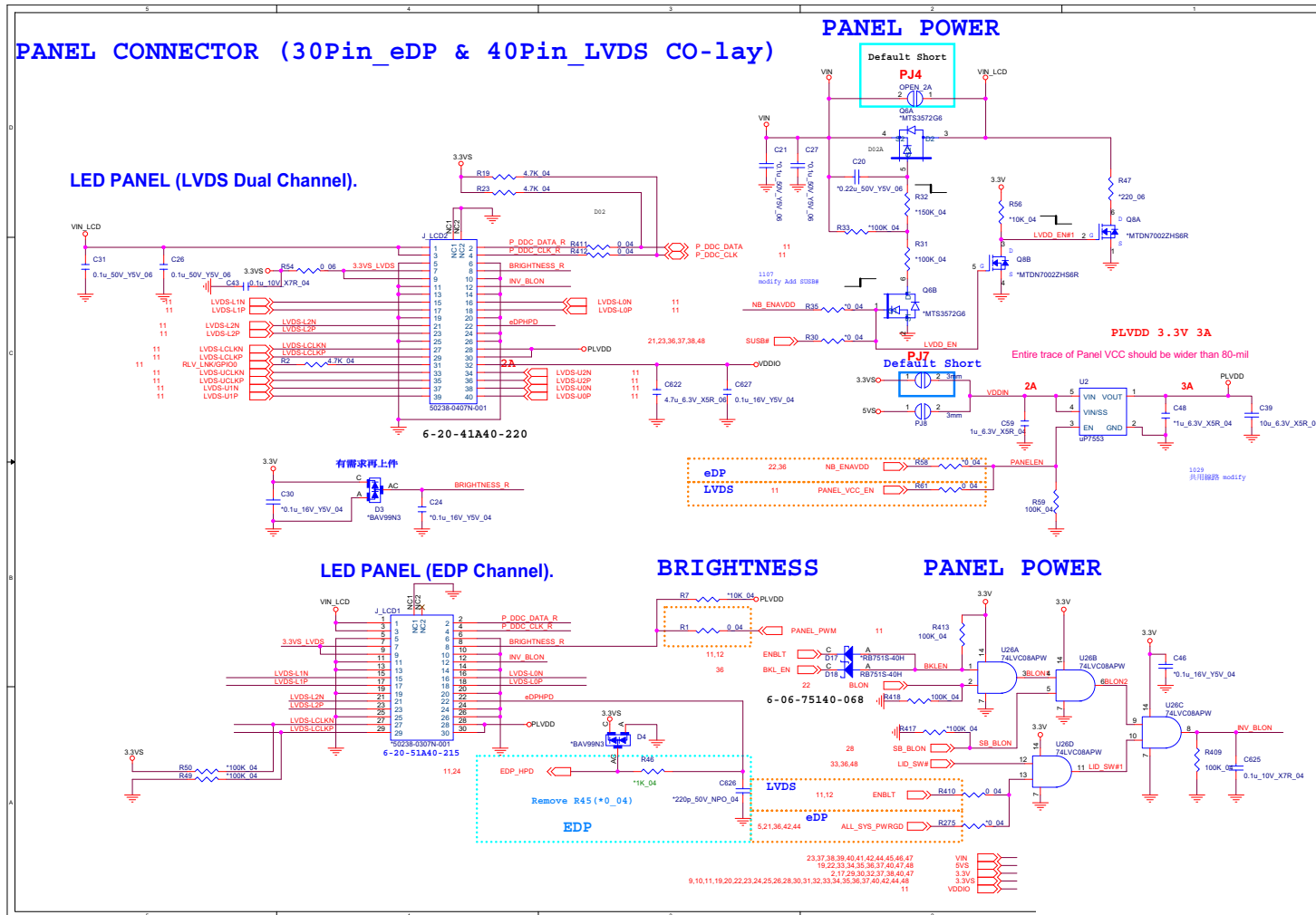

VGA Frame Buffer Interface

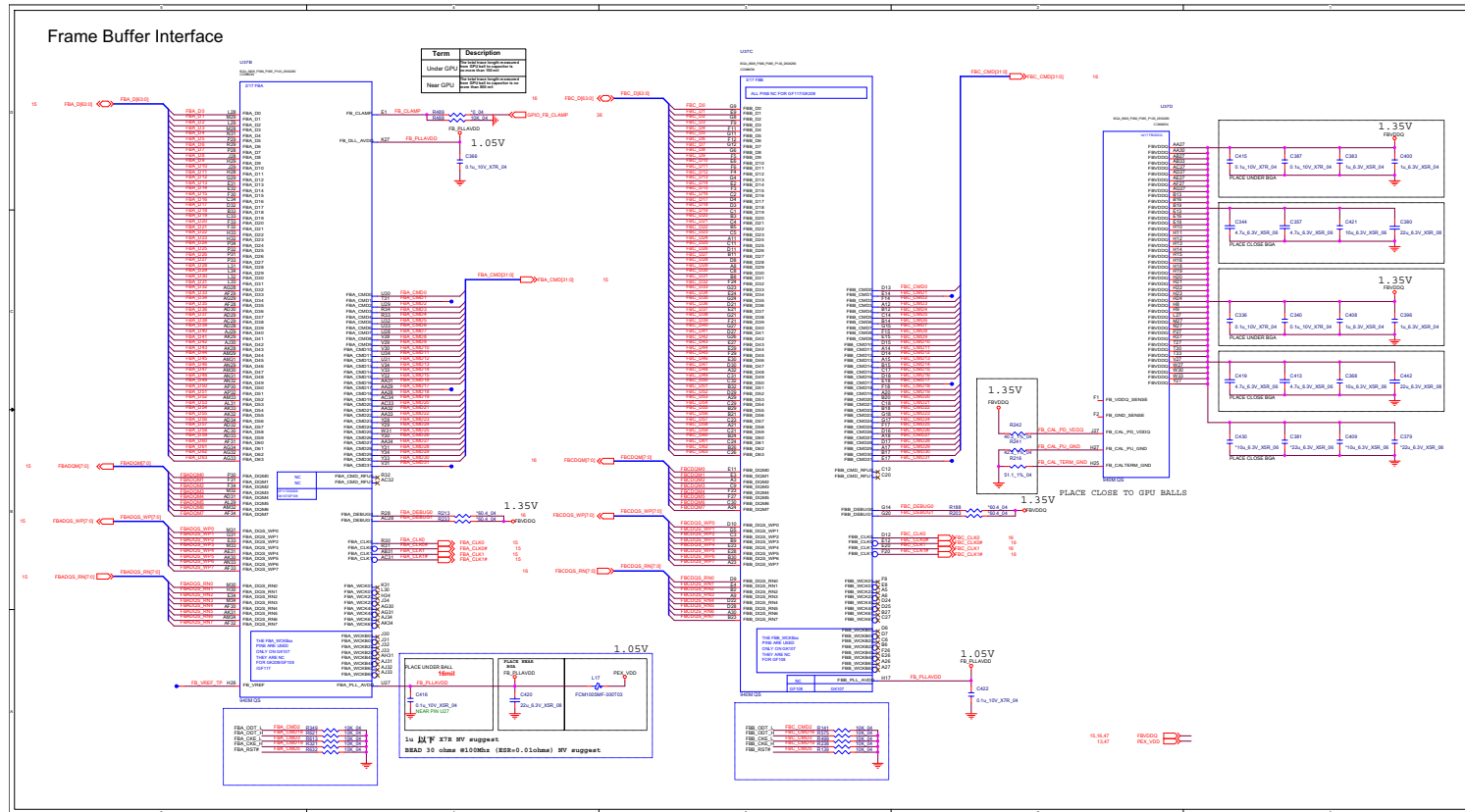

Sheet 14 of 51
VGA Frame Buffer Interface

B.Schematic Diagrams

VGA Frame Buffer A

Sheet 15 of 51
VGA Frame Buffer
A

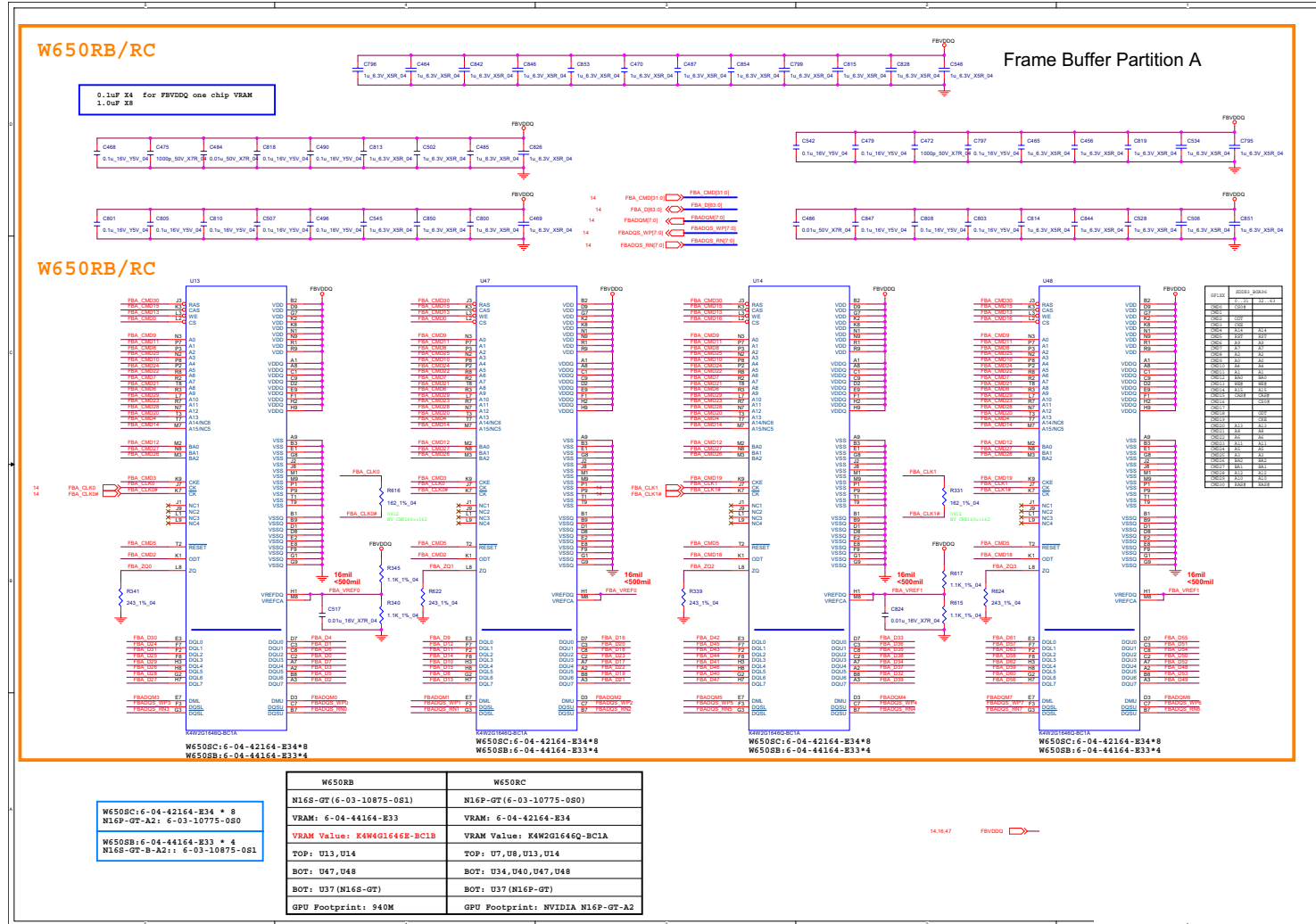

VGA Frame Buffer C

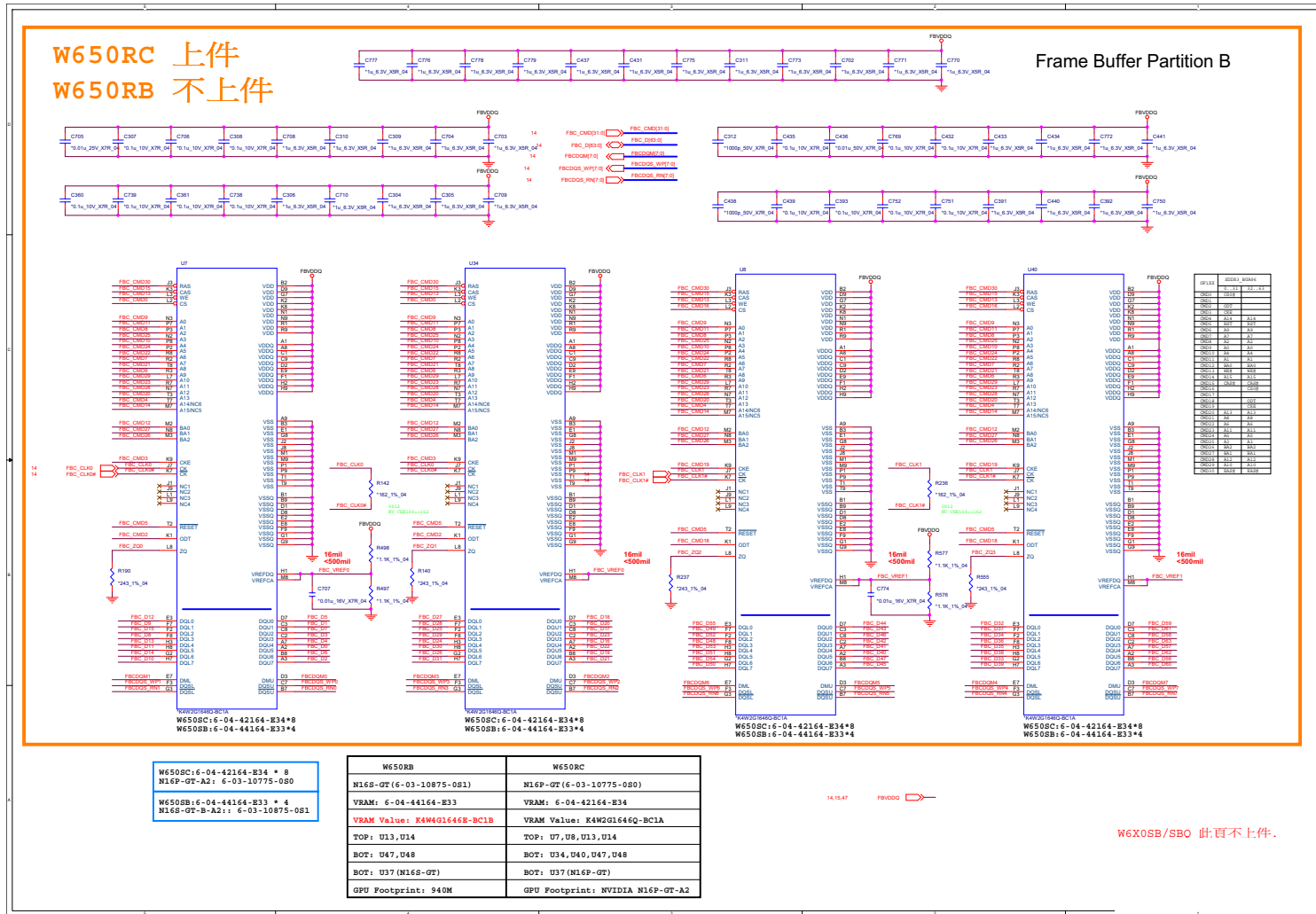

Sheet 16 of 51
VGA Frame Buffer
C

B.Schematic Diagrams

VGA NVVDD Decoupling

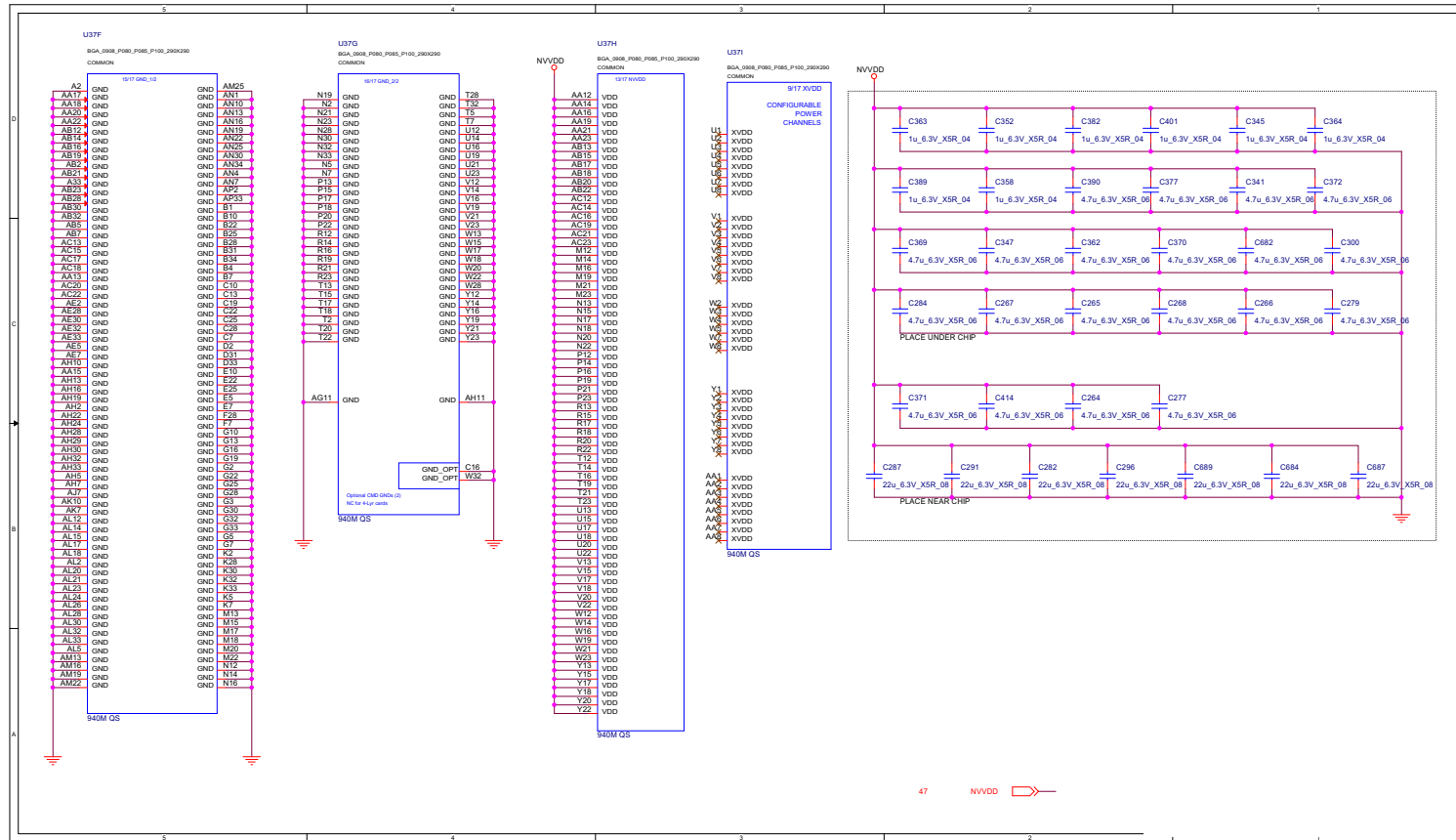

Sheet 18 of 51
VGA NVVDD
Decoupling

B.Schematic Diagrams

CRT

Sheet 19 of 51
CRT

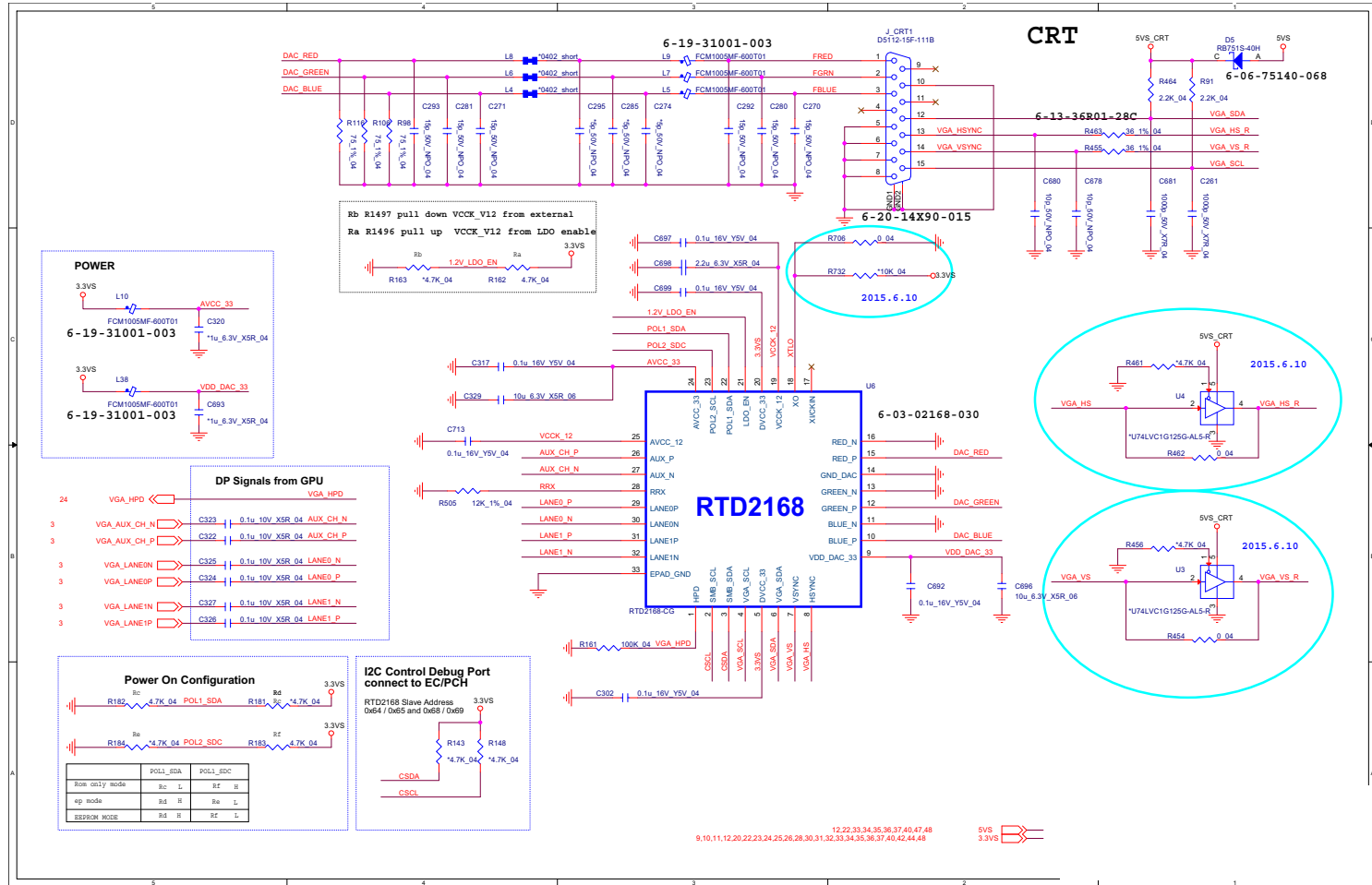

PCH 1/9

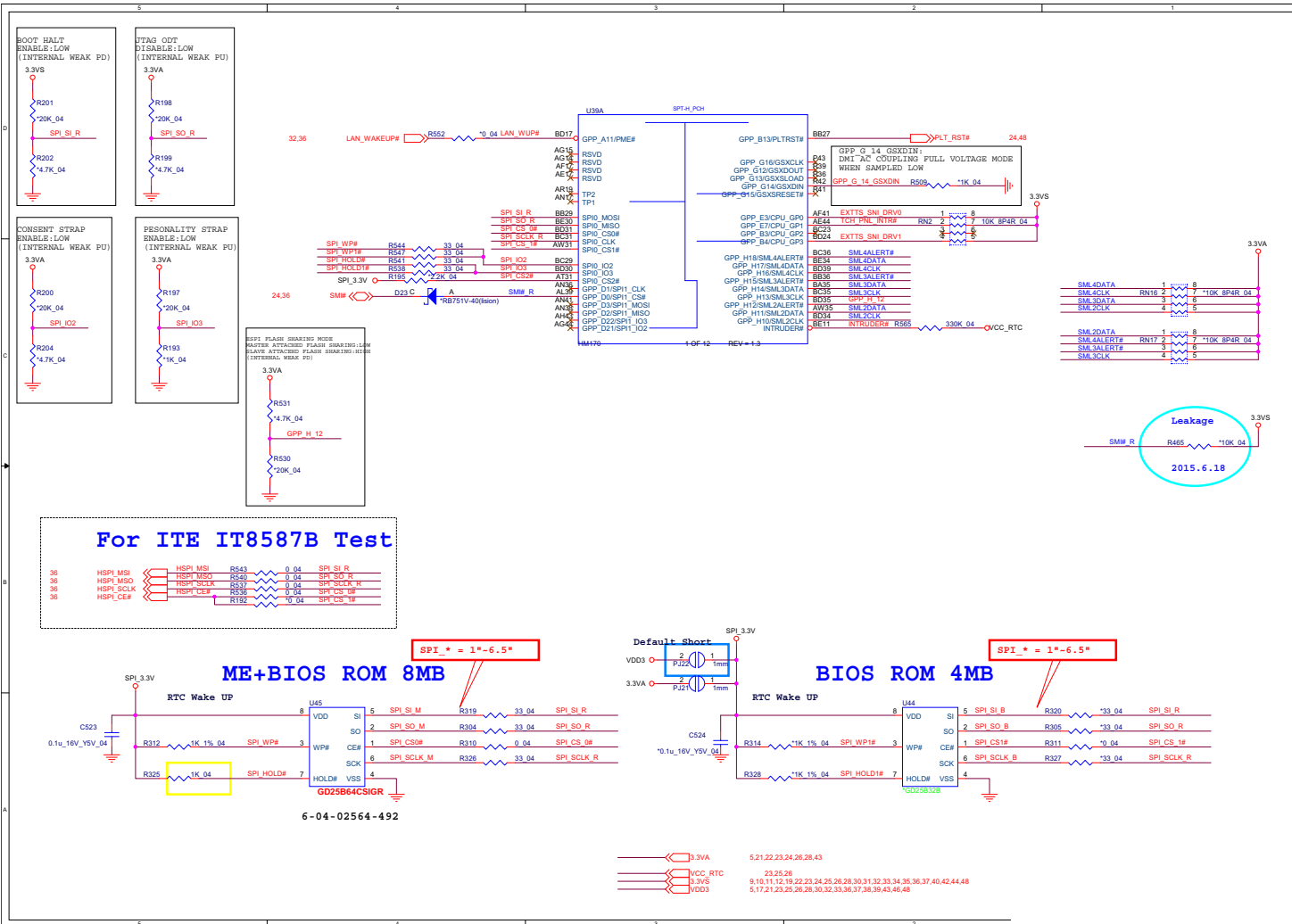

Sheet 20 of 51
PCH 1/9

B.Schematic Diagrams

PCH 2/9

Sheet 21 of 51
PCH 2/9

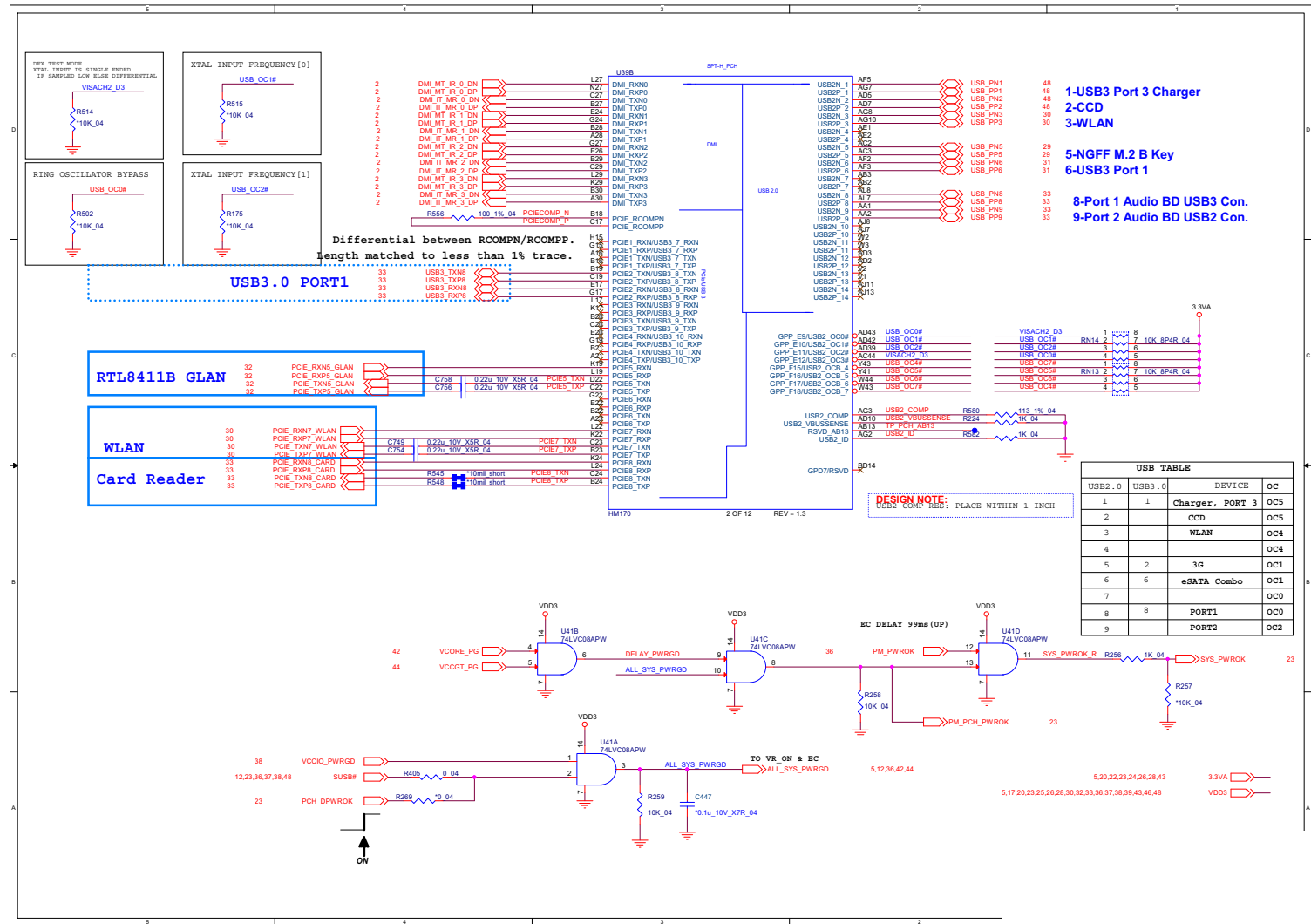

- 1-USB3 Port 3 Charger
- 2-CCD
- 3-WLAN
- 5-NGFF M.2 B Key
- 6-USB3 Port 1
- 8-Port 1 Audio BD USB3 Con.
- 9-Port 2 Audio BD USB2 Con.

PCH 3/9

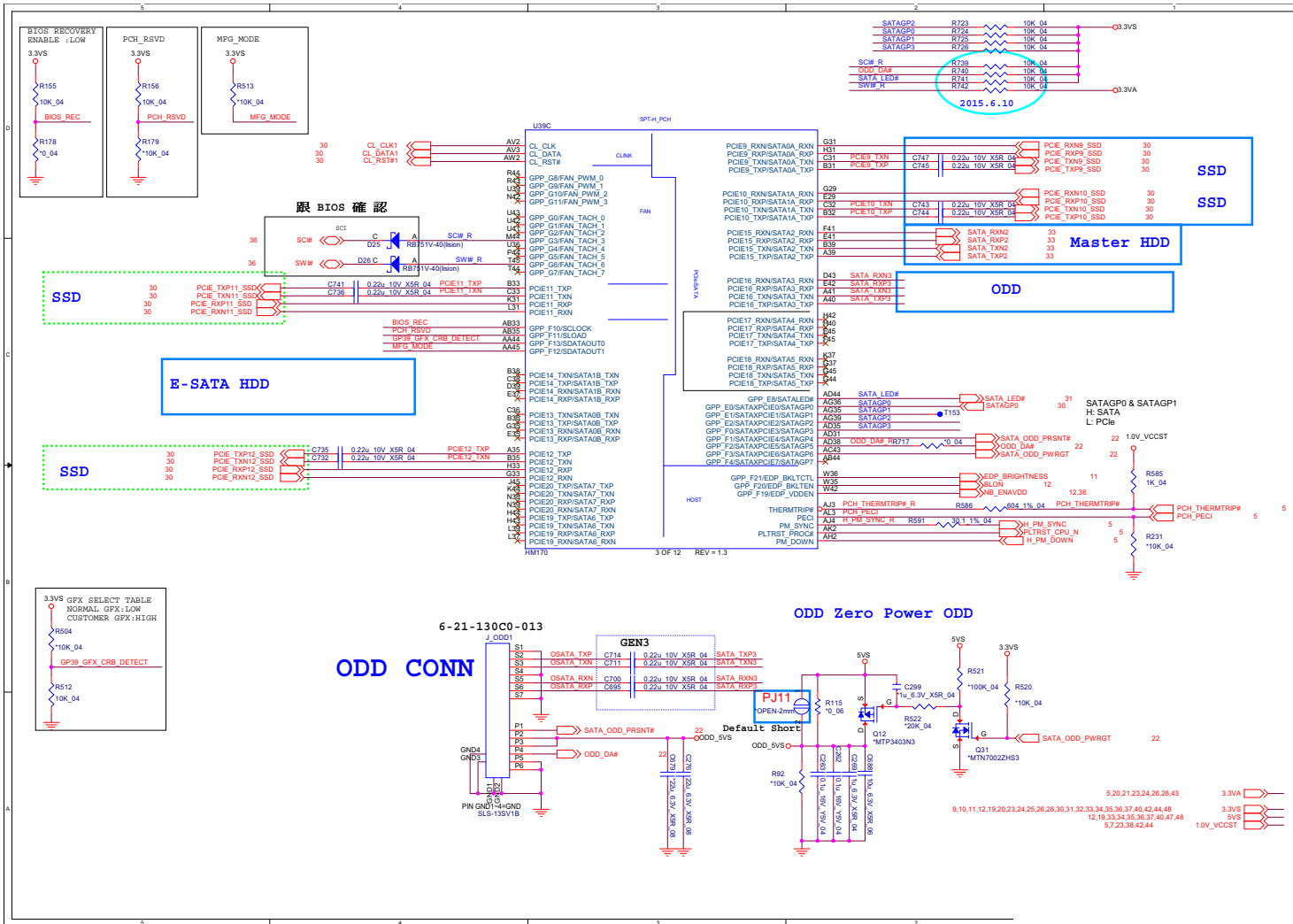

Sheet 22 of 51
PCH 3/9

B.Schematic Diagrams

PCH 4/9

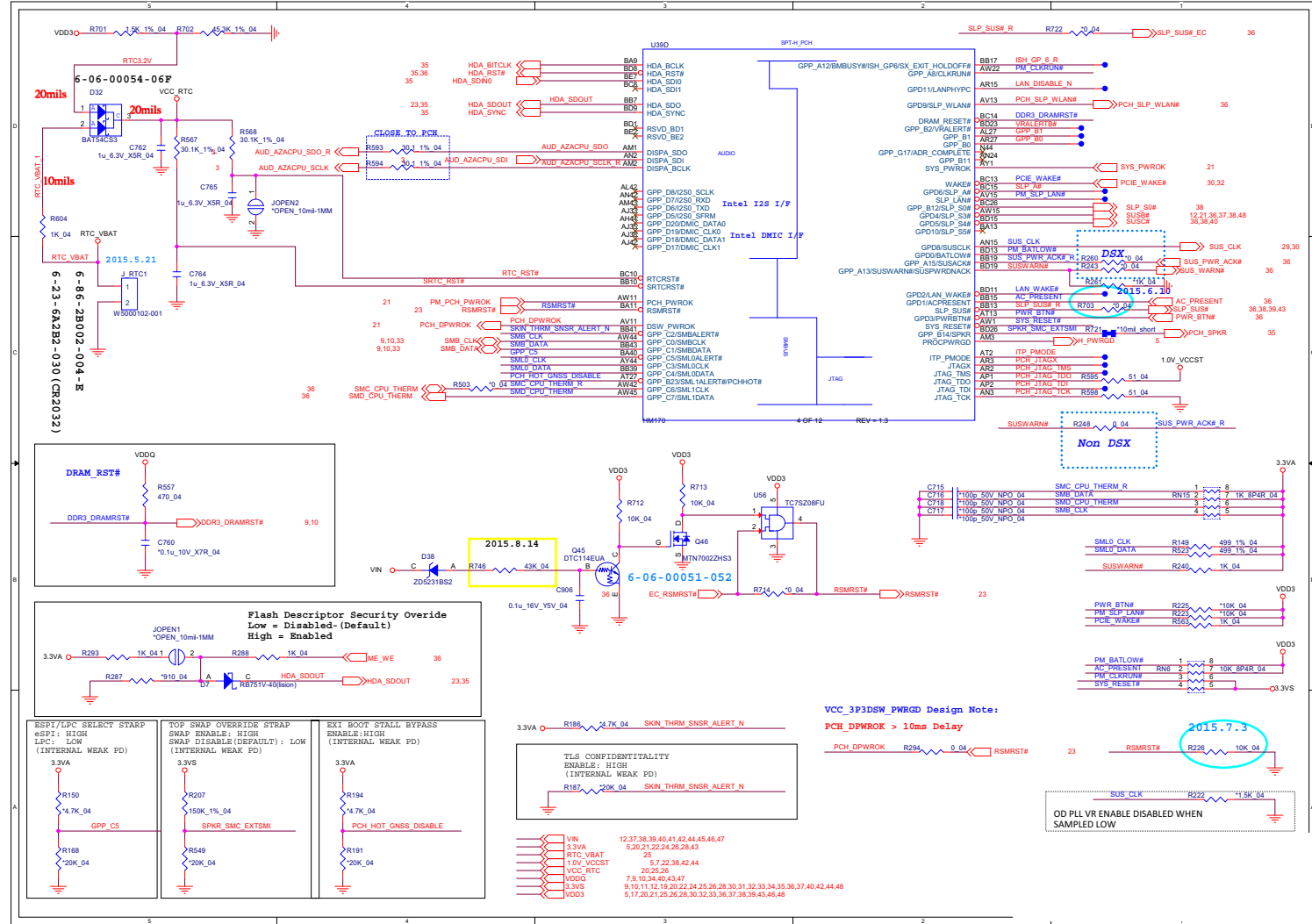

PCH 5/9

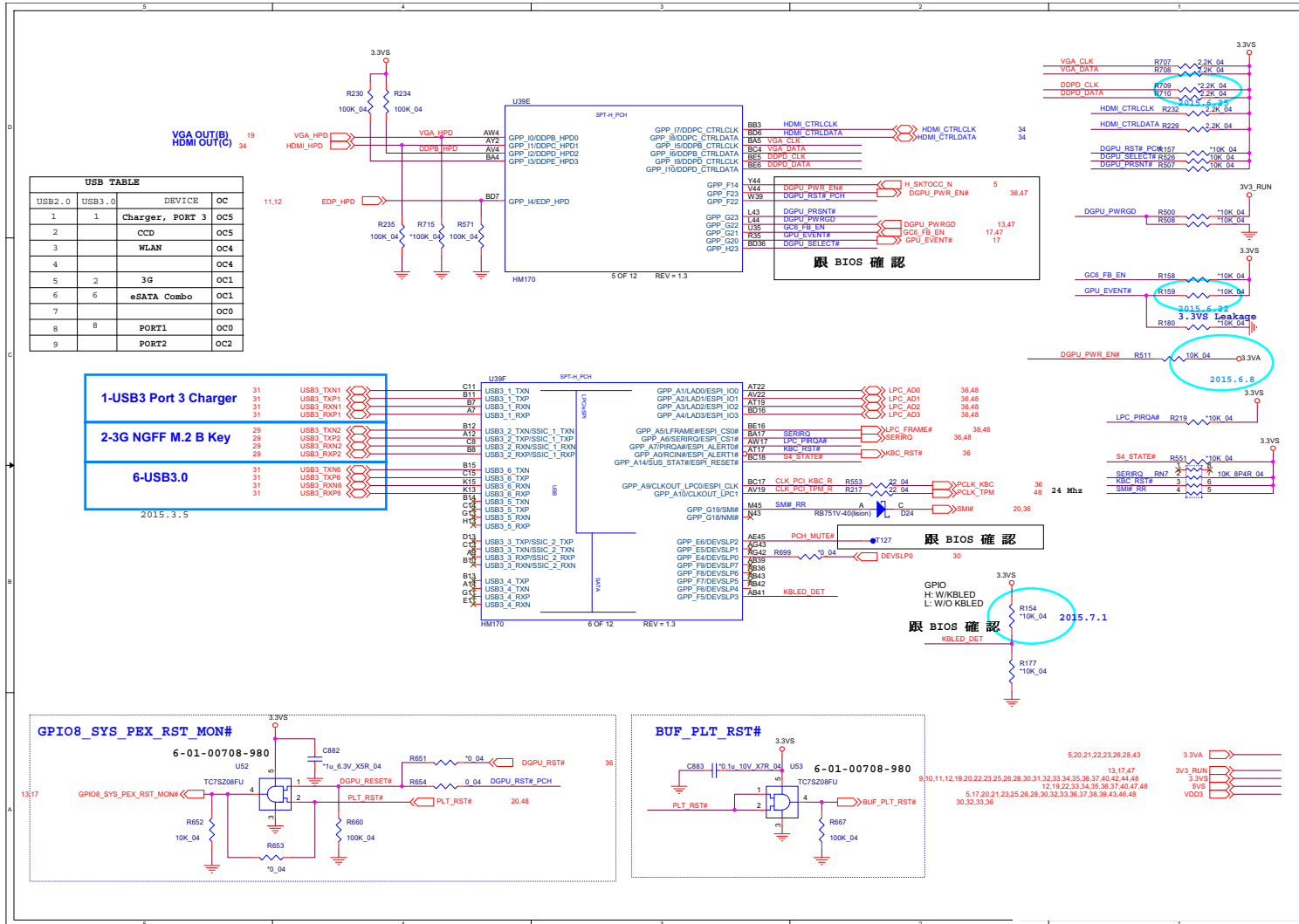

B.Schematic Diagrams

Sheet 24 of 51
PCH 5/9

Schematic Diagrams

PCH 6/9

B.Schematic Diagrams

Sheet 25 of 51
PCH 6/9

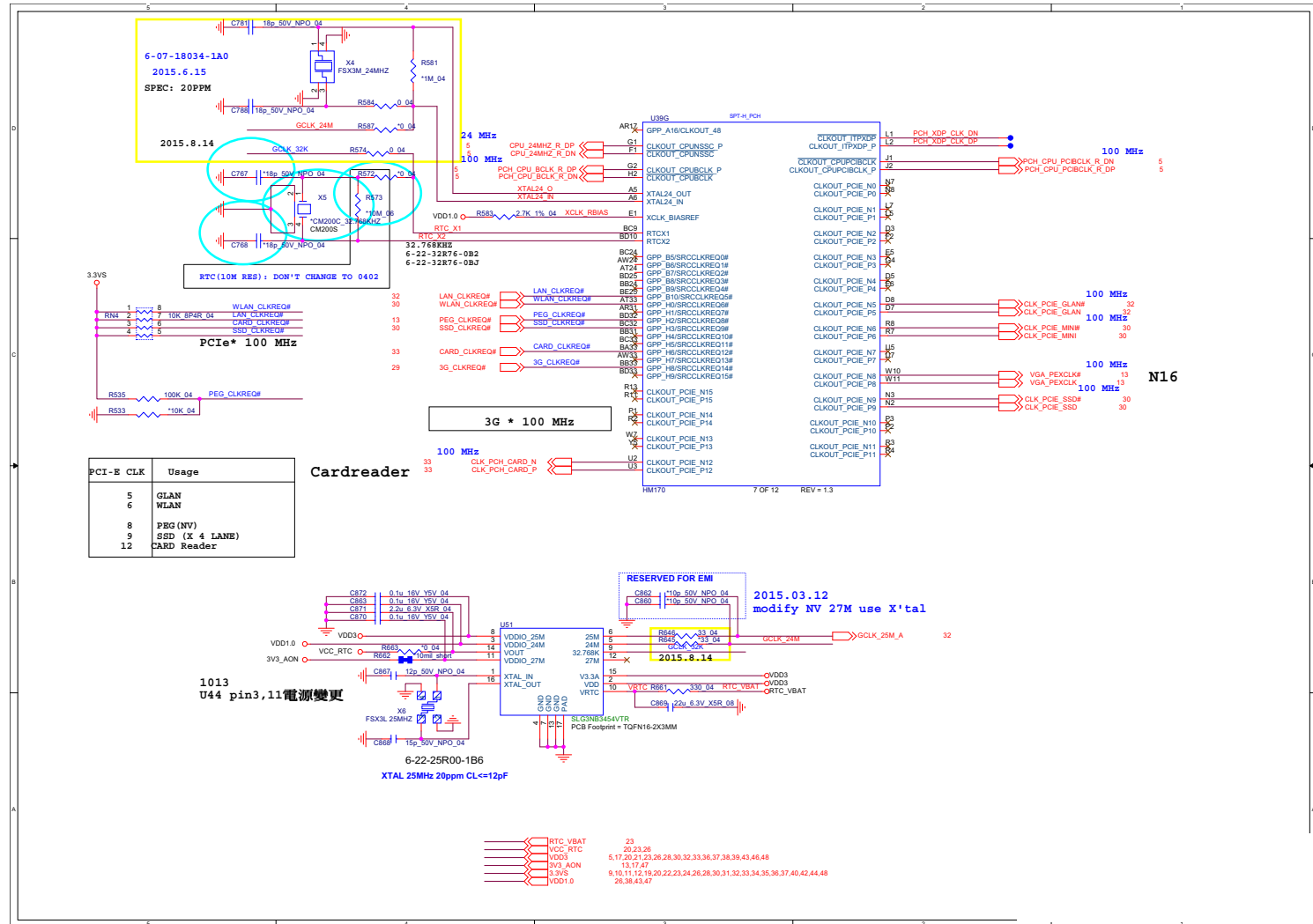

PCH 7/9

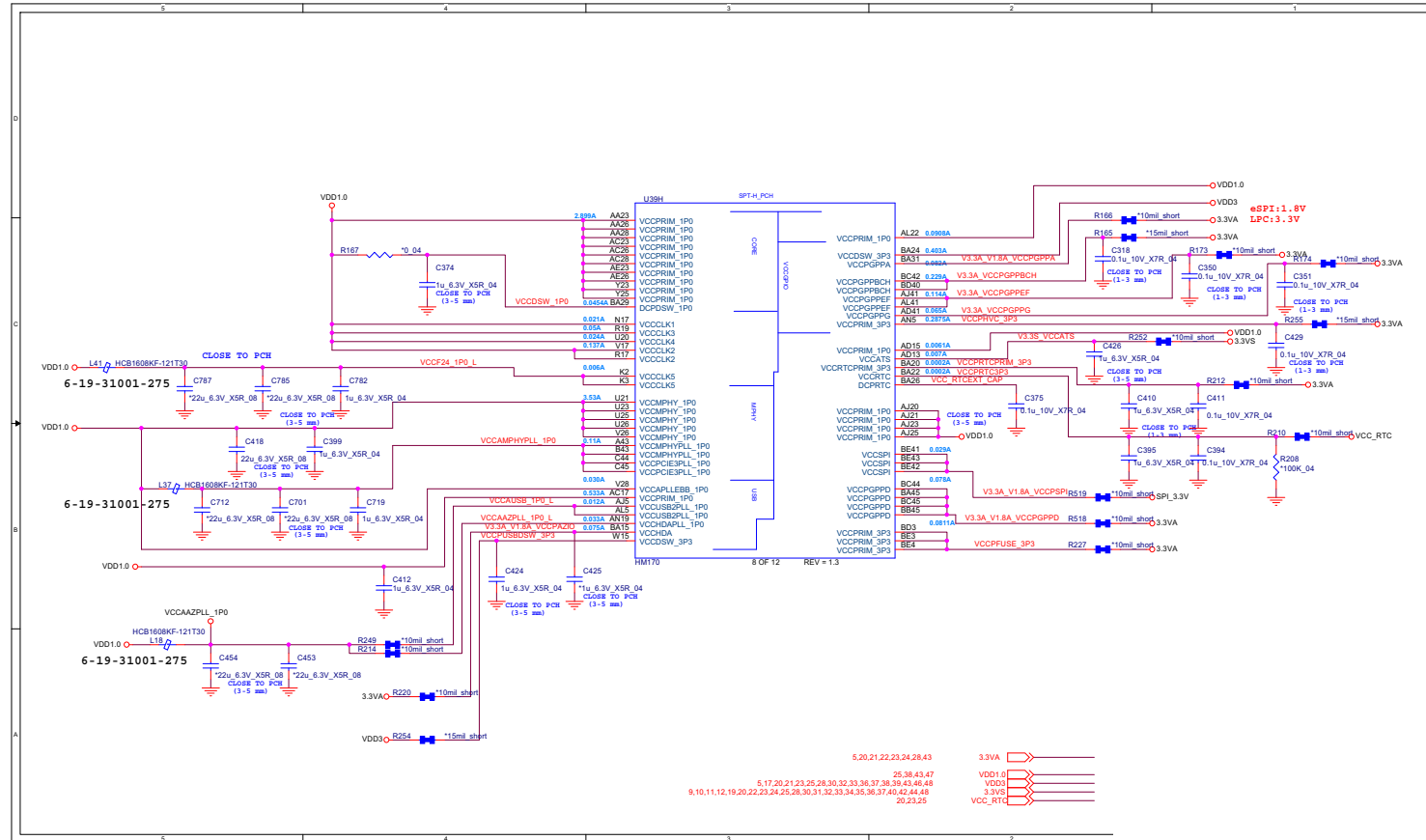

Sheet 26 of 51
PCH 7/9

B.Schematic Diagrams

PCH 8/9

Sheet 27 of 51
PCH 8/9

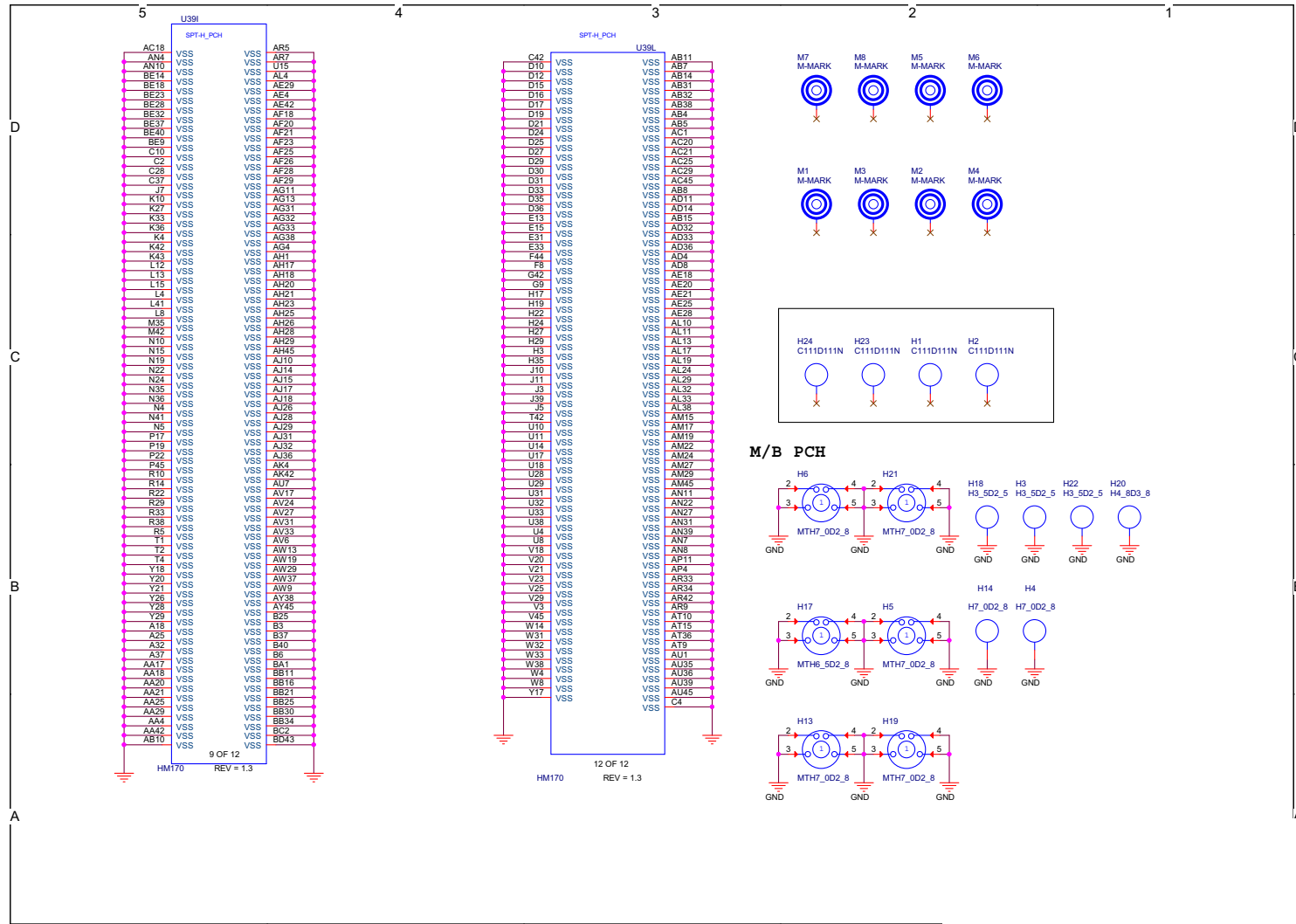

PCH 9/9

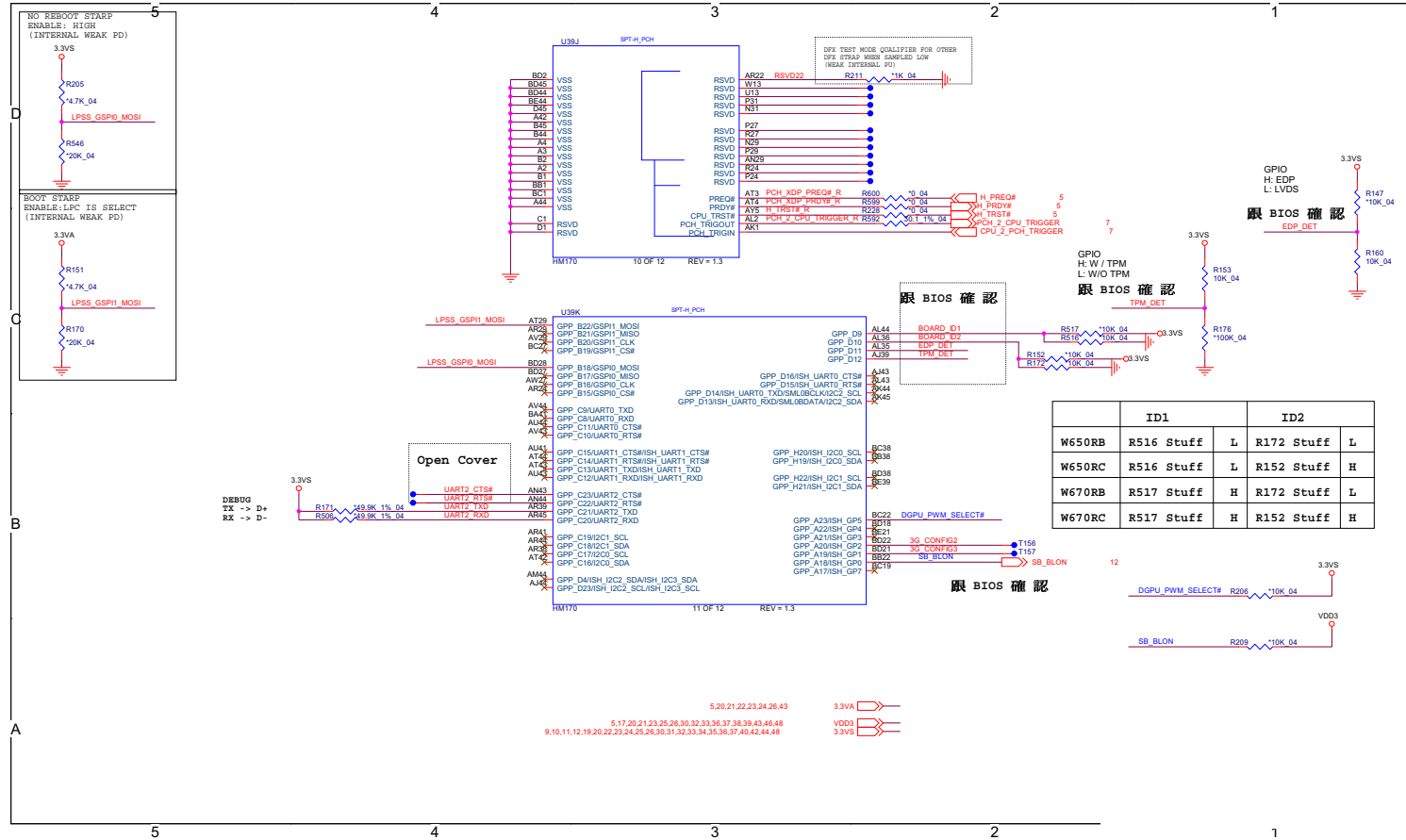

Sheet 28 of 51
PCH 9/9

M.2 3G + M.2 SATA

Sheet 29 of 51
M.2 3G + M.2 SATA

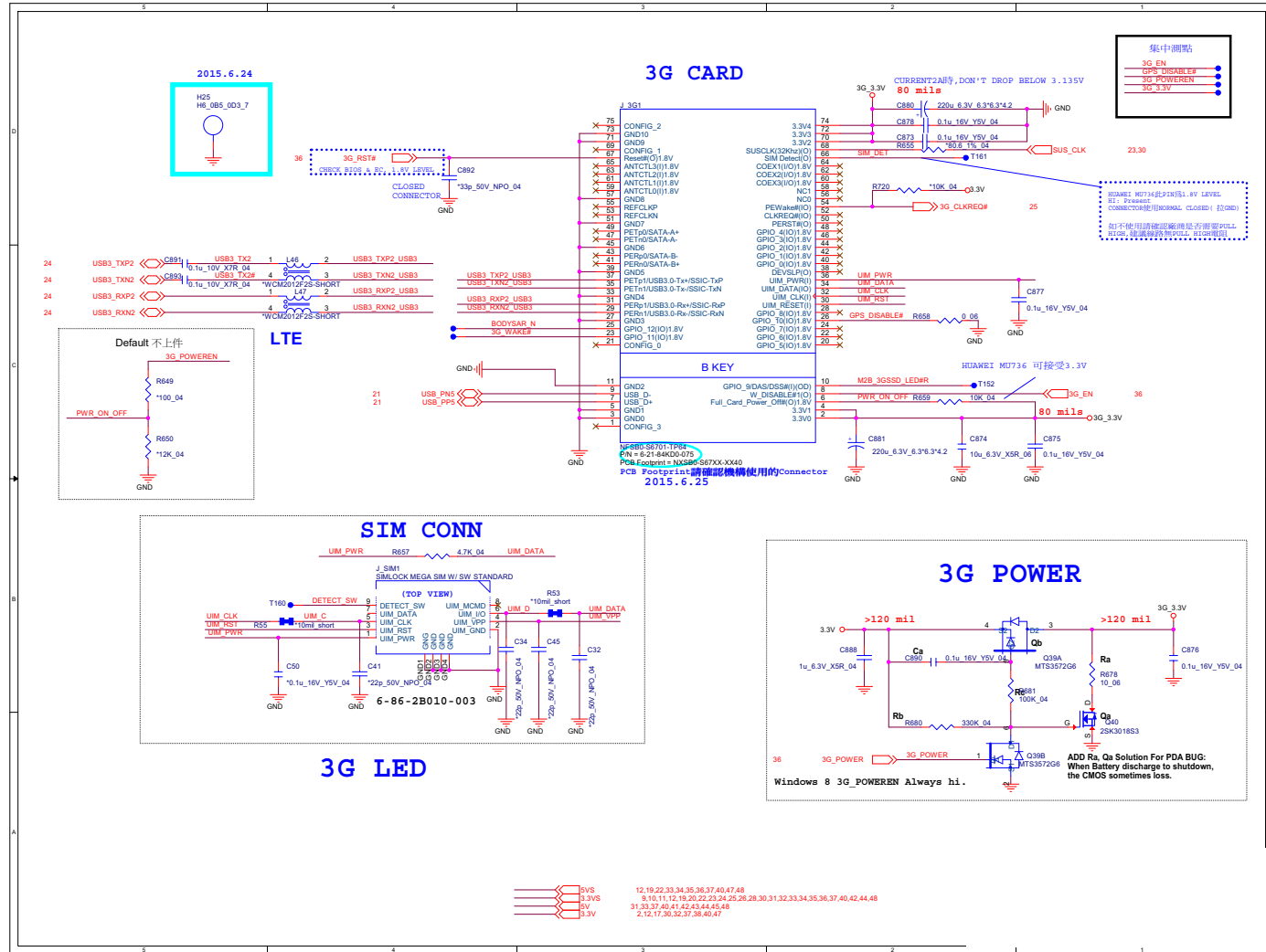

M.2 WLAN+BT, PCIE4X SSD

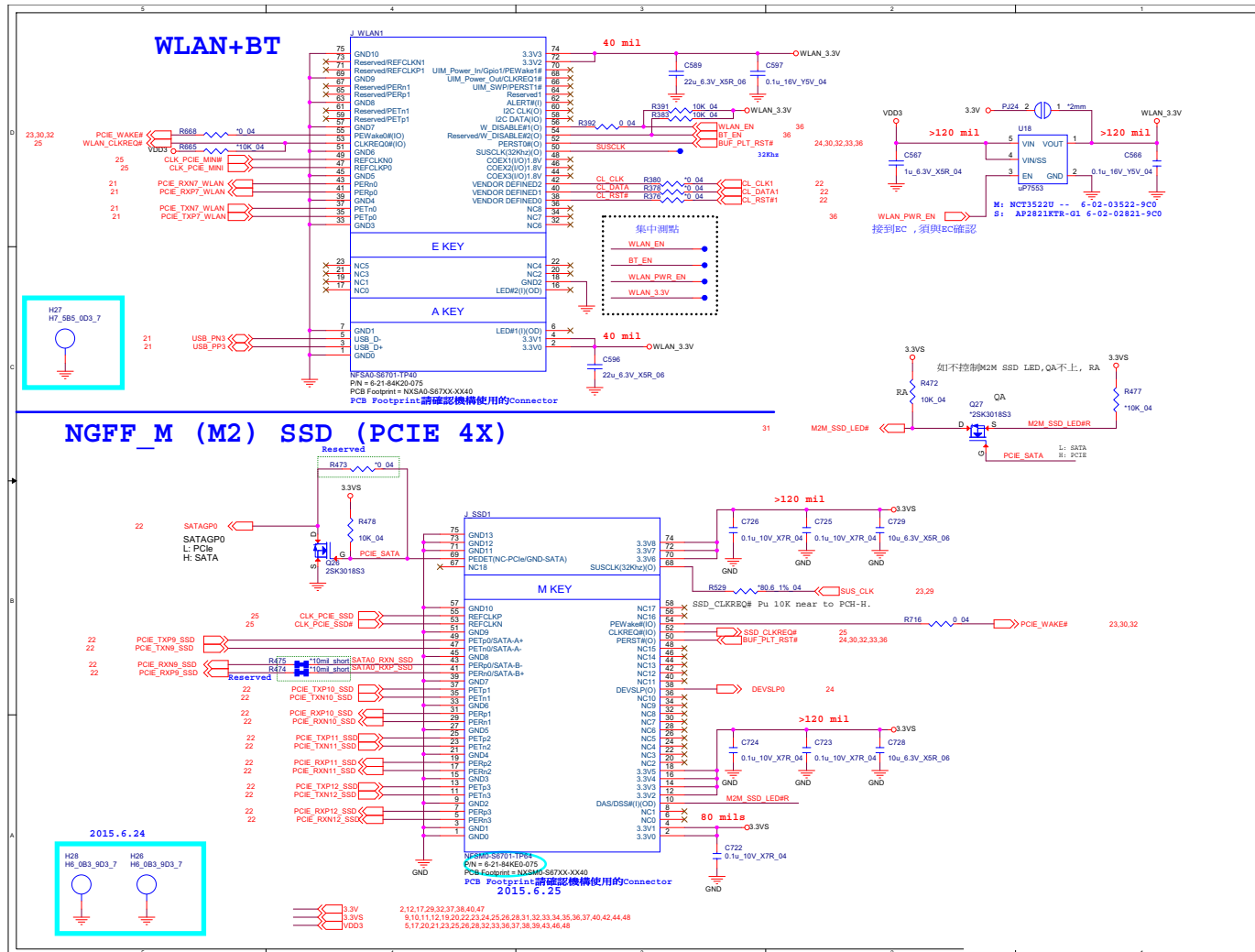

B.Schematic Diagrams

Sheet 30 of 51
 M.2 WLAN+BT,
 PCIE4X SSD

USB3.0, LED

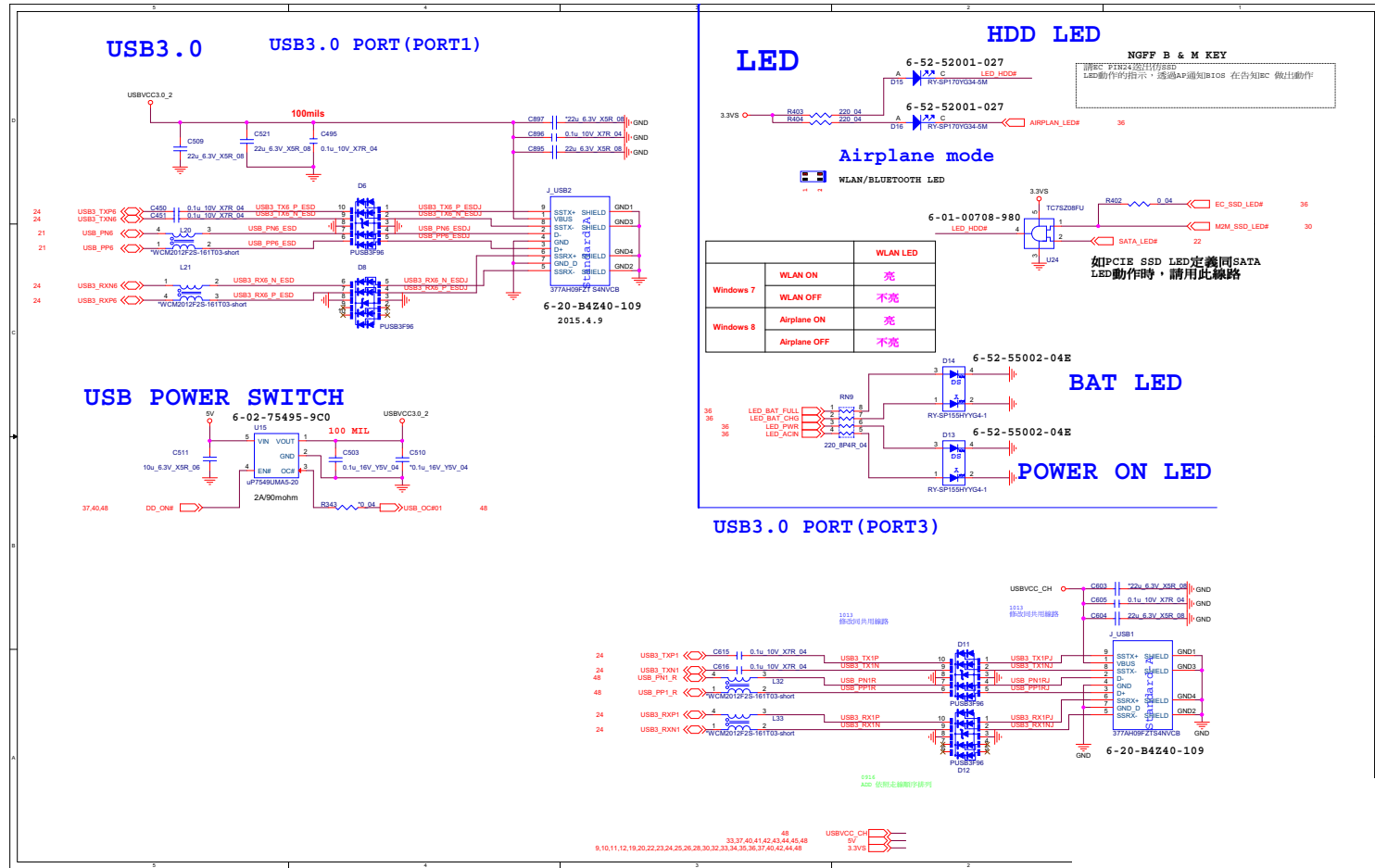

Sheet 31 of 51
USB3.0, LED

Card Reader (RTL8411B)

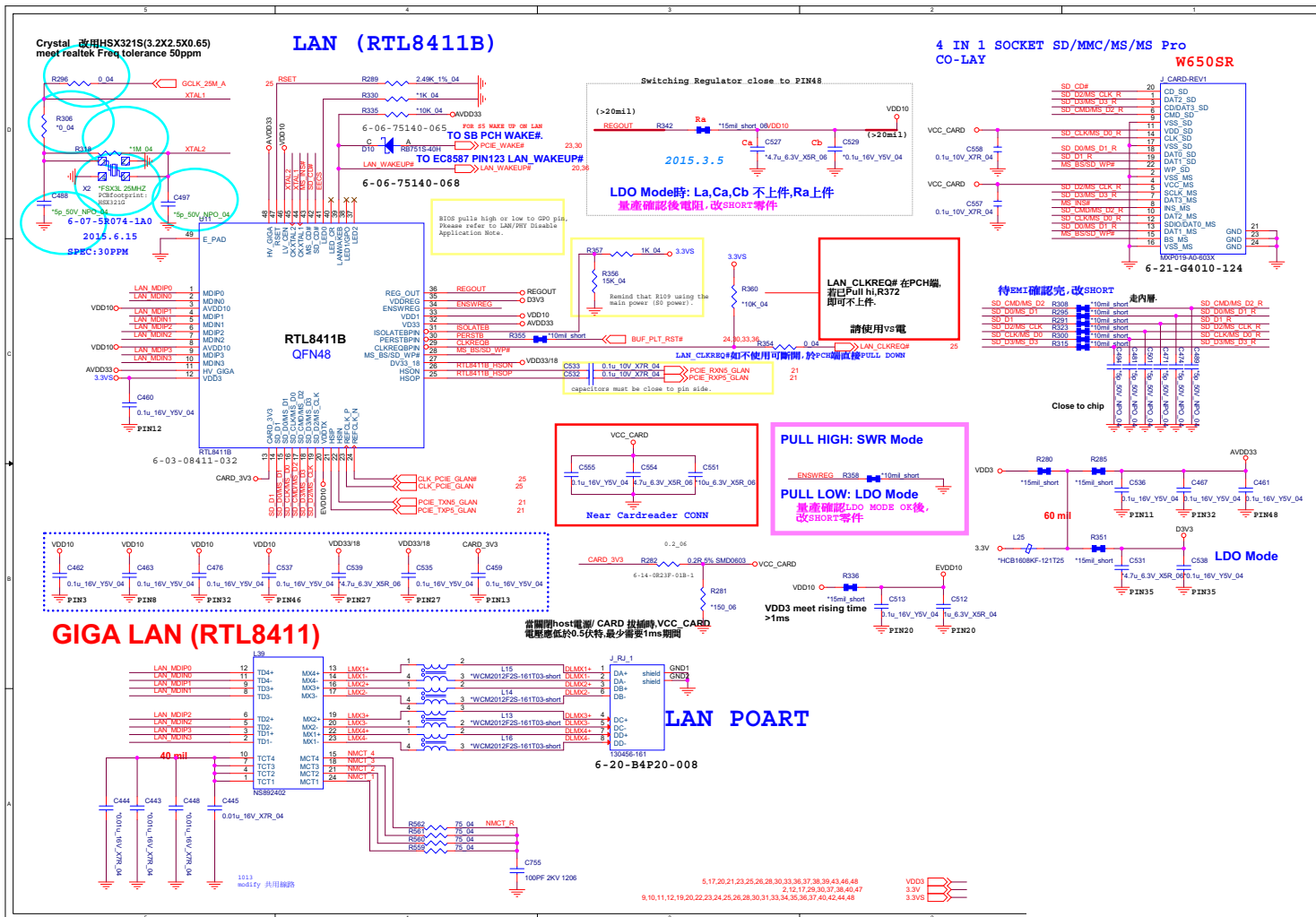

Sheet 32 of 51
Card Reader
(RTL8411B)

B.Schematic Diagrams

Schematic Diagrams

HDD, TP, Audio, USB

Sheet 33 of 51
HDD, TP, Audio,
USB

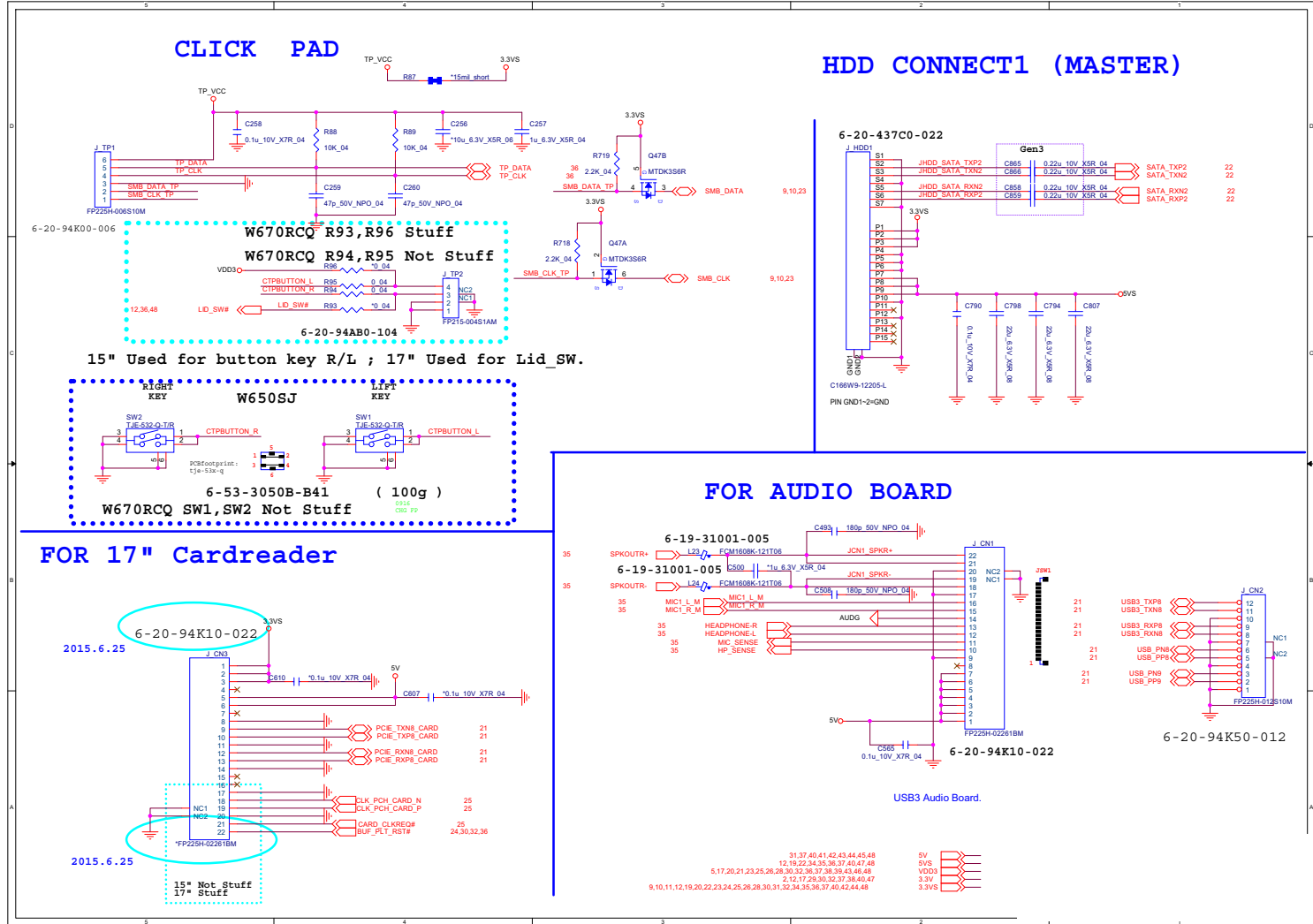

HDMI

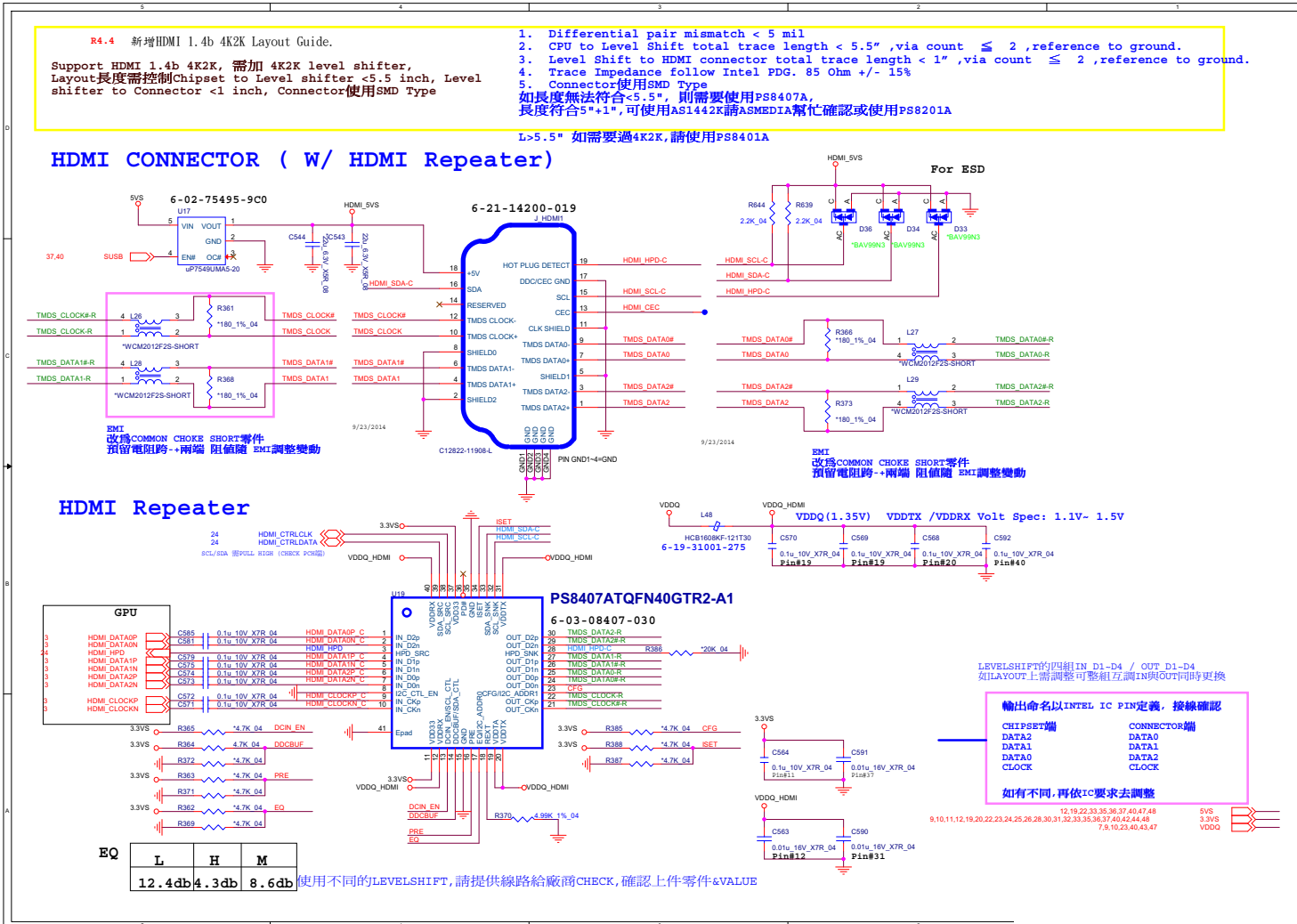

Sheet 34 of 51
HDMI

B.Schematic Diagrams

Schematic Diagrams

AUDIO CODEC ALC269 VC2

B. Schematic Diagrams

Sheet 35 of 51
AUDIO CODEC
ALC269 VC2

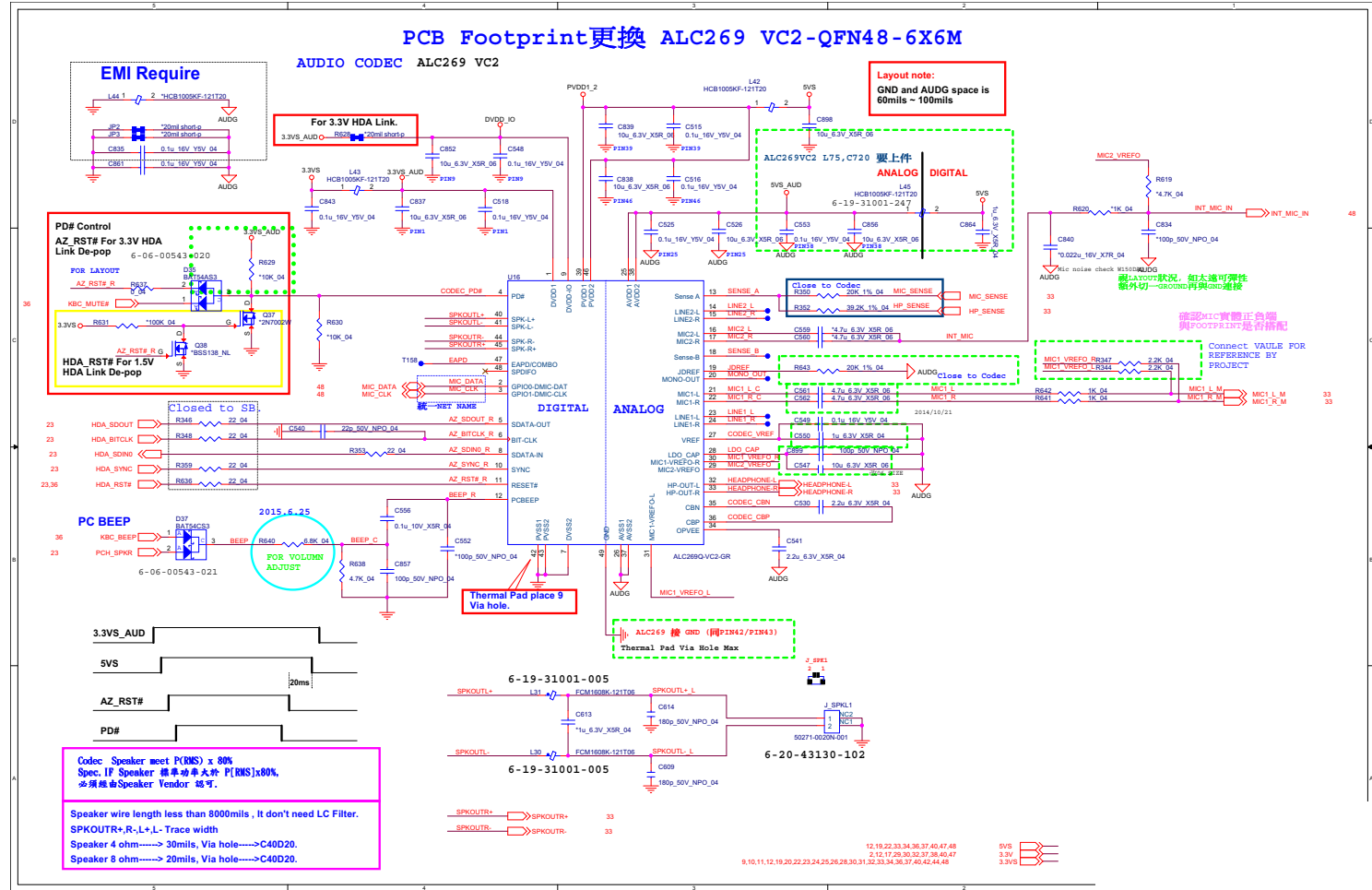

KBC-ITE IT8587

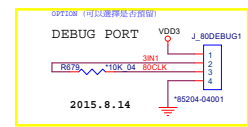
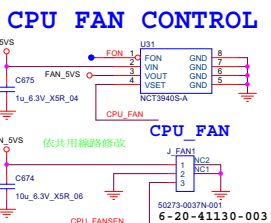
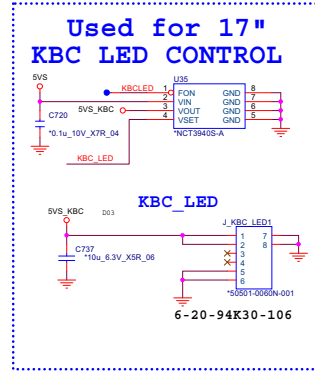
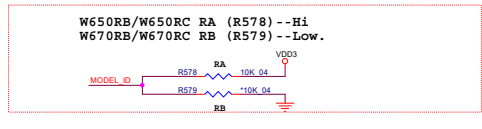
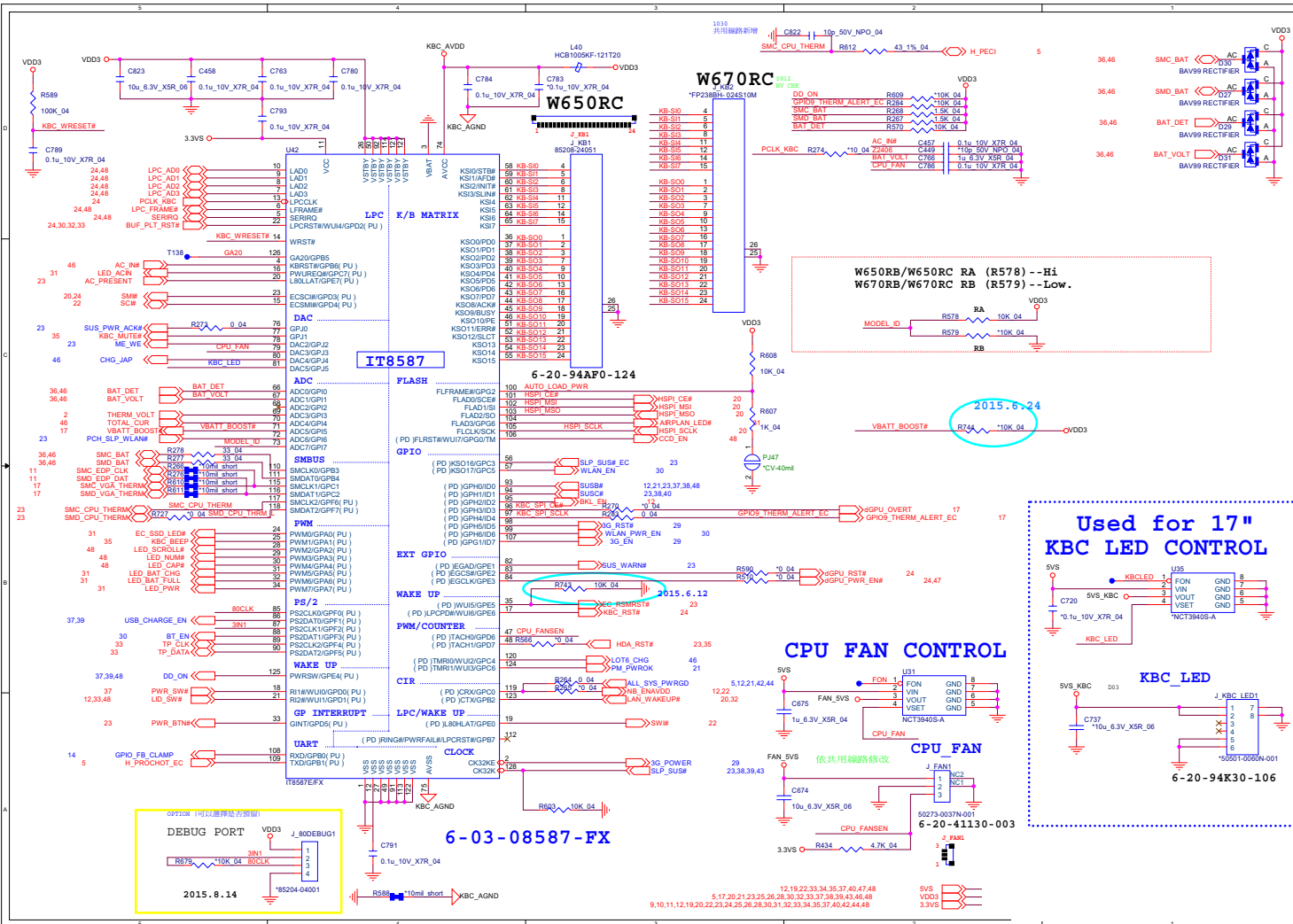

Sheet 36 of 51
KBC-ITE IT8587

B.Schematic Diagrams

Schematic Diagrams

5V, 5VS, 3.3V, 3.3VS, 3.3VA

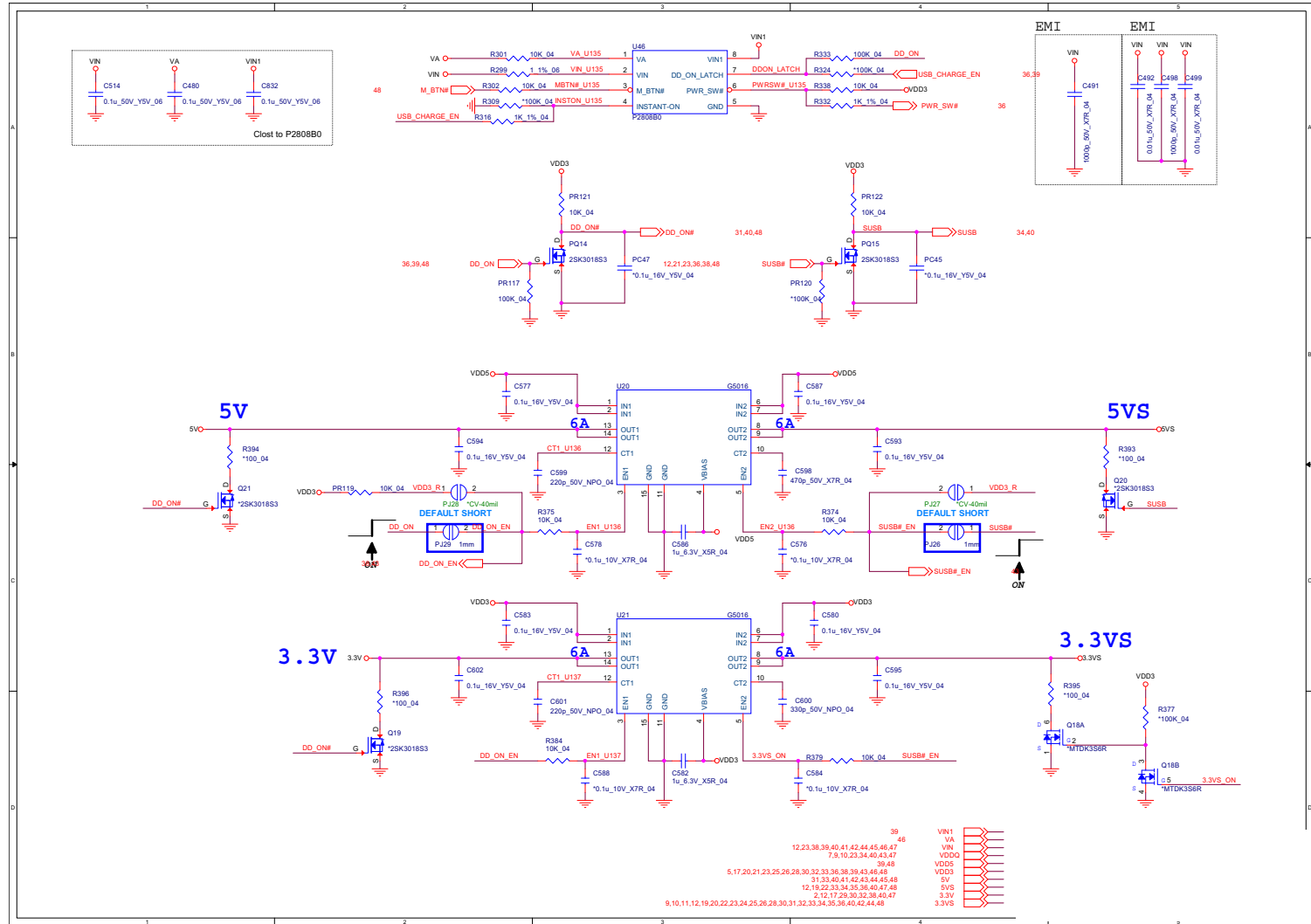

Sheet 37 of 51
5V, 5VS, 3.3V,
3.3VS, 3.3VA

B.Schematic Diagrams

1.0V, VCCIO

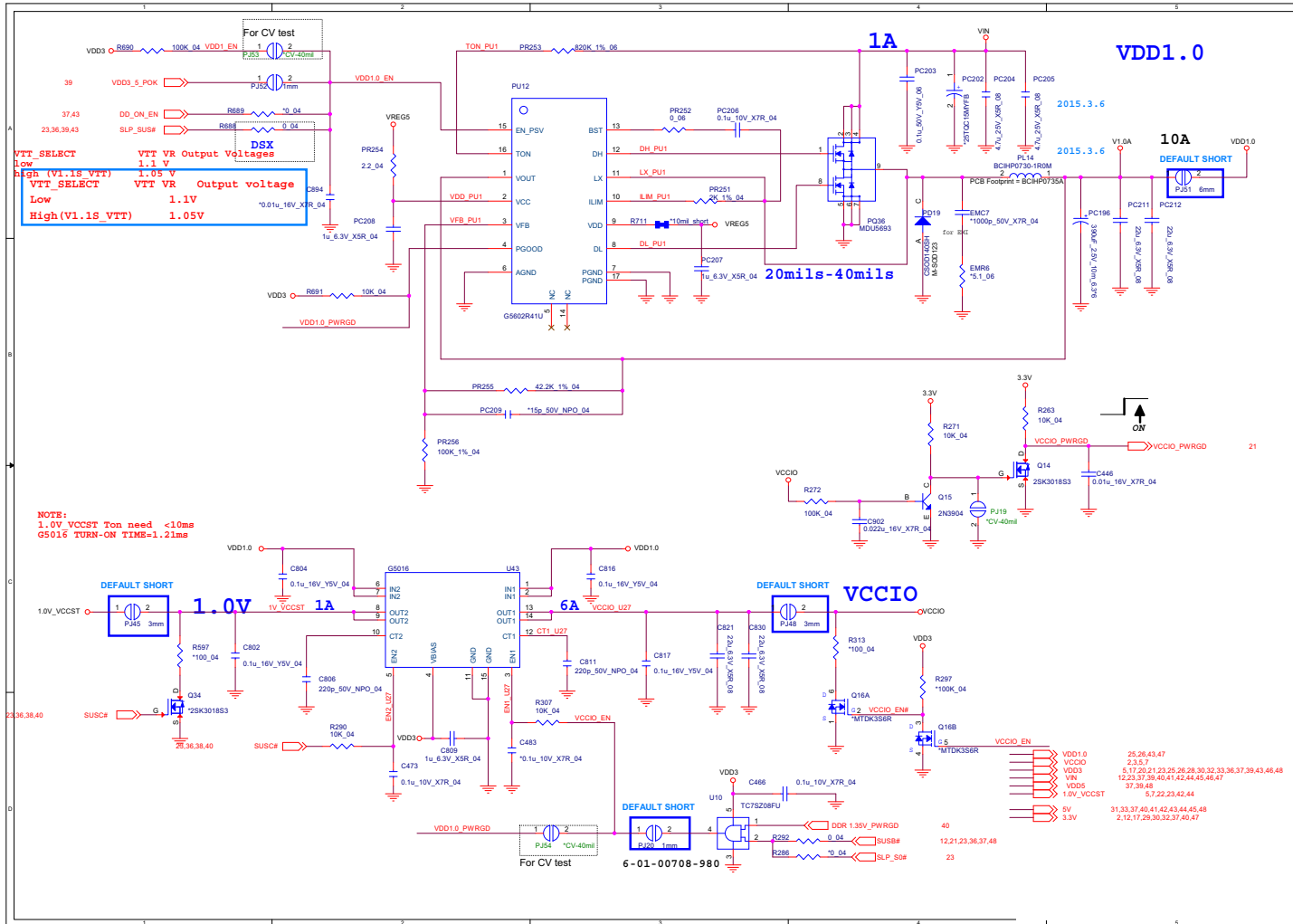

Sheet 38 of 51
1.0V, VCCIO

VDD3, VDD5

Sheet 39 of 51
VDD3, VDD5

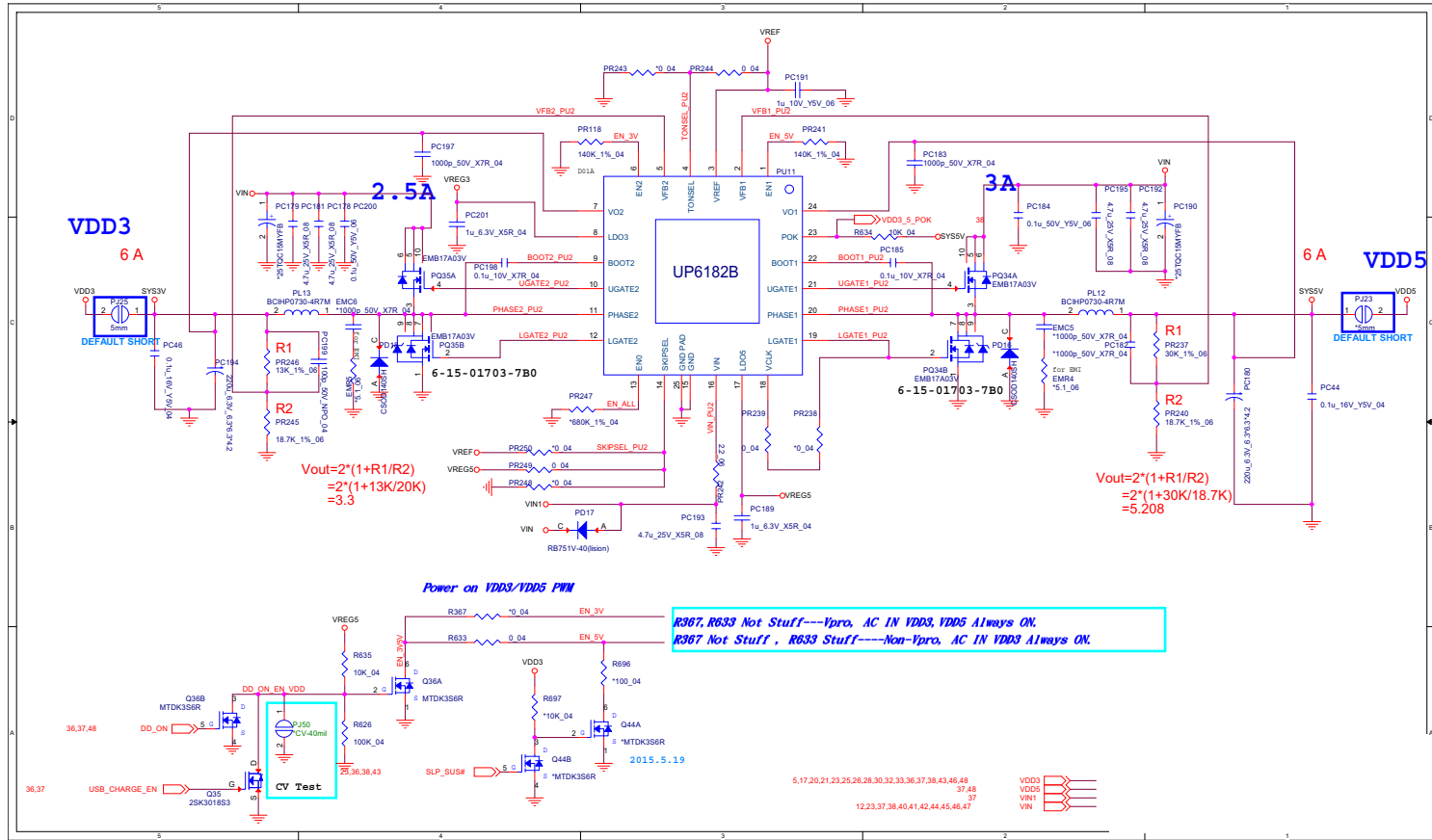

DDR3L 1.35V / 0.75VS

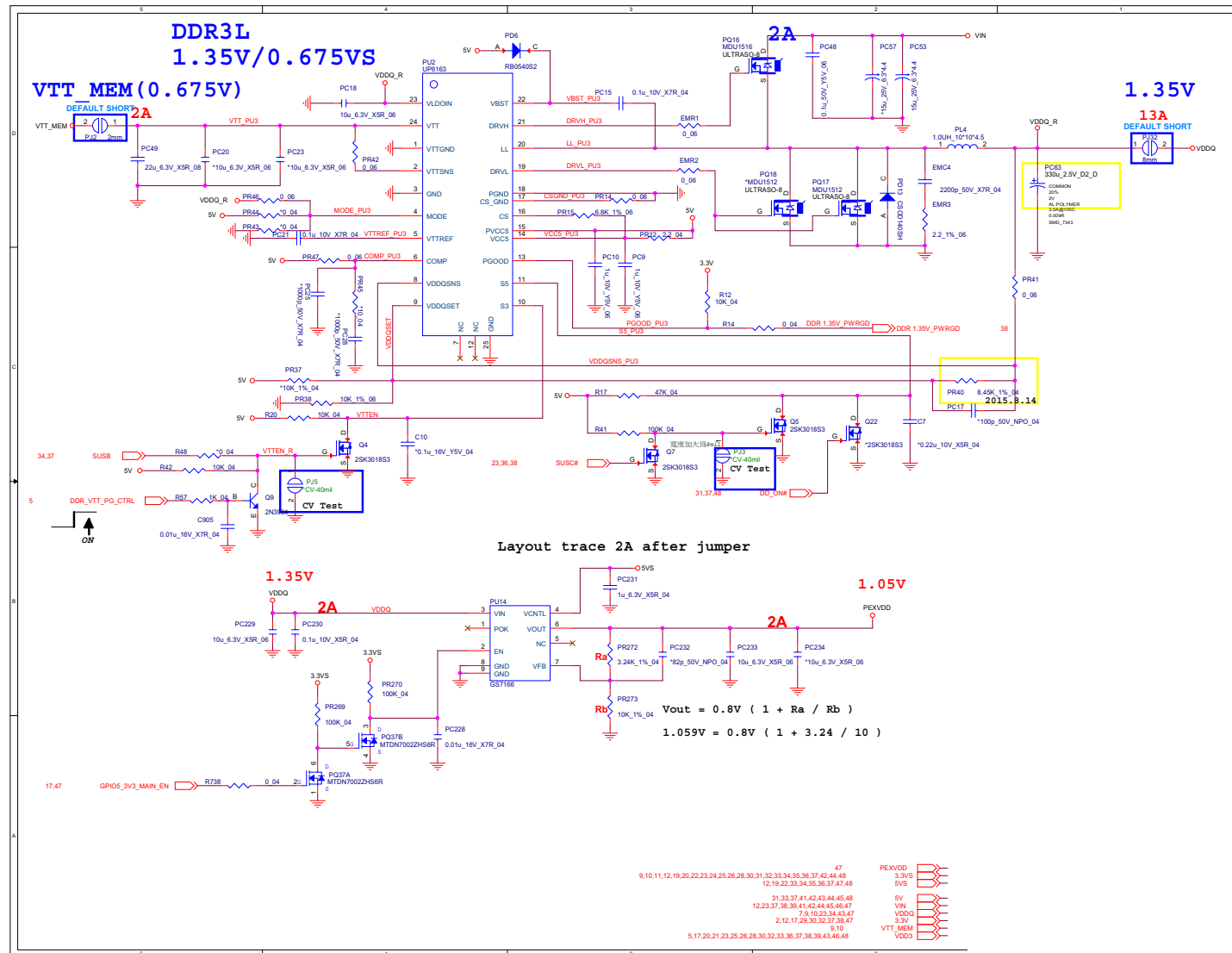

Sheet 40 of 51
DDR3L 1.35V /
0.75VS

B.Schematic Diagrams

Schematic Diagrams

POWER VCORE

Sheet 41 of 51
POWER VCORE

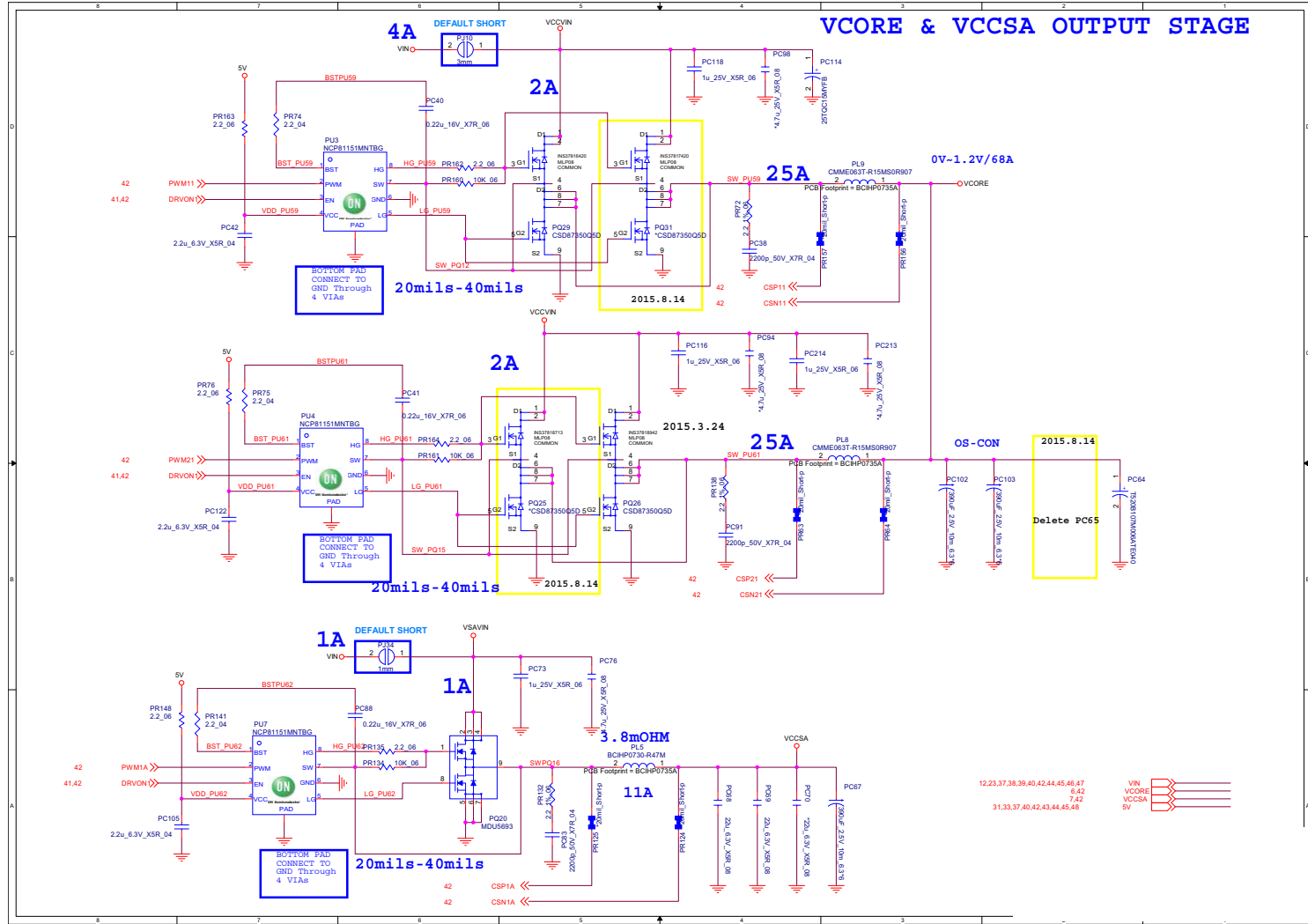

VCC_Core & VCCSA

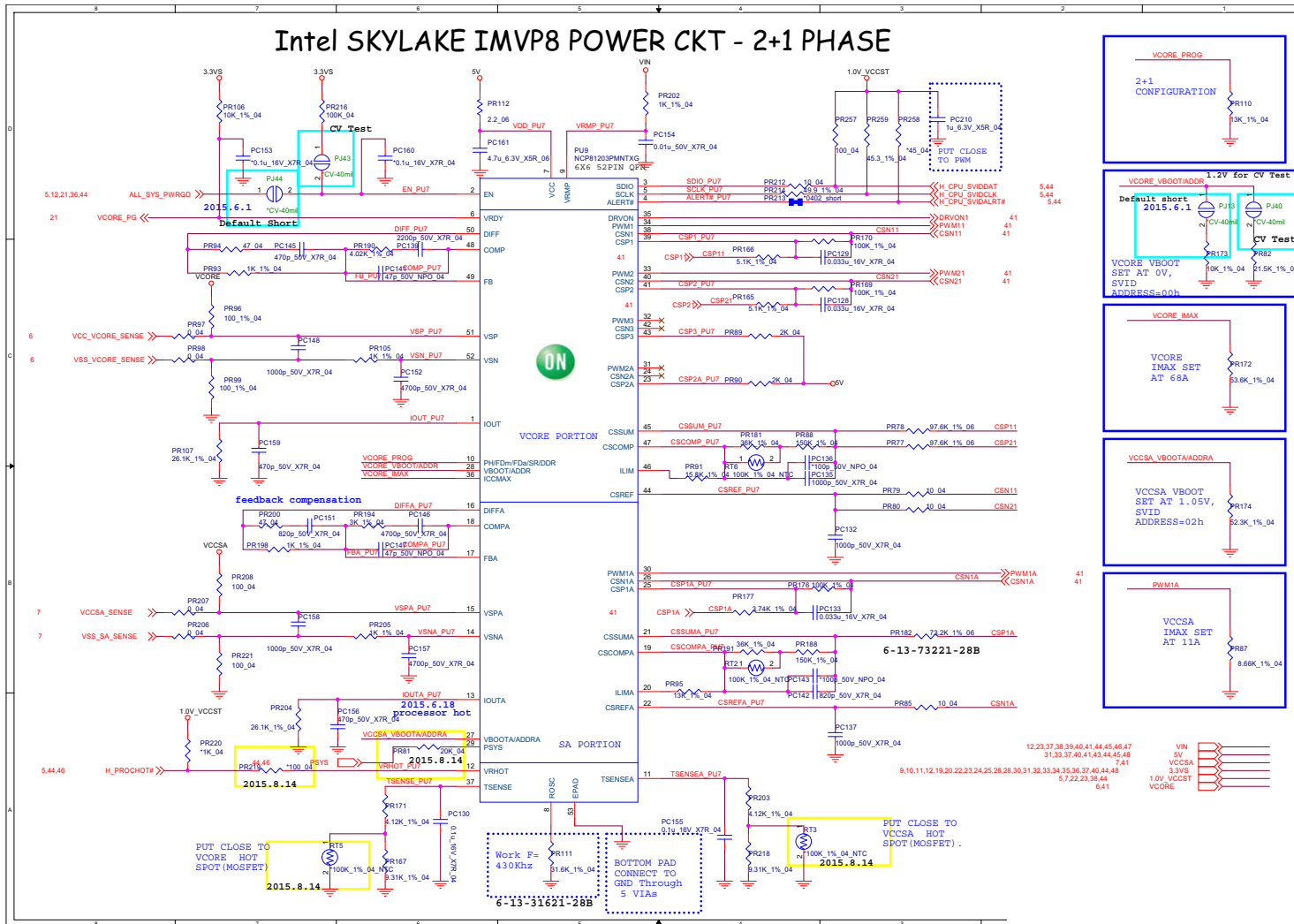

Sheet 42 of 51
VCC_Core &
VCCSA

B.Schematic Diagrams

Schematic Diagrams

1.0DX_VCCSTG / VCCSFR_OC

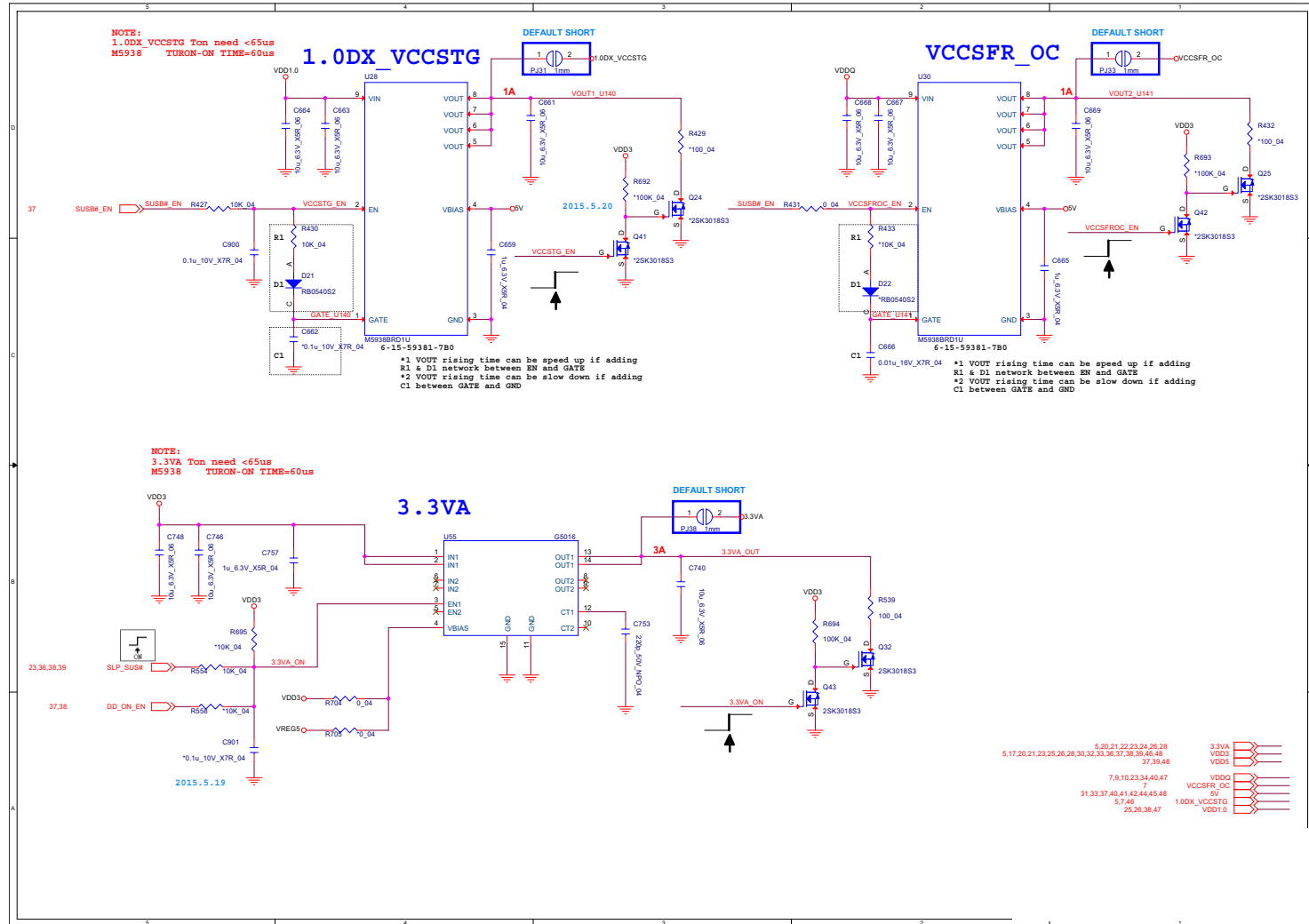

B.Schematic Diagrams

Sheet 43 of 51
1.0DX_VCCSTG /
VCCSFR_OC

VCCGT

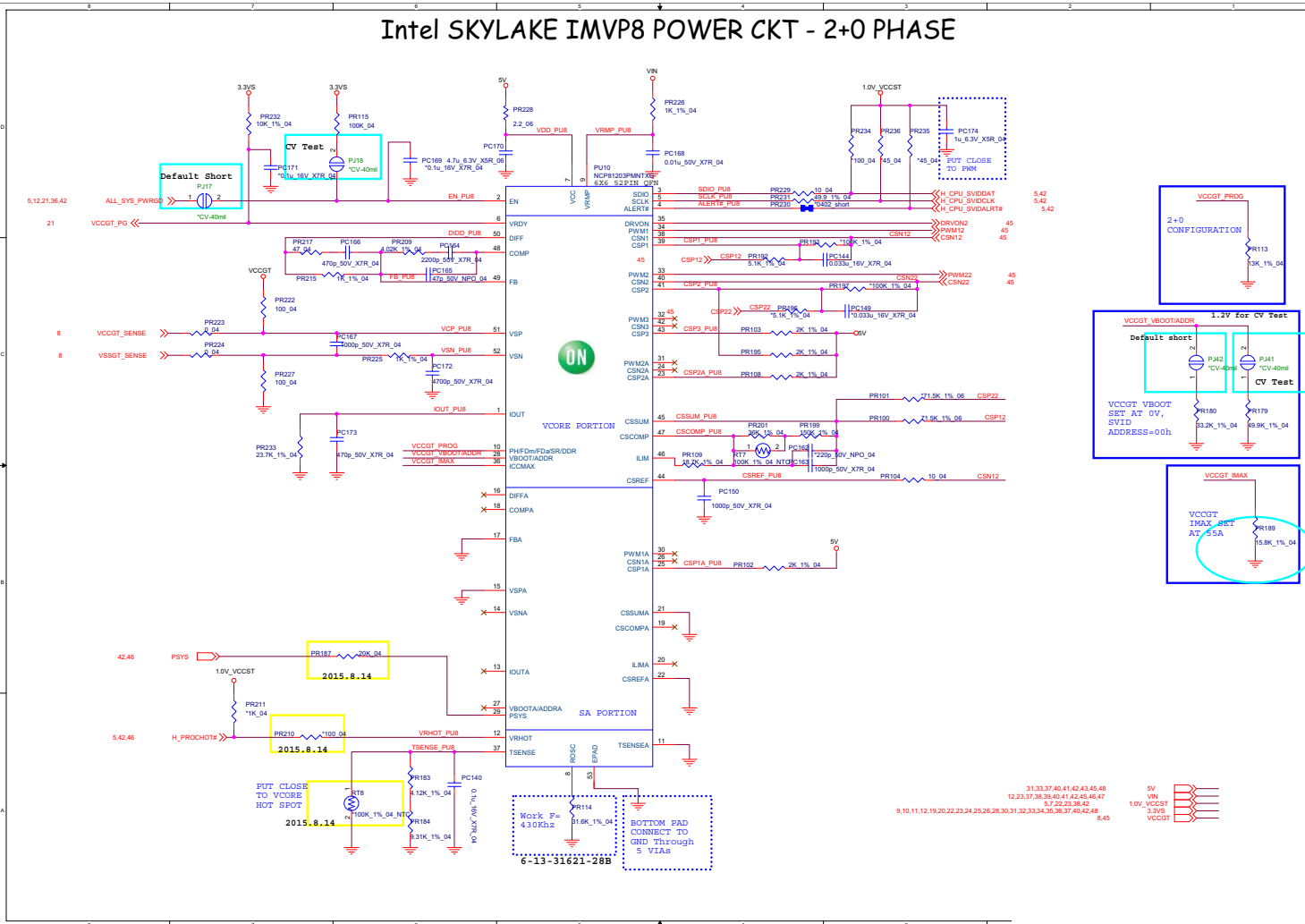

Sheet 44 of 51
VCCGT

B. Schematic Diagrams

VCCGT Output Stage

Sheet 45 of 51
VCCGT Output Stage

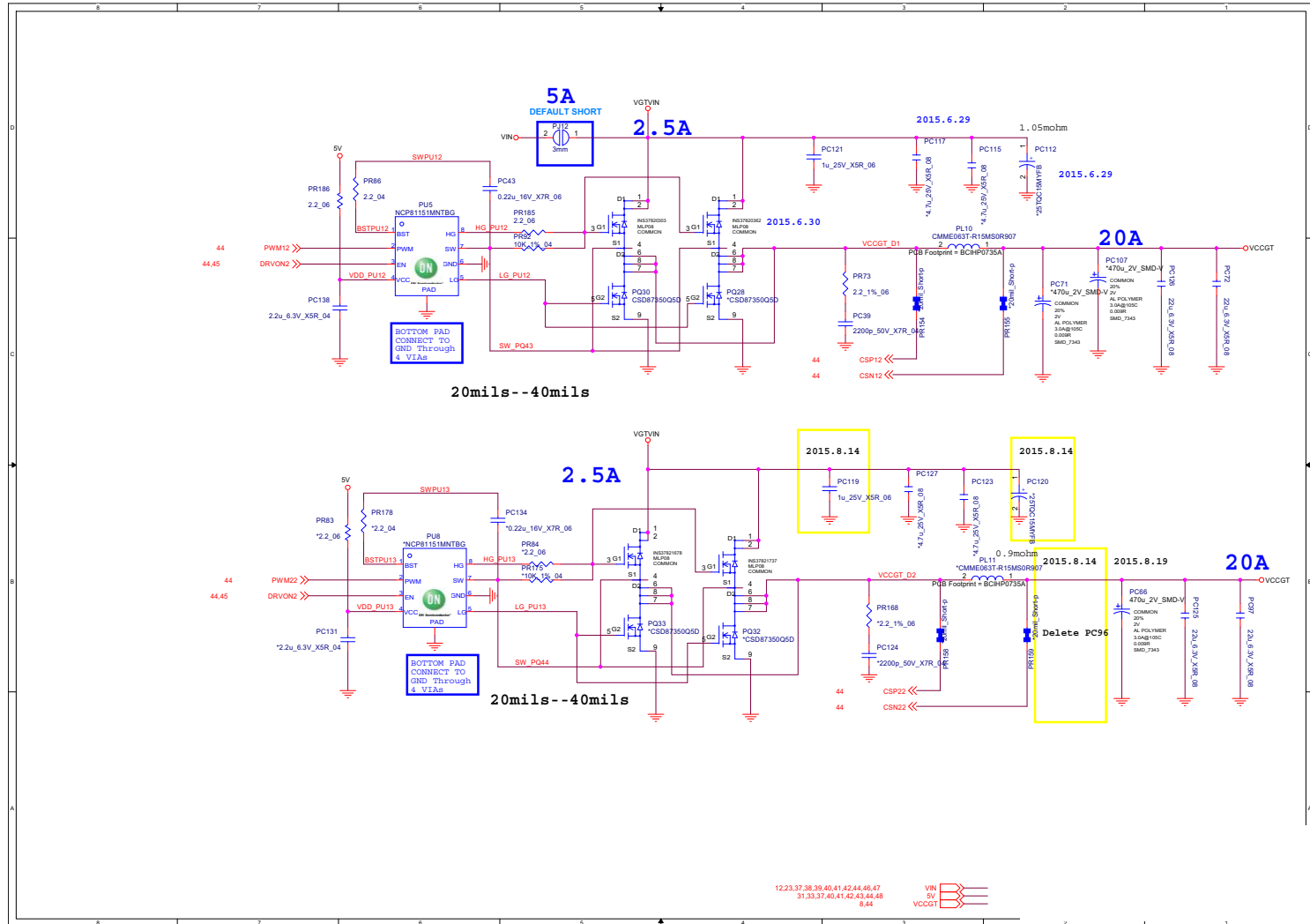

AC_In, Charger

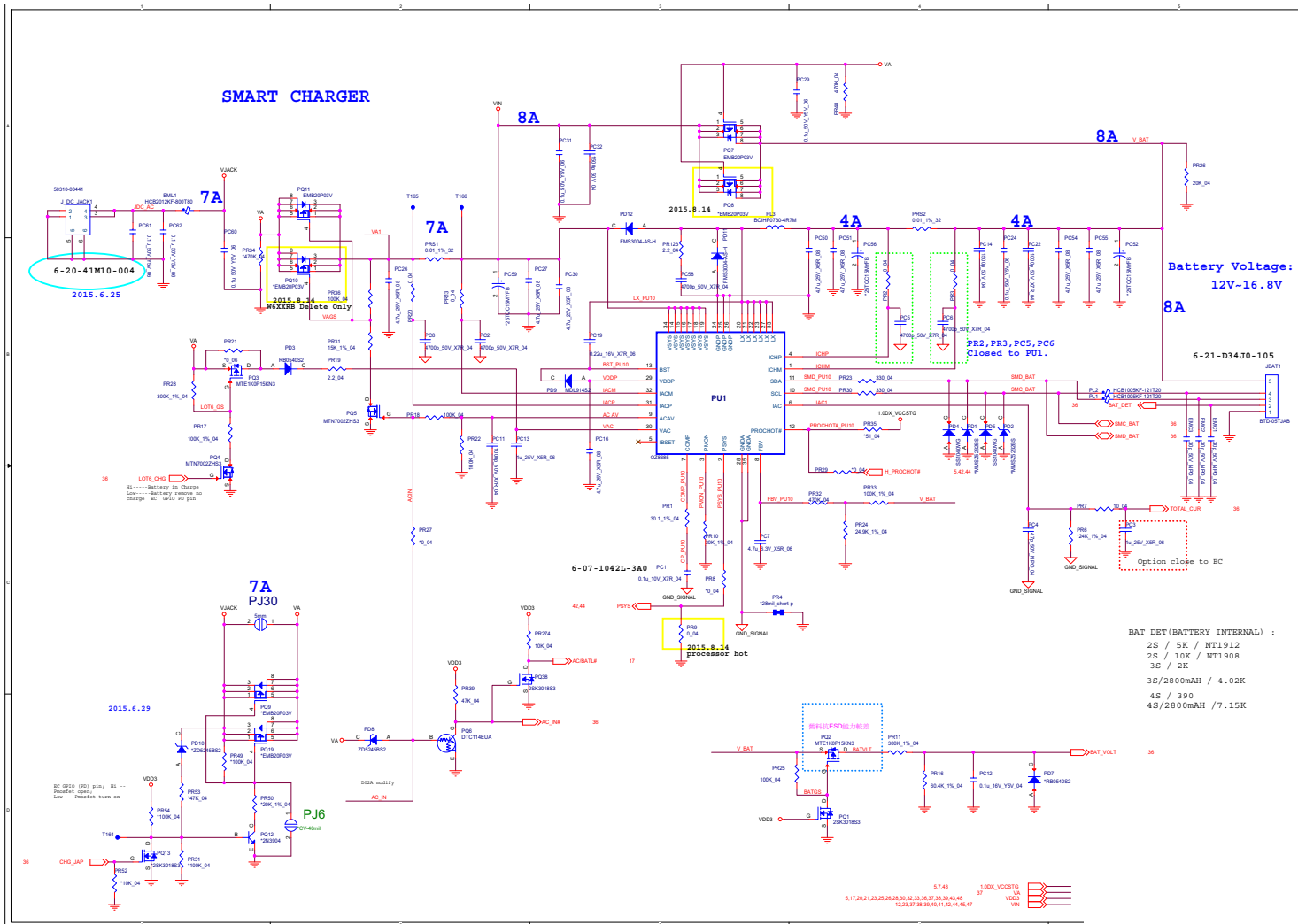

B.Schematic Diagrams

Sheet 46 of 51
AC_In, Charger

N16P/S, NVVDD, PEX, FBVDDQ

Sheet 47 of 51
N16P/S, NVVDD,
PEX, FBVDDQ

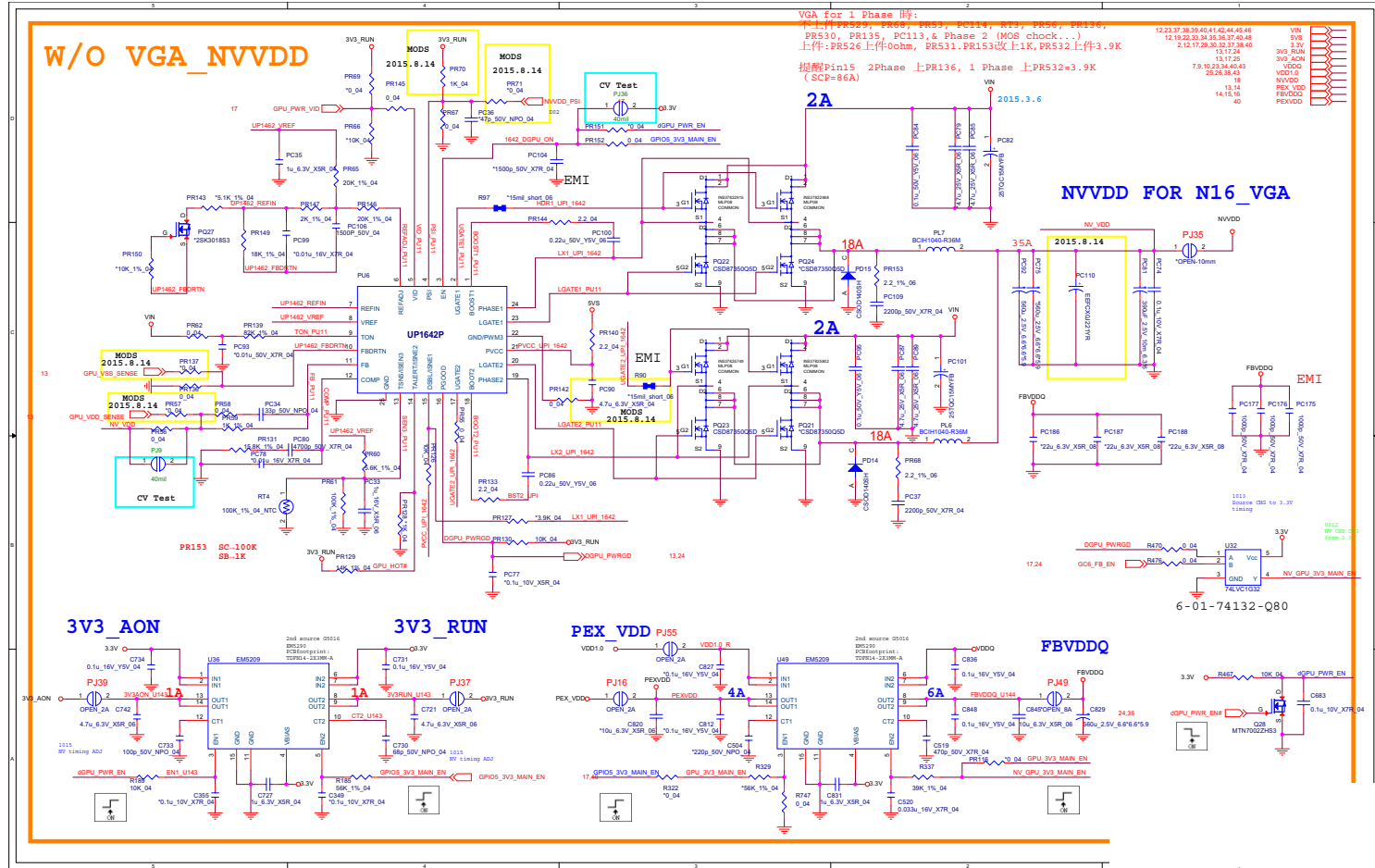

USB Charge, CCD, TPM, Power Conn

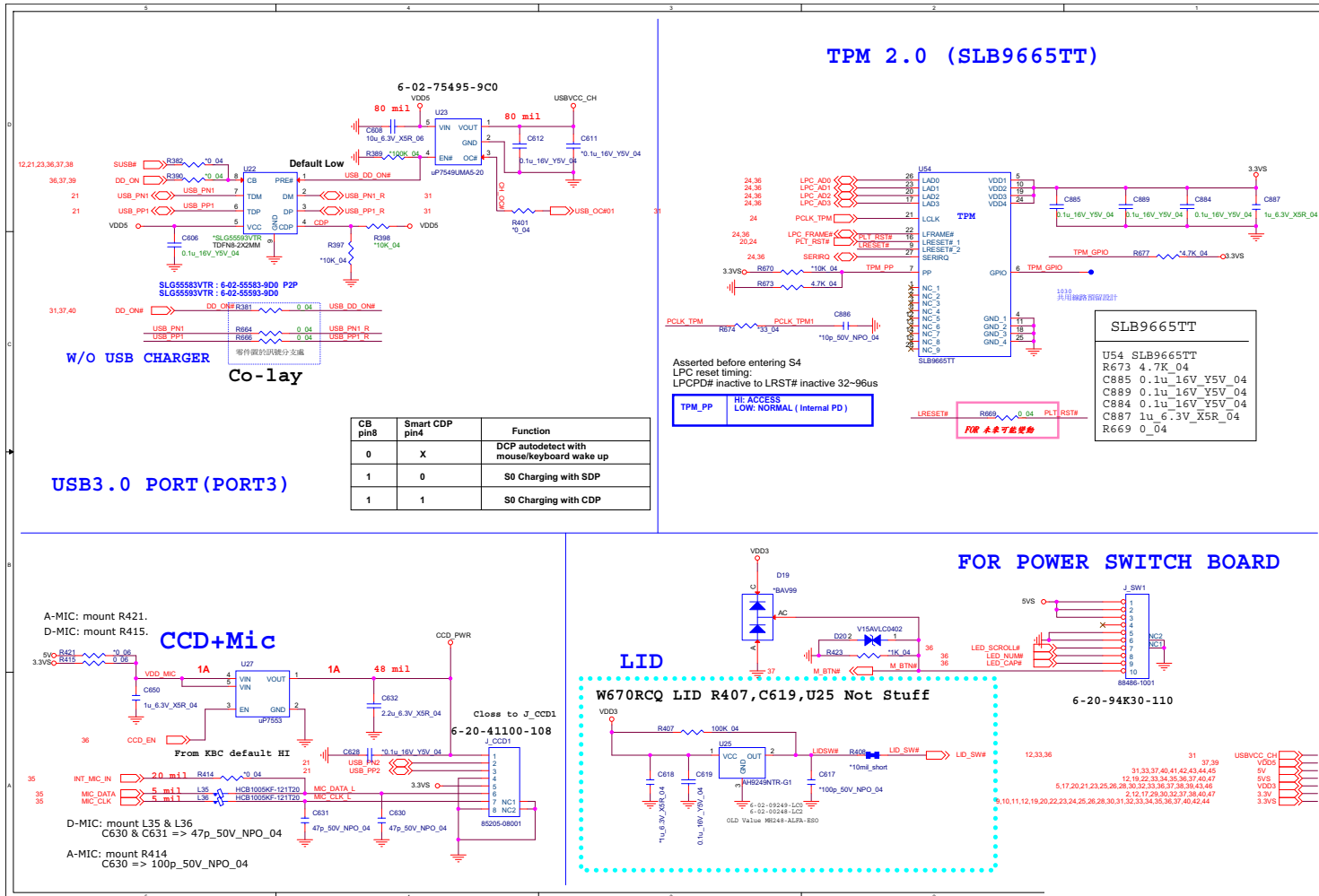

Sheet 48 of 51
USB Charge, CCD,
TPM, Power Conn

Audio Board

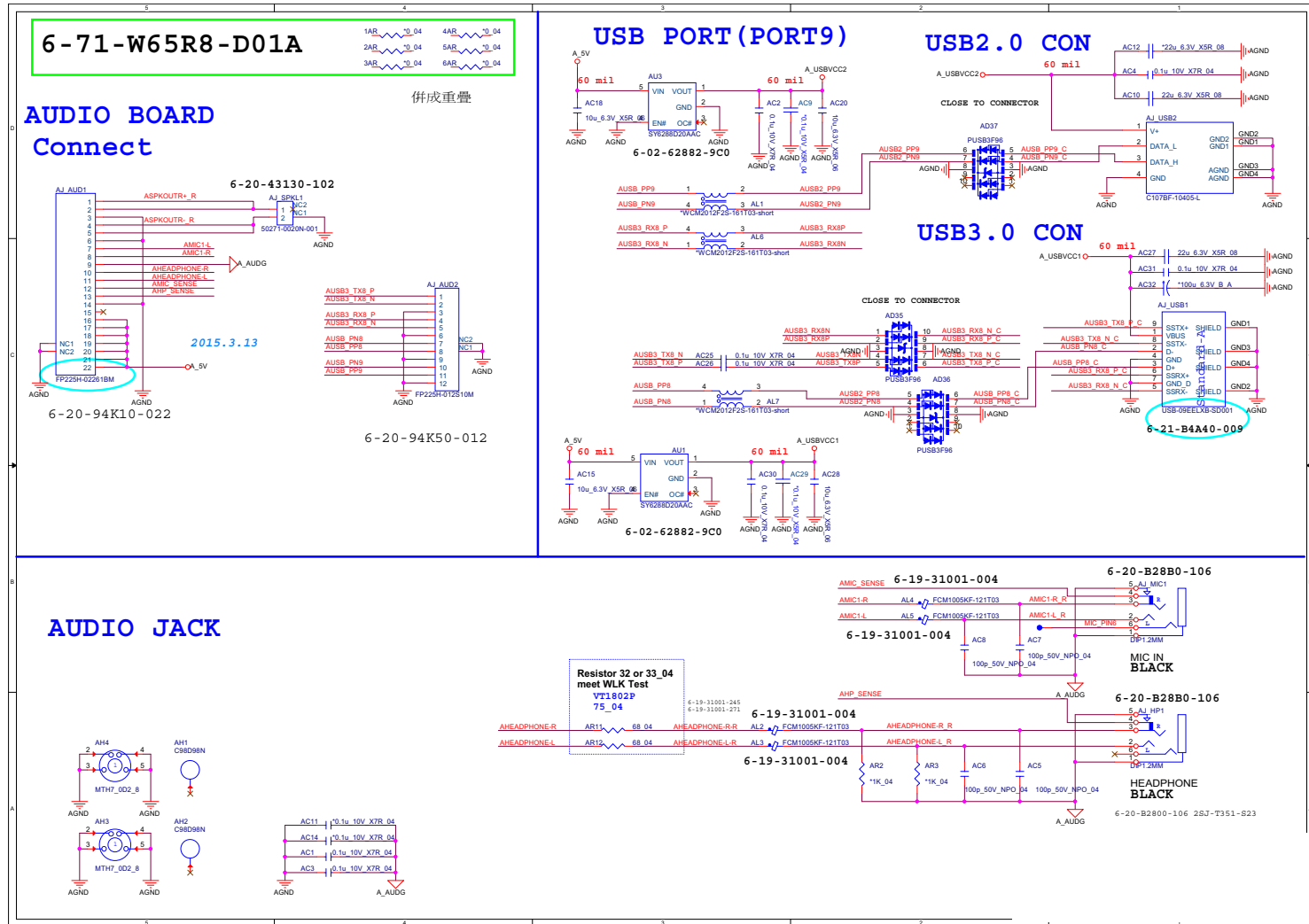

Sheet 49 of 51
 Audio Board

Power Switch Board

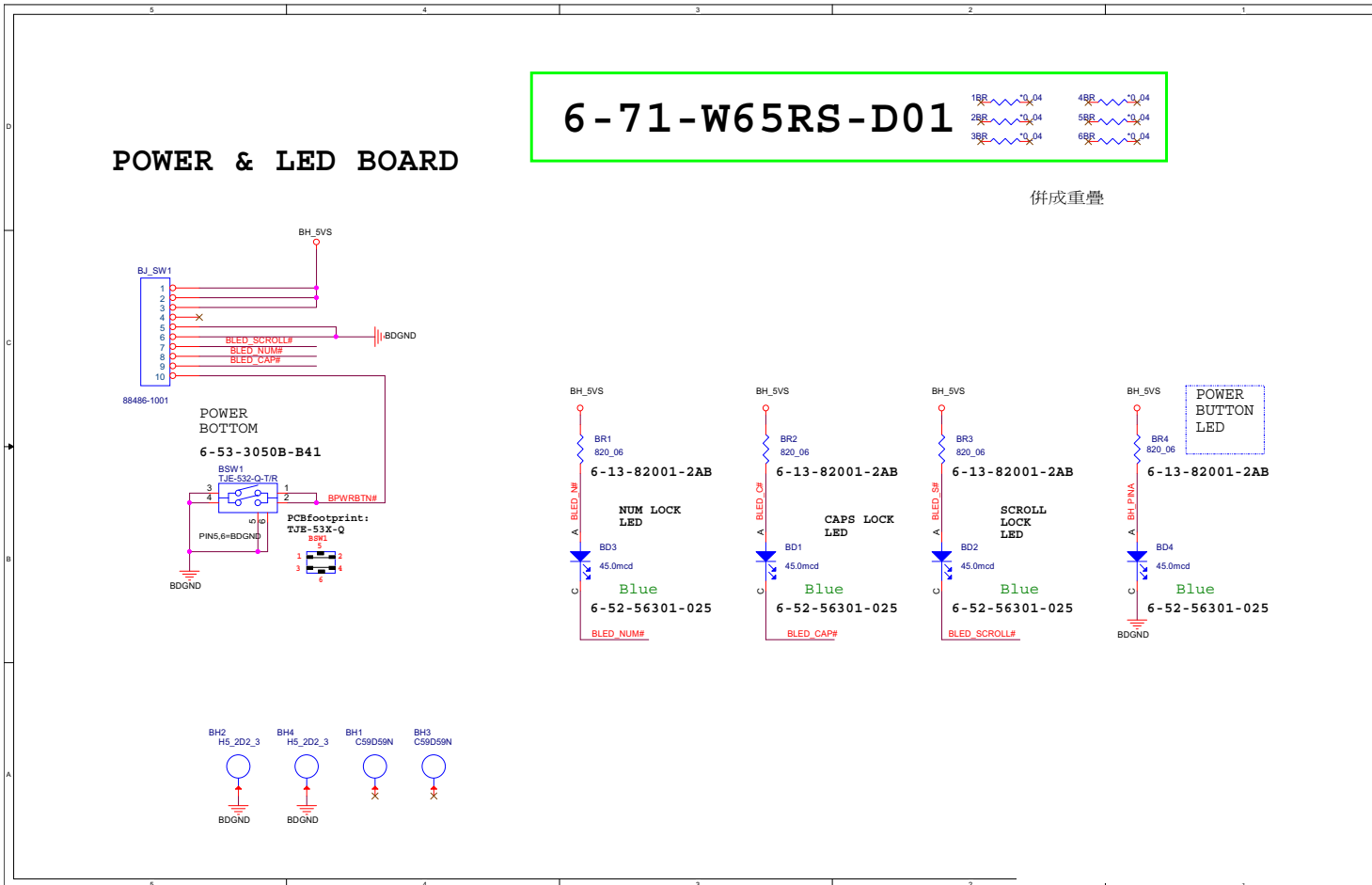

Sheet 50 of 51
Power Switch
Board

ODD to HDD Board

6-71-W650N-D04

1DR ~_0_04
2DR ~_0_04
3DR ~_0_04
4DR ~_0_04
5DR ~_0_04
6DR ~_0_04

M: 6-21-14030-013
S: 6-21-14020-013

ODD TO HDD BOARD

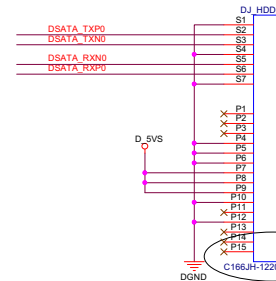
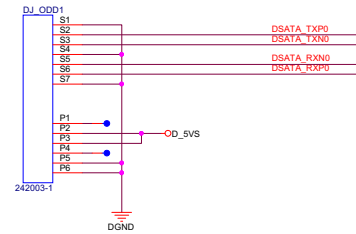

M: 6-21-43720-022

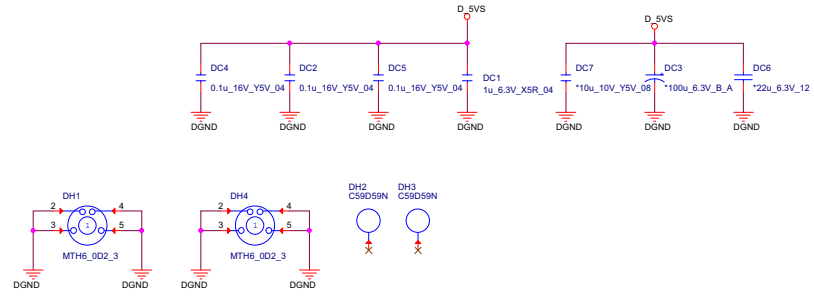

Sheet 51 of 51
ODD to HDD Board

Appendix C: Updating the FLASH ROM BIOS

To update the FLASH ROM BIOS, you must:

- Download the BIOS update from the web site.
- Unzip the files onto a bootable CD/DVD/USB Flash Drive.
- Reboot your computer from an external CD/DVD/USB Flash Drive.
- Use the flash tools to update the flash BIOS using the commands indicated below.
- Restart the computer booting from the HDD and press **F2** at startup enter the BIOS.
- Load setup defaults from the BIOS and save the default settings and exit the BIOS to restart the computer.
- After rebooting the computer you may restart the computer again and make any required changes to the default BIOS settings.

Download the BIOS

1. Go to www.clevo.com.tw and point to **E-Services** and click **E-Channel**.
2. Use your user ID and password to access the appropriate download area (BIOS), and download the latest BIOS files (the BIOS file will be contained in a batch file that may be run directly once unzipped) for your computer model (see sidebar for important information on BIOS versions).

Unzip the downloaded files to a bootable CD/DVD/ or USB Flash drive

1. Insert a bootable CD/DVD/USB flash drive into the CD/DVD drive/USB port of the computer containing the downloaded files.
2. Use a tool such as Winzip or Winrar to unzip all the BIOS files and refresh tools to your bootable CD/DVD/USB flash drive (you may need to create a bootable CD/DVD with the files using a 3rd party software).

Set the computer to boot from the external drive

1. With the bootable CD/DVD/USB flash drive containing the BIOS files in your CD/DVD drive/USB port, restart the computer and press **F2** (in most cases) to enter the BIOS.
2. Use the arrow keys to highlight the **Boot** menu.
3. Use the “+” and “-” keys to move boot devices up and down the priority order.
4. Make sure that the CD/DVD drive/USB flash drive is set first in the boot priority of the BIOS.
5. Press **F4** to save any changes you have made and exit the BIOS to restart the computer.



BIOS Version

Make sure you download the latest correct version of the BIOS appropriate for the computer model you are working on.

You should only download BIOS versions that are **V1.00.XX or higher** as appropriate for your computer model.

Note that BIOS versions are not backward compatible and therefore **you may not downgrade your BIOS to an older version** after upgrading to a later version (e.g if you upgrade a BIOS to ver 1.00.05, you **MAY NOT** then go back and flash the BIOS to ver 1.00.04).

BIOS Update

Use the flash tools to update the BIOS

1. Make sure you are not loading any memory management programs such as HIMEM by holding the **F8** key as you see the message “**Starting MS-DOS**”. You will then be prompted to give “**Y**” or “**N**” responses to the programs being loaded by DOS. Choose “**N**” for any memory management programs.
2. You should now be at the DOS prompt e.g: DISK C:\> (C is the designated drive letter for the CD/DVD drive/USB flash drive).
3. **Type the following command** at the DOS prompt:

C:\> Flash.bat

4. The utility will then proceed to flash the BIOS.
5. You should then be prompted to press any key to restart the system or turn the power off, and then on again but make sure you remove the CD/DVD/USB flash drive from the CD/DVD drive/USB port before the computer restarts.

Restart the computer (booting from the HDD)

1. With the CD/DVD/USB flash drive removed from the CD/DVD drive/USB port the computer should restart from the HDD.
2. Press **F2** as the computer restarts to enter the BIOS.
3. Use the arrow keys to highlight the **Exit** menu.
4. Select **Load Setup Defaults** (or press **F3**) and select “**Yes**” to confirm the selection.
5. Press **F4** to save any changes you have made and exit the BIOS to restart the computer.

Your computer is now running normally with the updated BIOS

You may now enter the BIOS and make any changes you require to the default settings.